

single cylinder engine

SERVICE MANUAL

MAGNUM

MODELS M8, M10, M12, M14, M16

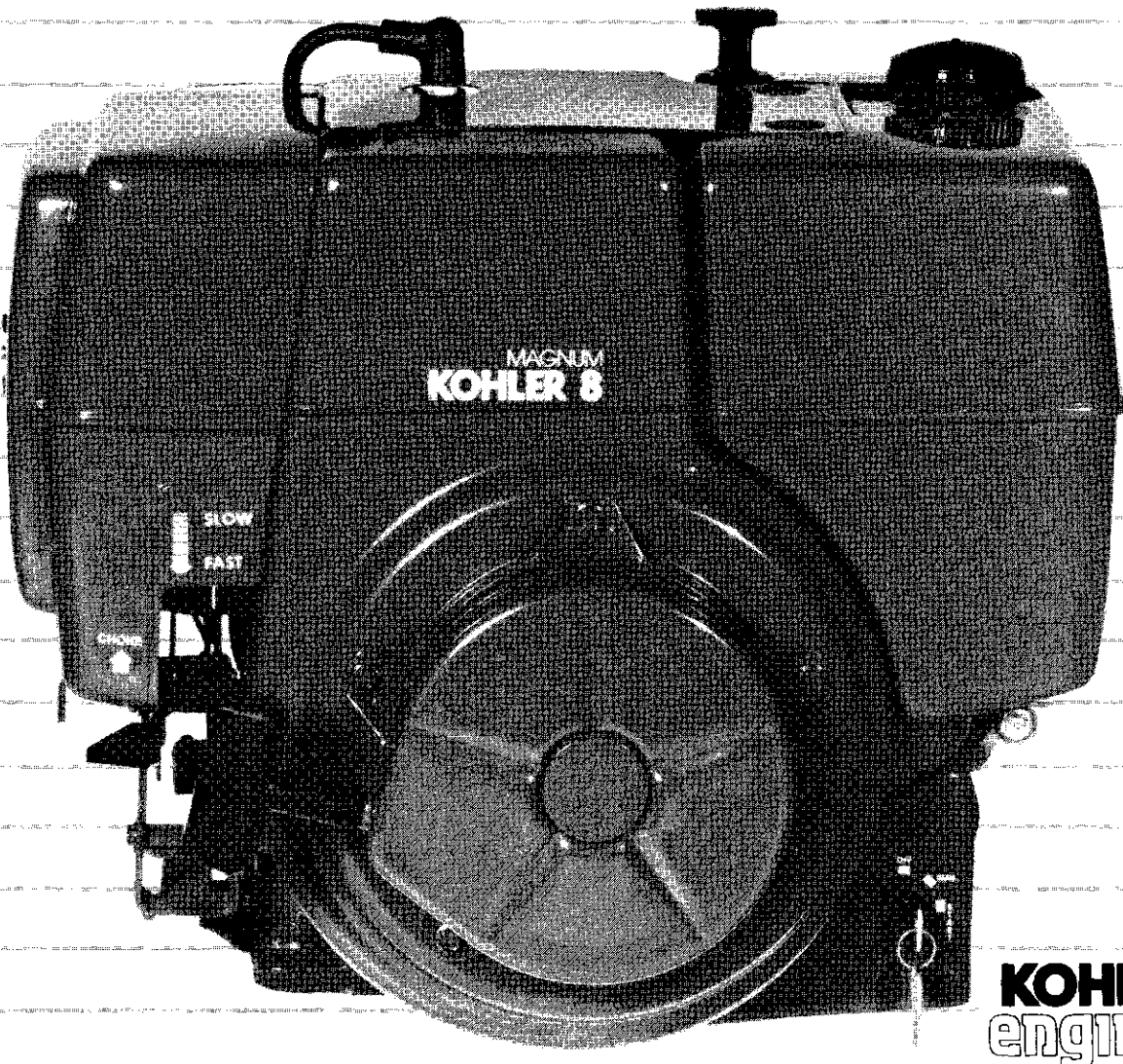

CONTENTS

SECTION 1. General Information	1
SECTION 2. Special Tools	2
SECTION 3. Periodic Maintenance	3
SECTION 4. Troubleshooting	4
SECTION 5. Air Cleaner	5
SECTION 6A. Fuel System And Governor	6
SECTION 7. Retractable Starters	7
SECTION 8. Electrical System And Components	8
SECTION 9. Automatic Compression Release	9
SECTION 10A. Disassembly—Model M8 10B. Disassembly—Models M10, M12, M14, And M16	10
SECTION 11. Inspection And Repair/Reconditioning	11
SECTION 12A. Reassembly—Model M8 12B. Reassembly—Models M10, M12, M14, And M16	12

MAGNUM

Single Cylinder Engine
Service Manual

Models M8, M10, M12
M14, M16

TP-2203-A 3/86



GENERAL INFORMATION

ENGINE IDENTIFICATION NUMBERS

When ordering parts, or in any communication involving an engine, always give the model, specification, and serial numbers of the engine.

The engine identification numbers appear on a decal (or decals) affixed to the engine blower housing. Refer to Figure 1-1. The significance of these numbers is shown below:

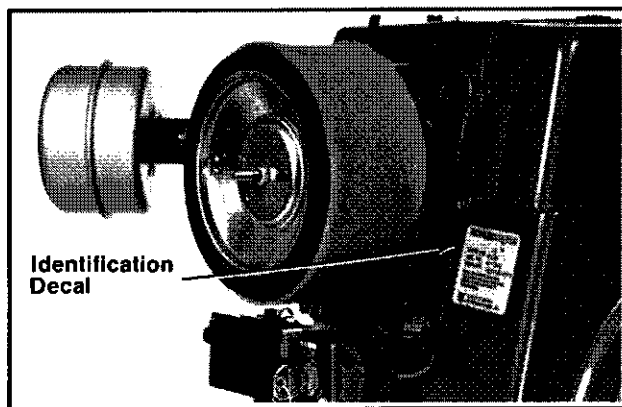

Figure 1-1. Location Of Engine Identification Decal.

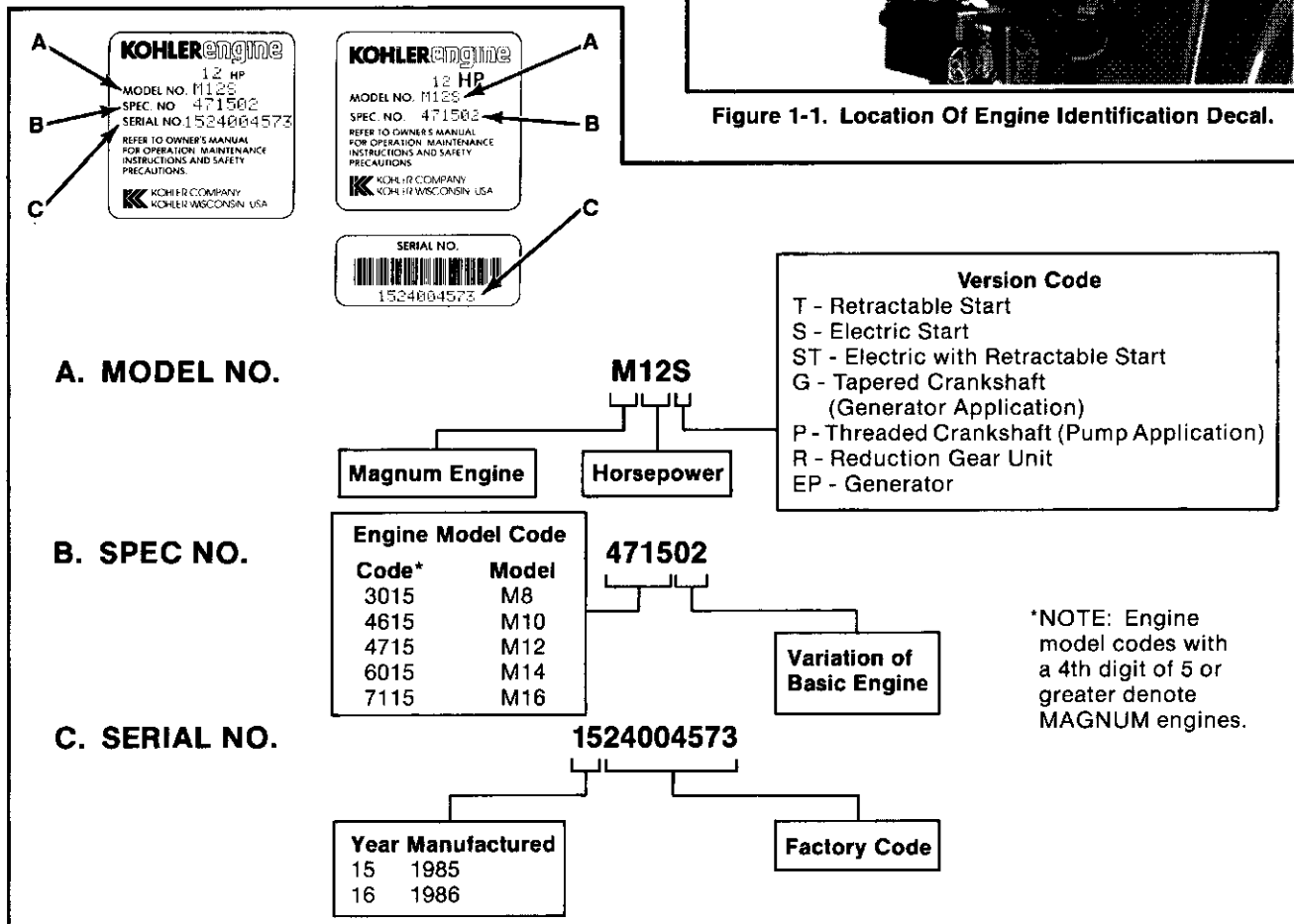

Figure 1-2. Engine Identification Decals.

SAFETY INFORMATION

For Your Safety!

These precautions should be followed at all times. Failure to follow these precautions could result in injury to yourself and others.



Accidental Starts!

Before servicing the engine or equipment, always disconnect the spark plug lead to prevent the engine from starting accidentally. Ground the lead to prevent sparks which could cause fires.

On engines equipped with 12 volt battery and/or electric start, disconnect the battery cables from battery. Always disconnect the negative (-) cable first.

Before disconnecting the negative (-) ground cable, make sure all switches are OFF. If ON, a spark will occur at the ground cable terminal which could cause an explosion if hydrogen gas or gasoline vapors are present.

⚠ CAUTION: High Voltage!
Never touch electrical wires or components while the engine is running. They can be sources of electrical shock which could cause severe injury or burns.

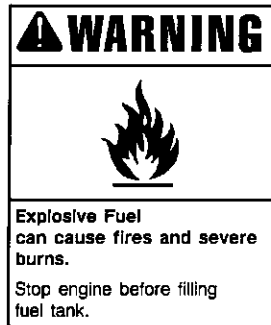

Explosive Fuel!

Gasoline is extremely flammable, and its vapors can explode if ignited. Store gasoline only in approved containers, in well-ventilated unoccupied buildings, away from sparks or flames. Do not fill fuel tank while the engine is hot or running since spilled fuel could ignite if it comes in contact with hot parts or sparks from ignition. Do not start the engine near spilled fuel; wipe up spills immediately. Never use gasoline as a cleaning agent.

⚠ WARNING: Lead-Acid Storage Battery!
Use extreme care when handling or charging the battery. Batteries contain sulfuric acid—avoid contact with skin, eyes, and clothing. Batteries produce explosive hydrogen gas while being charged. Charge batteries only in well-ventilated areas. Keep cigarettes, sparks, open flame, and other sources of ignition away at all times. Keep batteries and acid out of the reach of children.

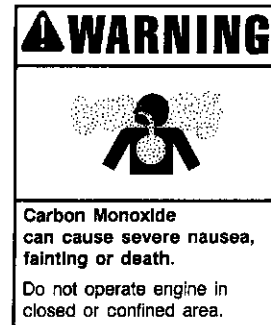

Lethal Exhaust Gases!

Engine exhaust gases contain poisonous carbon monoxide. Carbon monoxide is odorless, colorless, and can cause death if inhaled. Avoid inhaling exhaust fumes, and never run the engine in a closed building or confined area.

⚠ WARNING: Spring Under Tension!
Retractable starters contain a powerful, flat wire recoil spring that is under tension. Do not remove the center screw from starter until the spring tension is released. Removing the center screw before releasing spring tension, or improper starter disassembly, can cause the sudden and potentially dangerous release of the spring.

Always wear safety goggles when servicing retractable starters—full face protection is recommended.

To ensure personal safety and proper starter disassembly and reassembly, the procedures specified in the "Retractable Starters" section must be followed carefully.

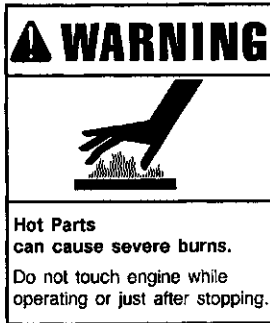

Hot Parts!

The crankcase, cylinder head, exhaust system, and other components get extremely hot from operation. To prevent severe burns, do not touch these areas while the engine is running – or immediately after it is turned off. Never operate the engine with heat shields or guards removed.

⚠ WARNING: Explosive Fuel!
Gasoline may be present in the intake manifold, carburetor, and fuel system. Gasoline is extremely flammable, and its vapors can explode if ignited. Keep cigarettes, sparks, open flames, and other sources of ignition away from the engine. Wipe up spilled fuel immediately.

⚠ WARNING: Flammable Solvents!
Carburetor cleaners and degreasing solvents are extremely flammable. Keep sparks, flames, and other sources of ignition away from area. Follow the cleaner manufacturer's warnings and instructions on its proper and safe use. Never use gasoline as a cleaning agent.

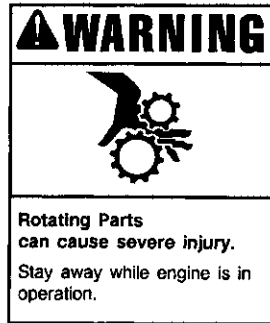

Rotating Parts!

Keep hands, feet, hair, and clothing away from all moving parts to prevent injury. Never operate the engine with covers, shrouds, or guards removed.

⚠ WARNING: Damaging Crankshaft and Flywheel Could Cause Personal Injury!
Using improper procedures to remove or install the flywheel can crack or damage the crankshaft and/or flywheel. This not only causes extensive engine damage, but also is a serious threat to the safety of persons nearby, since broken fragments could be thrown from the engine. Always observe and use the precautions, procedures, and tools specified in the "Disassembly" and "Reassembly" sections when removing or installing the flywheel.

⚠ WARNING: Old Spring Cannot Be Reinstalled!
Do not attempt to rewind or reinstall a spring once it has been removed from the spring retainer or starter housing. Severe personal injury could result from the sudden uncoiling of the spring. Always order and install a new spring which is held in a specially designed spring retainer.

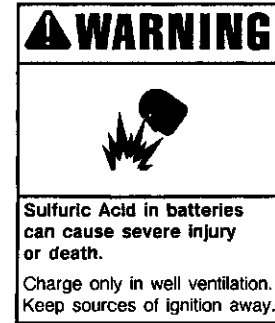

Dangerous Acid, Explosive Gases!

Batteries contain sulfuric acid. To prevent acid burns, avoid contact with skin, eyes, and clothing. Batteries produce explosive hydrogen gas while being charged. To prevent a fire or explosion, charge the battery only in well-ventilated areas. Keep sparks, open flame, and other sources of ignition away from battery at all times. Keep batteries out of the reach of children. Remove all jewelry when servicing batteries.

Before disconnecting the negative (-) ground cable, make sure all switches are OFF. If ON, a spark will occur at the ground cable terminal which could cause an explosion if hydrogen gas or gasoline vapors are present.

⚠ WARNING: Ignition Magnet Is Not Removable or Serviceable!
Do not attempt to remove the ignition magnet from flywheel. Loosening or removing the magnet mounting screws could cause the magnet to come loose and be thrown from the engine causing severe injury. Replace the flywheel if magnet is damaged.



WARNING: Prevent Eye Injury!

Suitable eye protection (safety glasses, goggles, or face hood) should be worn for any procedure involving the use of compressed air, punches, hammers, chisels, drills, or grinding tools.



WARNING: Overspeed Is Hazardous!

The maximum allowable speed for these engines is 3600 RPM, no load. Never tamper with the governor settings to increase the maximum speed. Severe personal injury and damage to the engine or equipment can result if operated at speeds above maximum.



WARNING: Spring Under Tension!

Do not attempt to pull or pry the recoil spring from the starter housing or spring retainer. Doing so can cause the sudden and potentially dangerous release of the spring. Follow the instructions and procedures specified in the "Retractable Starters" section carefully to ensure personal safety and proper spring replacement. Make sure adequate face protection is worn throughout the entire procedure.



WARNING: Spring Under Tension!

Do not remove the center screw of the M8 retractable starter when replacing pawls. Removal of the center screw can cause the sudden and potentially dangerous release of the recoil spring. It is not necessary to remove the center screw when making this repair.

OIL RECOMMENDATIONS

Using the proper type and weight of oil in the crankcase is extremely important, as is checking oil daily and changing oil regularly. Failure to use the correct oil or using dirty oil causes premature engine wear and failure.

Oil Type

Use high quality detergent oil of API (American Petroleum Institute) service class SF or SG. Select the viscosity based on the air temperature at the time of operation as shown below:

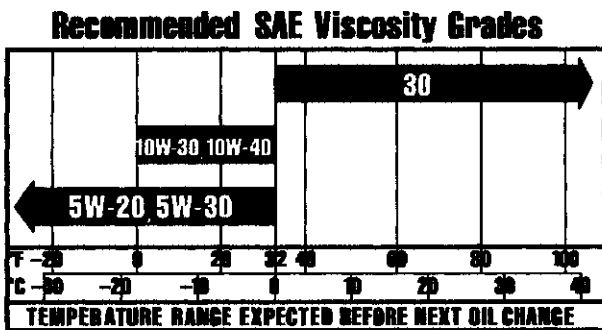

Straight 30-weight oil is recommended. Do not use multi-viscosity oils above 32°F (0°C) as considerable increases in oil consumption and combustion deposits will result.

NOTE: Using other than service class SF or SG oil or extending oil change intervals longer than recommended can cause engine damage which is not covered by the engine warranty.

A logo or symbol on oil containers identifies the API service class and SAE viscosity grade.



Check Oil Level

Check oil level BEFORE EACH USE.

CAUTION: Do not operate the engine with the oil level below "L" mark or over "F" mark on dipstick.

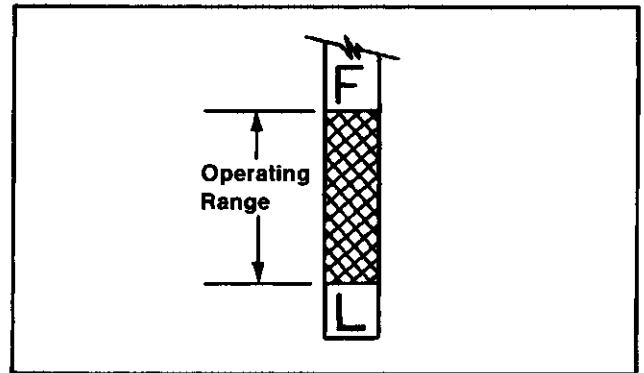

Change Oil

For a new engine, change oil after the first 5 hours of operation. Change oil every 25 operating hours thereafter.

For an overhauled engine or those rebuilt with a new shortblock or miniblock, use straight 30-weight Service Class SF oil for the first 5 hours of operation. Change the oil after this initial run-in period. Refill with Service Class SF oil as specified in the table. Change oil every 25 operating hours thereafter.

Refer to the "Periodic Maintenance" section for detailed oil checking and changing procedures.

FUEL RECOMMENDATIONS

WARNING: Explosive Fuel!



Gasoline is extremely flammable, and its vapors can explode if ignited. Store gasoline only in approved containers, in well-ventilated unoccupied buildings, away from sparks or flames. Do not fill fuel tank while the engine is hot or running since spilled fuel could ignite if it comes in contact with hot parts or sparks from ignition. Do not start engine near spilled fuel; wipe up spills immediately. Never use gasoline as a cleaning agent.

General Recommendations

Purchase gasoline in small quantities and store in clean, approved containers. A container with a capacity of 2 gallons or less with a pouring spout is recommended. Such a container is easier to handle and helps eliminate spoilage during refueling.

Do not use gasoline left over from the previous season, to minimize gum deposits in your fuel system and to insure easy starting.

Do not add oil to the gasoline.

Do not overfill the fuel tank. Leave room for the fuel to expand.

Fuel Type

For best results, use only clean, fresh, unleaded gasoline with a pump sticker octane rating of 87 or higher. In countries using the Research method, it should be 90 octane minimum.

OVERALL DIMENSIONS

Model M8 With Side Tank

Unleaded gasoline is recommended, as it leaves less combustion chamber deposits. Leaded gasoline may be used in areas where unleaded is not available and exhaust emissions are not regulated. Be aware however, that the cylinder head will require more frequent service.

Gasoline/Alcohol blends

Gasohol (up to 10% ethyl alcohol, 90% unleaded gasoline by volume) is approved as a fuel for Kohler engines. Other gasoline/alcohol blends are not approved.

Gasoline/Ether blends

Methyl Tertiary Butyl Ether (MTBE) and unleaded gasoline blends (up to a maximum of 15% MTBE by volume) are approved as a fuel for Kohler engines. Other gasoline/ether blends are not approved.

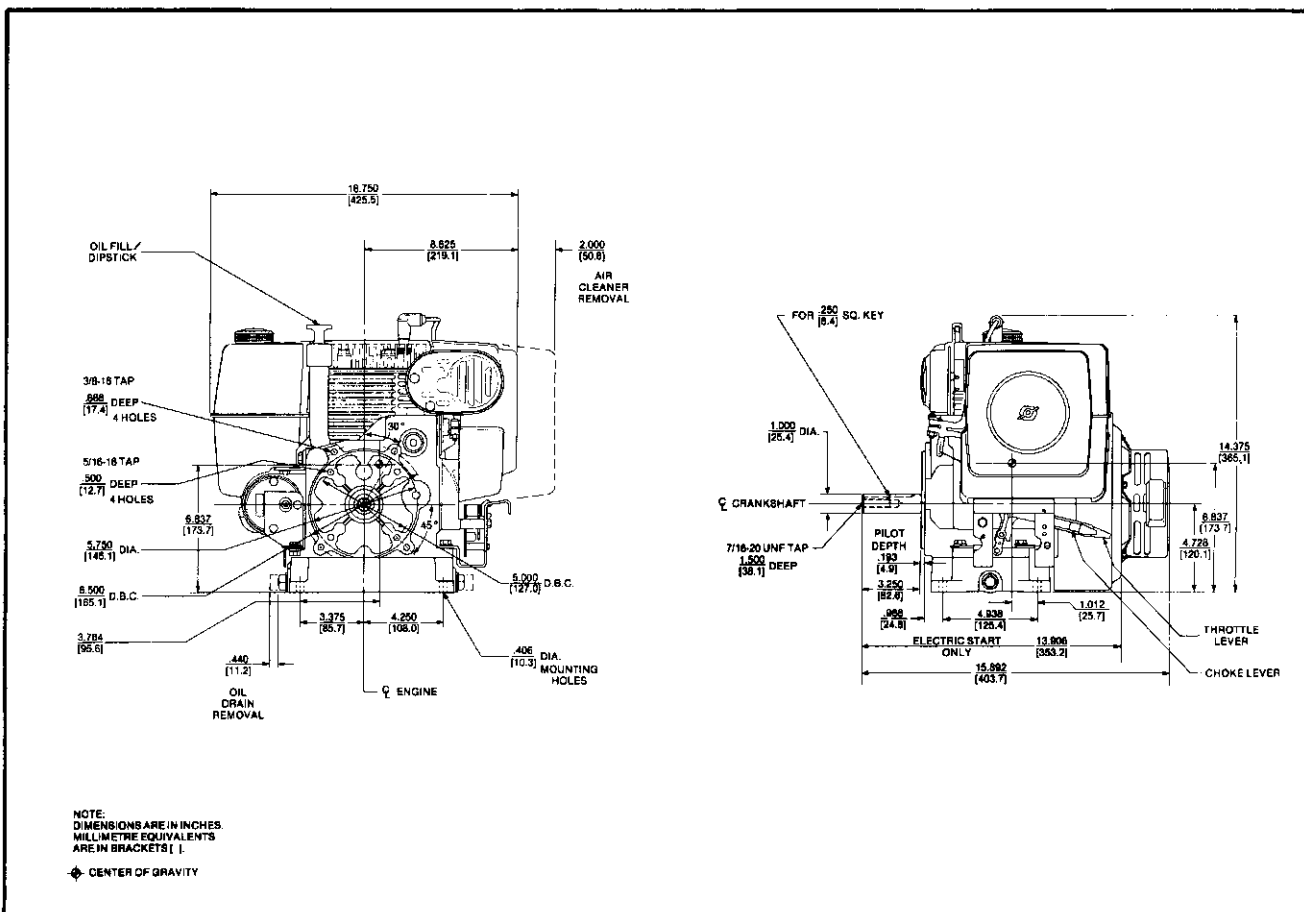

Figure 1-3. Overall Dimensions - Model M8 With Side Tank.

Model M8 With Top Tank

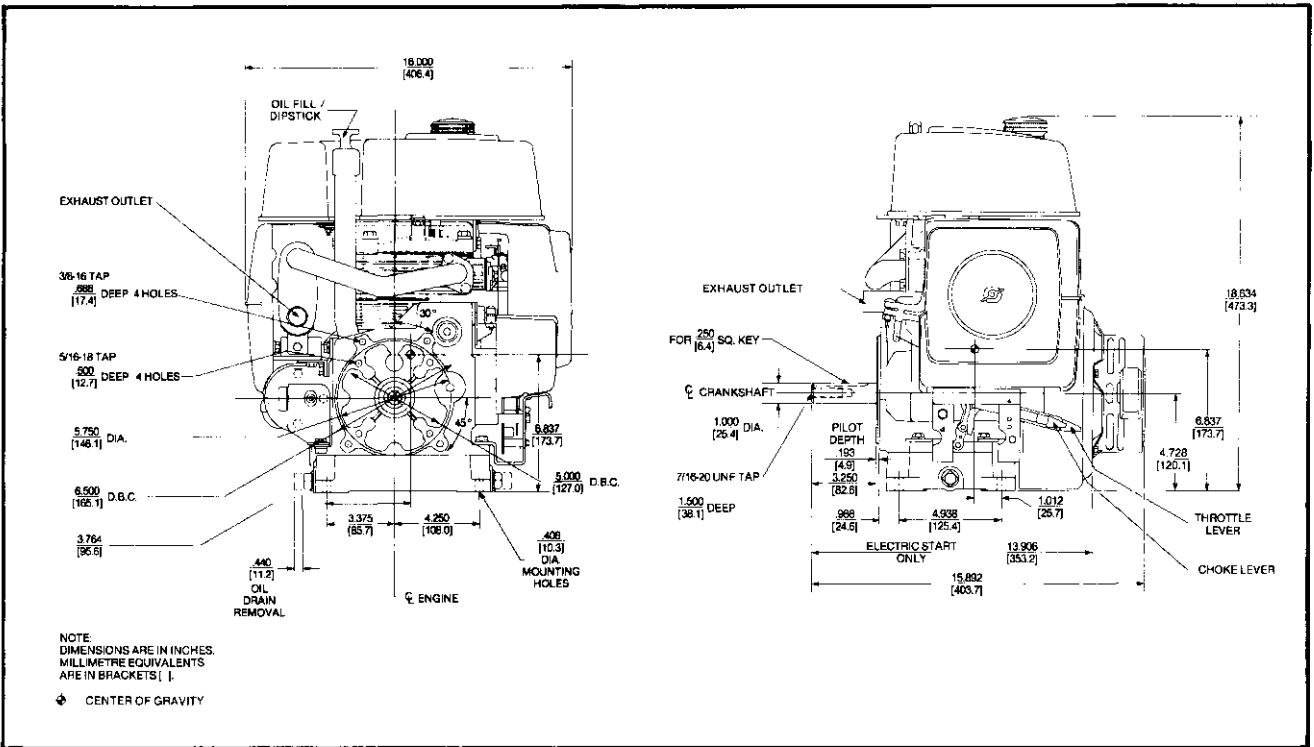

Figure 1-4. Overall Dimensions - Model M8 With Top Tank.

Model M10, M12, M14, And M16

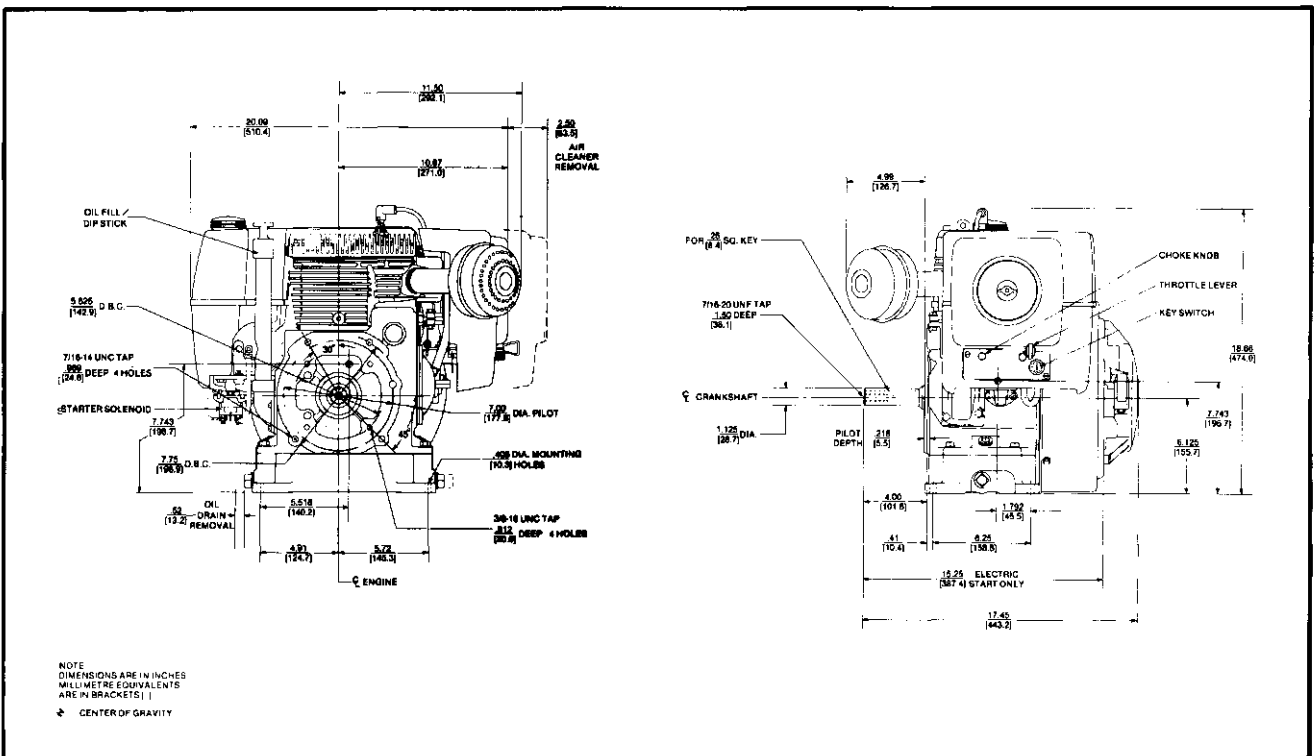

Figure 1-5. Overall Dimensions - Models M10, M12, M14, and M16.

STANDARD TORQUE VALUES¹

Bolts, Screws, Nuts, and Fasteners Assembled Into Cast Iron or Steel



Size	Grade 2	Grade 5 ³	Grade 8
#8-32	20 in. lb.	25 in. lb.	—
#10-24	32 in. lb.	40 in. lb.	—
#10-32	32 in. lb.	40 in. lb.	—
1/4-20	70 in. lb.	115 in. lb.	165 in. lb.
1/4-28	85 in. lb.	140 in. lb.	200 in. lb.
5/16-18	150 in. lb.	250 in. lb.	350 in. lb.
5/16-24	165 in. lb.	270 in. lb.	30 ft. lb.
3/8-16	260 in. lb.	35 ft. lb.	50 ft. lb.
3/8-24	300 in. lb.	40 ft. lb.	60 ft. lb.
7/16-14	35 ft. lb.	55 ft. lb.	80 ft. lb.
7/16-20	45 ft. lb.	75 ft. lb.	105 ft. lb.
1/2-13	50 ft. lb.	80 ft. lb.	115 ft. lb.
1/2-20	70 ft. lb.	105 ft. lb.	165 ft. lb.
9/16-12	75 ft. lb.	125 ft. lb.	175 ft. lb.
9/16-18	100 ft. lb.	165 ft. lb.	230 ft. lb.
5/8-11	110 ft. lb.	180 ft. lb.	260 ft. lb.
5/8-18	140 ft. lb.	230 ft. lb.	330 ft. lb.
3/4-10	150 ft. lb.	245 ft. lb.	350 ft. lb.
3/4-16	200 ft. lb.	325 ft. lb.	470 ft. lb.

Bolts, Screws, Nuts, and Fasteners Assembled Into Aluminum



Size	Grade 2	Grade 5	Grade 8
#8-32	20 in. lb.	20 in. lb.	20 in. lb.
#10-24	32 in. lb.	32 in. lb.	32 in. lb.
1/4-20	70 in. lb.	70 in. lb.	70 in. lb.
5/16-18	150 in. lb.	150 in. lb.	150 in. lb.

Oil Drain Plugs⁴

Size	Into Cast Iron Pans	Into Aluminum Pans
1/4"	150 in. lb.	100 in. lb.
3/8"	180 in. lb.	120 in. lb.
1/2"	20 ft. lb.	13 ft. lb.
3/4"	25 ft. lb.	16 ft. lb.
X-708-1 ⁵	20/25 ft. lb.	20/25 ft. lb.

Conversions

ft. lb. = in. lb. x 0.083
in. lb. = ft. lb. x 12
kgm = ft. lb. x 0.1383
Nm. = ft. lb. x 1.3558

SPECIFICATIONS, TOLERANCES, AND SPECIAL TORQUE VALUES²

General	Model M8	Model M10	Model M12	Model M14	Model M16
Horsepower (@ 3,600 rpm)	8	10	12	14	16
Displacement (cu. in.)	18.64	23.85	29.07	31.27	35.9
Bore	2.94	3.25	3.38	3.50	3.75
Stroke	2.75	2.88	3.25	3.25	3.25
Compression Ratio	6.8:1	6.2:1	6.6:1	7.0:1	7.3:1
Approx. Weight (lb.)	71	129	129	129	129
Approx. Oil Capacity* (U.S. Quarts)	1	2	2	2	2
Approx. Fuel Tank Capacity (U.S. Gallons)	1.25	1.5	1.5	1.5	1.5

⁴For best results, fill to "F" mark on dipstick as opposed to adding a given quantity of oil.
Always check level on dipstick before adding more oil.

	Model M8	Model M10	Model M12	Model M14	Model M16
Air Cleaner					
Element Cover Nut					
Torque (in. lb.)	50	50	50	50	50
Angle of Operation - Maximum (At Full Oil Level; Intermittent Operation) With Oil Sentry™					
Carb. Side Up	15°	15°	15°	15°	15°
Carb. Side Down	35°	23°	23°	23°	23°
Flywheel End Up	35°	30°	30°	30°	30°
Flywheel End Down	45°	45°	45°	45°	45°
Without Oil Sentry™					
Carb. Side Up	45°	45°	45°	45°	45°
Carb. Side Down	35°	23°	23°	23°	23°
Flywheel End Up	35°	30°	30°	30°	30°
Flywheel End Down	45°	45°	45°	45°	45°
Balance Gear					
End Play	—	.002/.010	.002/.010	.002/.010	.002/.010
New Stub Shaft O.D.	—	.4998/.5001	.4998/.5001	.4998/.5001	.4998/.5001
Stub Shaft O.D. Max Wear Limit	—	.4996	.4996	.4996	.4996
Camshaft					
End Play	.005/.010	.005/.010	.005/.010	.005/.010	.005/.010
Camshaft to Camshaft Pin Running Clearance	.0010/.0035	.0010/.0035	.0010/.0035	.0010/.0035	.0010/.0035
Camgear Cover Fastener Torque (in. lbs.)	—	115	115	115	115
Camshaft Pin Depth From Crankcase Surface	.275/.285	.300/.330	.300/.330	.300/.330	.300/.330
Cup Plug Depth from Crankcase Surface	.055/.065	.000/.030	.000/.030	.000/.030	.000/.030
Carburetor					
Preliminary Main Fuel Screw Setting (Turns)	2	1-1/2	1-1/2	2-1/2	2-1/2
Preliminary Idle Fuel Screw Setting (Turns)	1-1/4	2-1/2	2-1/2	2-1/2	2-1/2
Float Level	11/64 (± 1/32)	11/64 (± 1/32)	11/64 (± 1/32)	11/64 (± 1/32)	11/64 (± 1/32)
Float Drop	1-1/32	1-1/32	1-1/32	1-1/32	1-1/32
Fuel Inlet Seat Torque (in. lb.)	35	35	35	35	35
Bowl Retaining Screw Torque (in. lb.)	50	50	50	50	50
Float to Float Pin Tower Clearance	.010	.010	.010	.010	.010
Connecting Rod (Posi-Lock)					
New Service Rod Nut Torque (in. lb.) ^{4+ 6}	140	260	260	260	260
Used Rod Nut Torque (in. lb.) ^{4+ 6}	100	200	200	200	200
Rod to Crankpin Running Clearance - New	.001/.002	.001/.002	.001/.002	.001/.002	.001/.002
Rod to Crankpin Max. Wear Limit	.0025	.0025	.0025	.0025	.0025
Rod to Piston Pin Running Clearance - New	.0006/.0011	.0003/.0008	.0003/.0008	.0003/.0008	.0003/.0008
Piston Pin End I.D. - New	.6255/.6258	.8596/.8599	.8757/.8760	.8757/.8760	.8757/.8760
Rod Side Play on Crankpin	.005/.016	.007/.016	.007/.016	.007/.016	.007/.016

	Model M8	Model M10	Model M12	Model M14	Model M16
Crankshaft					
Crankshaft End Play002/.023	.003/.020	.003/.020	.003/.020	.003/.020
Main Bearing Surface					
O.D. - New	1.1811/1.1814	1.5745/1.5749	1.5745/1.5749	1.5745/1.5749	1.5745/1.5749
Main Bearing Surface Max.					
Wear Limit	1.1811	1.5745	1.5745	1.5745	1.5745
Crankpin O.D. - New	1.1860/1.1855	1.5000/1.4995	1.5000/1.4995	1.5000/1.4995	1.5000/1.4995
Crankpin O.D. Max.					
Out of Round0005	.0005	.0005	.0005	.0005
Crankpin O.D. Max. Taper001	.001	.001	.001	.001
Cylinder Bore					
I.D. - New	2.9380/2.9370	3.2515/3.2505	3.3755/3.3745	3.5005/3.4995	3.7505/3.7495
I.D. Max. Wear Limit	2.941	3.254	3.378	3.503	3.753
I.D. Max. Out of Round005	.005	.005	.005	.005
I.D. Max. Taper003	.002	.002	.002	.002
Cylinder Head					
Cap Screw Torque					
(ft. lb.) ⁴	15/20	25/30	25/30	25/30	25/30
Max. Out of Flatness003	.003	.003	.003	.003
Fan/Flywheel					
Fan Fastener					
Torque (in. lbs.)	115	115	115	115	115
Flywheel Fastener					
Torque (ft. lb.) ⁴	85/90	40/45	40/45	40/45	40/45
Fuel Pump					
Mounting Screw					
Torque (in. lb.)	40/45	40/45	40/45	40/45	40/45
Fuel Tank					
Isolation Mount Torque	Hand Tight ⁷	Hand Tight	Hand Tight	Hand Tight	Hand Tight
Upper Bracket to Tank					
Fastener Torque (in. lb.)	90	—	—	—	—
Lower Bracket to Tank					
Fastener Torque (in. lb.)	90	—	—	—	—
Lower Bracket to Crankcase					
Bracket Fastener Torque (in. lb.)	70	—	—	—	—
Top Tank Bracket to Cyl.					
Head Fastener Torque (in. lb.)	150	—	—	—	—
Gear Reduction Unit					
Gear Reduction Shaft					
End Play001/.030	.008/.030	.005/.030	.005/.030	.005/.030
Governor					
Governor Bushing					
Torque (in. lb.)	100/120	100/120	100/120	100/120	100/120
Governor Bushing to Cross					
Shaft Running Clearance0005/.0020	.0010/.0025	.0010/.0025	.0010/.0025	.0010/.0025
Governor Gear to Stub					
Shaft Running Clearance0005/.0020	.0005/.0020	.0005/.0020	.0005/.0020	.0005/.0020
Governor Cross Shaft					
End Play001/.056	.001/.069	.001/.069	.001/.069	.001/.069

	Model M8	Model M10	Model M12	Model M14	Model M16
Ignition					
Ignition Module to					
Magnet Air Gap012/.016	.012/.016	.012/.016	.012/.016	.012/.016
Spark Plug Type					
(Champion® or Equiv.)	RCJ-8	RH-10	RH-10	RH-10	RH-10
Spark Plug Gap025	.025	.025	.025	.025
Spark Plug Torque (ft. lb.)	18/22	18/22	18/22	18/22	18/22
Ignition Module Mounting					
Screw Torque (in. lbs.)	32	32	32	32	32
Keyswitch Nut Torque					
(in. lbs.)	—	90/100	90/100	90/100	90/100
Oil Pan/Oil Sentry™					
Oil Sentry Switch Max.					
Torque (in. lb.) ¹⁰	90	90	90	90	90
Piston and Piston Rings					
(Style "A" Pistons)					
Thrust Face O.D. @ D1					
- New ¹¹	2.9297/2.9281	3.2432/3.2413	3.368/3.365	3.4941/3.4925	—
Thrust Face O.D. @ D1 - Max. ¹¹					
Wear Limit	2.925	3.238	3.363	3.491	—
Thrust Face to Bore					
Clearance @ D1 - New ¹¹007/.010	.007/.010	.007/.010	.007/.010	—
Piston Ring End Gap - New007/.017	.010/.020	.010/.020	.010/.020	—
Piston Ring End Gap -					
Used (Max.)027	.030	.030	.030	—
Piston Ring Side					
Clearance - Max.006	.006	.006	.006	—
Piston Pin O.D. - New6247/.6249	.8591/.8593	.8752/.8754	.8752/.8754	—
Piston and Piston Rings					
(Styles "C" And "D" Pistons)					
Thrust Face O.D. @ D1					
- New ¹²	2.9336/2.9329	—	—	—	3.7455/3.7465
Thrust Face O.D. @ D1					
- Max. Wear Limit ¹²	2.9312	—	—	—	3.7435
Thrust Face to Bore					
Clearance @ D1 - New ¹²0034/.0051	—	—	—	.0030/.0050
Piston Ring End Gap - New ⁹010/.023	—	—	—	.010/.020
Piston Ring End Gap					
- Used (Max.) ⁹032	—	—	—	.030
Piston Ring Side					
Clearance - Max.006	—	—	—	.006
Piston Pin O.D. - New6247/.6249	—	—	—	.8752/.8754
Valves and Tappets					
Intake Valve to Tappet					
Clearance - Cold006/.008	.008/.010	.008/.010	.008/.010	.008/.010
Exhaust Valve to Tappet					
Clearance - Cold017/.019	.017/.019	.017/.019	.017/.019	.017/.019
Intake Valve Minimum					
Lift - Zero Lash2718	.318	.318	.318	.318
Exhaust Valve Minimum					
Lift - Zero Lash2482	.318	.318	.318	.318
Intake Valve Minimum					
Stem O.D.3103	.3103	.3103	.3103	.3103
Exhaust Valve Minimum					
Stem O.D.3074	.3074	.3074	.3074	.3074

	Model M8	Model M10	Model M12	Model M14	Model M16
Valves and Tappets (Cont.)					
Nominal Valve Seat Angle	45°	45°	45°	45°	45°
Valve Guide Reamer Size3125	.3125	.3125	.3125	.3125
Intake Valve Guide I.D.					
Max. Wear Limit006	.006	.006	.006	.006
Exhaust Valve Guide I.D.					
Max. Wear Limit008	.008	.008	.008	.008
Throttle Control Lever					
Remote Throttle Control					
Nut Torque (in. lb.) ^a	10/15	10/15	10/15	10/15	10/15
Engine Mtd. Throttle Control					
Nut Torque (in. lb.)	15/25	15/25	15/25	15/25	15/25
Fixed Speed Applications (Shortened Throttle Control)					
Nut Torque (in. lb.)	70	70	70	70	70

Notes:

- Use standard torque values when specific values are not given. Standard values have a tolerance of ± 20%.
- All dimensions are in inches unless otherwise specified.
- Also applies to self-tapping screws.
- Lubricate with oil at assembly.
- 3/8-16 thread with hex head nut and fiber gasket.
- Torque in increments to the value specified. Do not overtorque—loosen—and retorque hex nuts on Posi-Lock connecting rods.
- Top tank models only.
- Torque to value specified; then loosen nut 1/2 turn.
- Top and center compression rings.
- Turn the Oil Sentry™ float switch in approx. 5 to 6 full turns until positioned properly. Refer to the "Electrical System And Components" section for specific installation procedures.
- Measurements @ D1 on Style "A" pistons are made perpendicular to piston pin, just below the oil ring.
- Measurements @ D1 on Styles "C" and "D" pistons are made perpendicular to piston pin in the position shown.

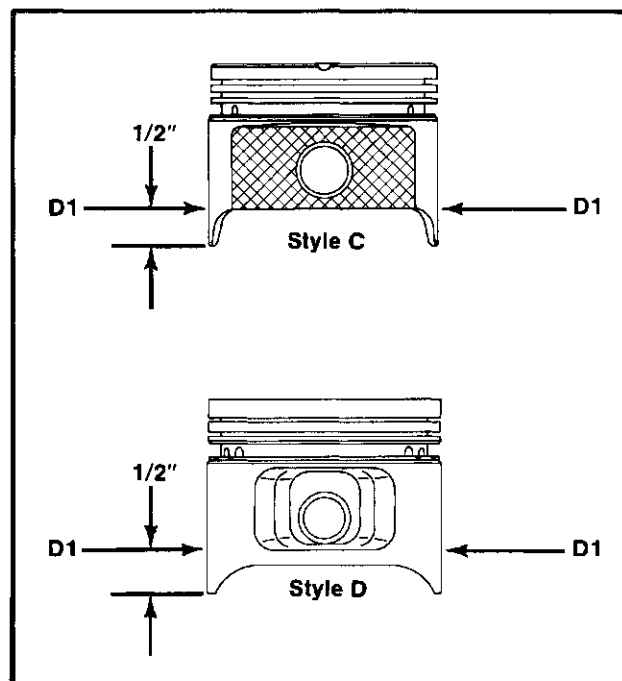
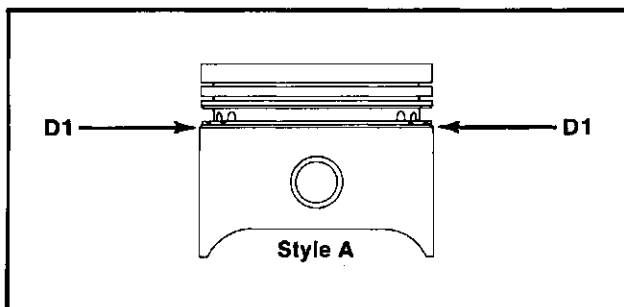

MAGNUM

Single Cylinder Engine
Service Manual
Models M8, M10, M12
M14, M16
TP-2203-A 3/86

KOHLER
engines

SPECIAL TOOLS

2

SPECIAL SERVICE TOOL KIT NO. 3211

These quality tools are designed to help you perform specific disassembly, repair, and reassembly procedures. By using tools designed for the job, you can service engines easier, faster, and safer! In addition, you'll increase your service capabilities and customer satisfaction by decreasing engine down time.

The Special Service Tool Kit No. 3211 can be ordered complete as shown in Figure 2-1 or the tools can be ordered individually. Contact your Kohler Engine Distributor for price and availability.

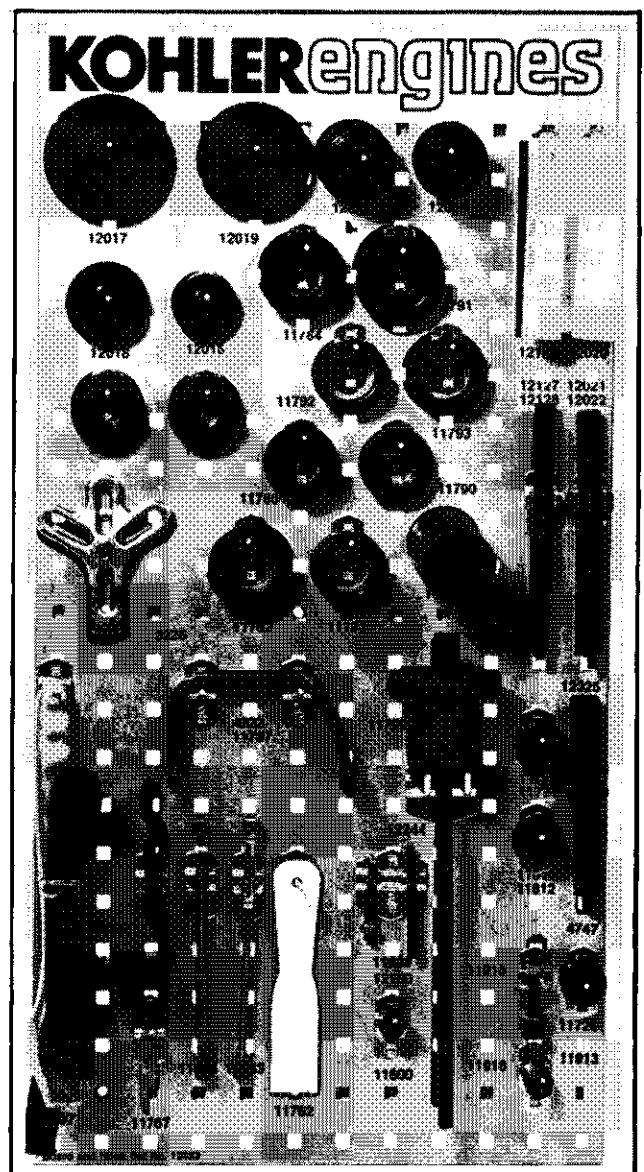

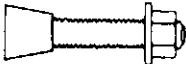

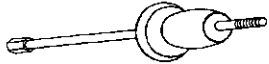
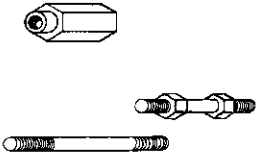
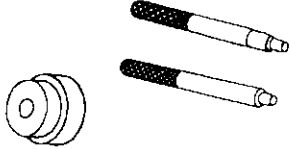
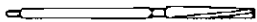
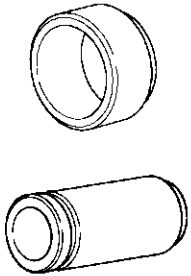

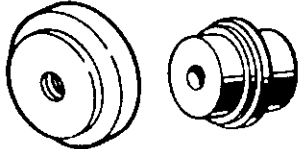
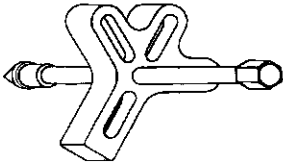

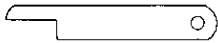

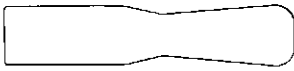



Figure 2-1. Special Service Tool Kit - No. 3211.

VALVE SERVICE TOOLS

TOOL NO. & NAME	APPLICATION	ILLUSTRATION
VALVE SEAT PULLERS 11726 11913	Removal of valve seats, Use 11918 adapter, 3222 slide hammer & 11915 forcing screw	
FORCING SCREW 11915	Used with valve seat pullers 11726 & 11913	
ADAPTER 11918	Used to connect valve seat pullers to slide hammer	
VALVE SEAT INSTALLER 11811 11812	Used to install intake and exhaust seats. Use with 4747 handle	
3222 SLIDE HAMMER 11799 Weight 12244 Slide Bolt	Provides pulling force for valve seat and guide removal. Use 4747 handle.	
3268 VALVE GUIDE REMOVAL KIT 11838 Stud 3 1/2" 12100 Stud 2 1/2" 11800 Adapter 0917 Nut 12008 Nut	Used to pull valve guides with 3222 slide hammer	
3224 VALVE GUIDE INSTALLER KIT 12325 Driver 11763 Driver 11770 Gage 11771 Gage	Used to install valve guides to proper depth. Use 11763 driver with 11770 & 11771 depth gages	
REAMERS (Valve Guide) 11843 5/16" 11844 1/4"	To ream valve guides	
SEAL AND BEARING INSTALLERS		
3223 SEAL INSTALLER KIT 11782 Seal Installer 11783 Seal Installer 11784 Seal Installer 11785 Seal Installer 11786 Seal Installer 11787 Seal Installer 11790 Seal Installer 11791 Seal Installer 11792 Seal Installer 11793 Seal Installer 11795 Handle	Used to install seals without damage and to proper depth. Use 11795 handle with installers	

SEAL AND BEARING INSTALLERS		
TOOL NO. & NAME	APPLICATION	ILLUSTRATION
3242 SEAL PROTECTOR SLEEVE KIT 12020 .75" 12021 1.00 12022 1.25 12126 1.12 12127 1.50 12128 1.44	Used on crankshaft when installing seals to prevent damage	
3241 BEARING INSTALLING KIT 12014 Ins. (Crank Bushing) 12015 Ins. (Cam Bushing) 12016, 12017, 12018 & 12109 Brg. Installers	Used to install & remove engine bearings and bushings	
OTHER APPLICATIONS		
3226 FLYWHEEL PULLER KIT 12485 Puller w/forcing screw 5108 Bolt - 1/4" w/washer (3) 12505 Bolt - 10-24 w/washer (2) 12504 Bolt - 3/8" w/washer (2) 12506 Storage Bag	Used to remove flywheels and bearing plates from engine	
FLYWHEEL STRAP WRENCH 10357	Used to hold flywheel for nut removal	
OFFSET WRENCH 11797 Wrench 1/2" 4923 Wrench 9/16"	Used to remove & install cylinder barrel retaining nuts	
FEELER GAGE 11767	Used to set oil pump drive gear backlash on twin cylinder engine	
TIMING GAGE 10355 Timing Gage	Used to hold balance gears in timed position when assembling engine	
SCRAPER 11762	Used to scrape machined surfaces without damage	
HANDLE 4747 Handle	Used with bearing installers, slide hammer, and valve seat installers	
TOOL BOARD AND HOOK SET 12033	Used to store and identify tools	SEE FRONT PAGE

KIT NO. 3211

TOOL USAGE CHART

PART NO & NAME	MODEL ("K" SERIES)										MODELS ("M" SERIES)							
	K-91	K-161	K-181	K-241	K-301	K-321	K-341	KT-17	KT-19	K-532	K-582	M-8	M-10	M-12	M-14	M-16	M-18	M-20
VALVE TOOLS																		
11726 Valve Seat Puller		●	●	●	●	●	●	●	●	●	●	●	●	●	●	●	●	●
11913 Valve Seat Puller		●	●	●	●	●	●					●	●	●	●			
11915 Forcing Screw		●	●	●	●	●	●	●	●	●	●	●	●	●	●	●	●	●
11918 Adapter		●	●	●	●	●	●	●	●	●	●	●	●	●	●	●	●	●
11811 Valve Seat Installer		●	●	●	●	●	●	●	●	●	●	●	●	●	●	●	●	●
11812 Valve Seat Installer	●																	
3222 Slide Hammer		●	●	●	●	●	●	●	●	●	●	●	●	●	●	●	●	●
3268 Valve Guide Removal Kit		●	●	●	●	●	●	●	●	●	●	●	●	●	●	●	●	●
12325 Valve Guide Driver		●	●	●	●	●	●	●	●	●	●	●	●	●	●	●	●	●
11763 Valve Guide Driver (depth)								●	●								●	●
11770 Valve Guide Depth Gage								●	①								●	
11771 Valve Guide Depth Gage									●								●	
11843 Valve Guide Reamer 5/16"		●	●	●	●	●	●	●	●	●	●	●	●	●	●	●	●	●
11844 Valve Guide Reamer 1/4"	●																	

① KT19 engines prior to Series II (Spec No. 49199 and lower).

BEARING AND SEAL INSTALLERS

12014 Installer — Crank Bushing										●	●							
12015 Installer — Cam Bushing										●	●							
12016 Installer — Bearing	●																	
12017 Installer — Bearing (PTO)										●	●							
12018 Installer — Bearing		●	●									●						
12019 Installer — Bearing				●	●	●	●						●	●	●	●		
11782 Installer — Seal (PTO)								●	●							●	●	
11783 Installer — Seal (Flywheel)								●	●							●	●	
11784 Installer — Seal (PTO)				●	●	●	●					●	●	●	●			
11785 Installer — Seal (PTO)		●	●									●						
11786 Installer — Seal (Flywheel)	●																	
11787 Installer — Seal (PTO)	●																	
11790 Installer — Seal (Flywheel)		●	●									●						
11791 Installer — Seal (PTO)										●	●							
11792 Installer — Seal (Flywheel)				●	●	●	●					●	●	●	●			
11793 Installer — Seal (Flywheel)										●	●							
11795 Handle — Installer Seal	●	●	●	●	●	●	●	●	●	●	●	●	●	●	●	●	●	
12020 Seal Sleeve																		
12021 Seal Sleeve																		
12022 Seal Sleeve																		
12126 Seal Sleeve																		
12127 Seal Sleeve																		
12128 Seal Sleeve																		

MISCELLANEOUS TOOLS

10357 Flywheel Strap Wrench 1/2"	●	●	●	●	●	●	●	●	●	●	●	●	●	●	●	●		
11797 Offset Wrench 1/2"								●	●								●	●
4923 Offset Wrench 9/16"								●	●									
11767 Feeler Gauge-Crank(Oil Pump)										●	●							
10355 Timing Tool (Balance Gear)				●	●	●	●					●	●	●	●			
11762 Scraper	●	●	●	●	●	●	●	●	●	●	●	●	●	●	●	●	●	
4747 Drive Handle	●	●	●	●	●	●	●	●	●	●	●	●	●	●	●	●	●	
3226 Flywheel Puller Kit	●	●	●	●	●	●	●	●	●	●	●	●	●	●	●	●	●	

ENGINE ANALYSIS KIT NO. 25 800 01

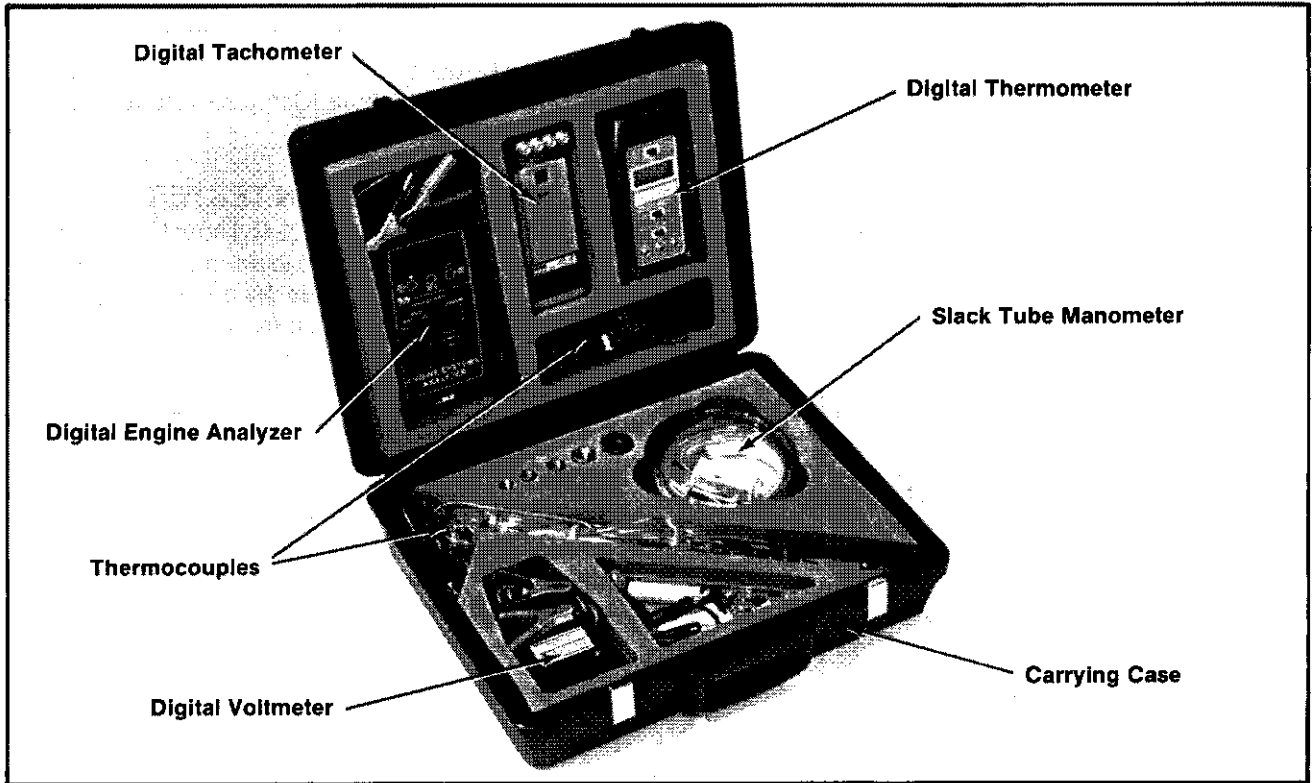

Figure 2-2. Engine Analysis Kit - No. 25 800 01.

The Kohler Engine Analysis Kit contains a selection of instruments which will enable you to measure critical items that relate to engine performance. You will find many uses for these instruments—from basic crankcase vacuum checks to sophisticated application tests.

The kit includes the following:

Qty.	Description	Part No.
1	Digital Voltmeter	25 800 02
1	Digital Tachometer	25 800 03
1	Digital Thermometer	25 800 04
1	Digital Engine Analyzer	25 800 05
1	Slack Tube Manometer	25 800 06
1	8 Ft. Lead With Plug	25 800 07
3	14 mm Spark Plug	
	Thermocouple	25 800 08
2	Head Bolt Thermocouple	25 800 09
1	Oil Sump Thermocouple	25 800 10
1	1/4" x 1/8" Bushing	25 800 11
1	3/8" x 1/8" Bushing	25 800 12
1	1/2" x 1/8" Bushing	25 800 13
1	3/4" x 1/8" Bushing	25 800 14
1	Tube With Fittings	25 800 15
1	Carrying Case	25 800 16
3	Plain Thermocouple	25 800 17

The voltmeter, tachometer, thermometer, and engine analyzer feature state of the art electronic circuitry and digital readouts. Guidelines for using the instruments and testing are included.

Using the instruments in the kit you will be able to:

- Measure temperatures of—
 - spark plug base gasket/cylinder head bolt.
 - oil sump.
 - air into flywheel and carburetor.
- Measure engine speed (RPM).
- Measure crankcase vacuum and exhaust system back pressure.
- Measure voltage.
- Measure charging system current.
- Measure electric starter current (Amp) draw.

The Engine Analysis kit can be ordered complete as shown, or the instruments can be ordered individually. Contact your Kohler Distributor for price and availability.

IGNITION SYSTEM TESTER

These engines are equipped with a dependable electronic magneto ignition system. Ignition tester 25 455 01 can be used to determine if the ignition module is functioning properly. See Figure 2-3.

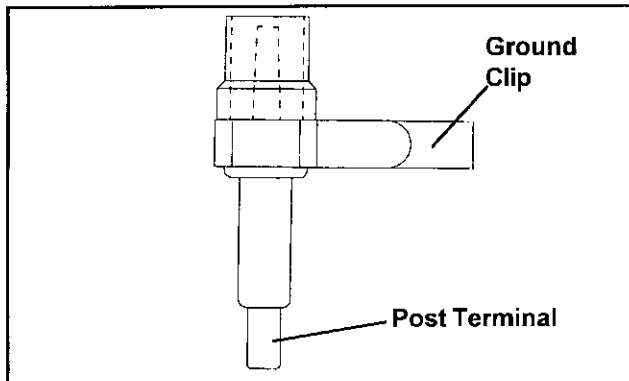

Figure 2-3. Electronic Magneto Ignition System Tester.

Using The Tester

1. Disconnect spark plug lead and connect it to the post terminal of tester. Connect the ground clip to a good ground, not to the spark plug.

NOTE: To maintain engine speeds normally obtained during cranking, do not remove the engine spark plug.

2. Make sure the engine ignition switch, kill switch, or key switch is in the "run" position.
3. Crank the engine and observe the test plug. Visible and audible sparks should be produced. **Do not** touch tester during cranking.

WATER MANOMETER

The Kohler Part No. 25 761 02 U-Tube water manometer is a useful tool to check crankcase vacuum (or pressure) and to check for exhaust back pressure. It can also be used to adjust primary regulators used with gaseous fuel systems. Complete instructions are provided in the kit.

CYLINDER LEAKDOWN TESTER

The Kohler Part No. 25 761 05 Cylinder Leakdown Tester is a valuable alternate to a compression test on these ACR equipped engines. By pressurizing the combustion chamber from an external air source, this tool can determine if valves or rings are leaking. Instructions for using this tester are included with the tester.

INDUCTANCE TACHOMETER

The Kohler Part No. 25 761 03 is a hand-held inductance tachometer that can be used to obtain accurate RPM readings on all Kohler engines.

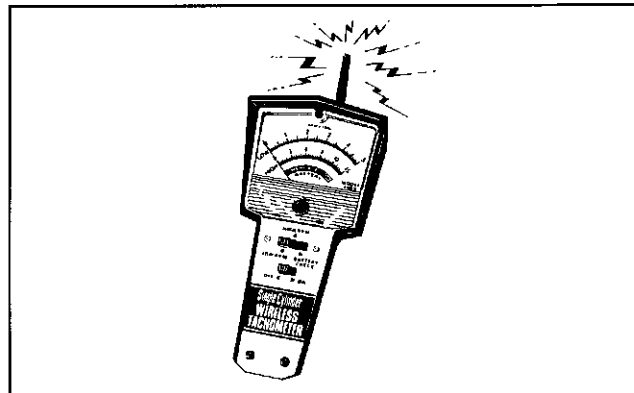

MAGNUM
 Single Cylinder Engine
 Service Manual
 Models M8, M10, M12
 M14, M16
 TP-2203-A 3/86

PERIODIC MAINTENANCE

REQUIRED MAINTENANCE

These required maintenance procedures should be performed at the frequency stated in the table:

Required Maintenance	Frequency
Check Oil Level	Daily
Clean Grass Screen	Daily*
Check/Replace Fuel Filter	As Required
Clean Foam Precleaner	25 Hours*
Change Oil	25 Hours
Check Optional Reduction Gear Unit	50 Hours
Clean Cooling Fins and External Surfaces	50 Hours*
Clean Paper Air Cleaner Element	100 Hours*
Check Spark Plug	100 Hours
Check Valve-To-Tappet Clearance	500 Hours
Clean Cylinder Head and Combustion Chamber	500 Hours**
Service Starter Motor Drive	Annually or 500 Hours

*Perform these maintenance procedures more frequently when engine is operated under extremely dusty and dirty conditions.

**250 Hours when leaded gasoline is used.

WARNING: Accidental Starts!



Before servicing the engine or equipment, always remove the spark plug lead to prevent the engine from starting accidentally. Ground the lead to prevent sparks that could cause fires.

CHECK OIL LEVEL

The importance of checking and maintaining the proper oil level in crankcase cannot be overemphasized. Check oil **BEFORE EACH USE** as follows:

1. Make sure the engine is stopped, level, and is cool so the oil has had time to drain into the sump.
2. Clean the area around oil fill cap/dipstick before removing to keep dirt, grass clippings, etc., out of the engine.

3. Remove oil fill cap/dipstick; wipe oil off. Reinsert dipstick and push it all the way down into tube. Remove dipstick and check the level.

The oil level should be up to, but not over, the "F" mark on the dipstick. Refer to Figure 3-1.

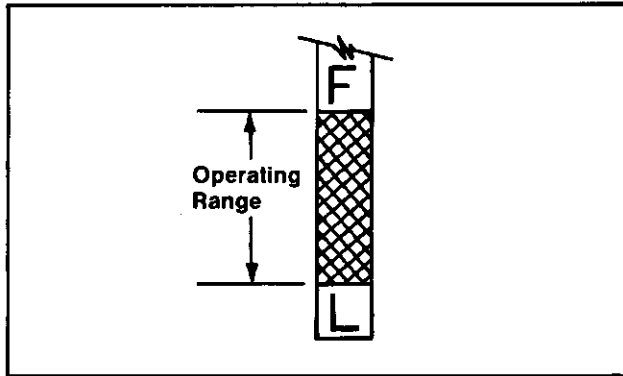

Figure 3-1. Oil Level Range.

4. Add the proper type of oil if the level is low. Always check the level with dipstick before adding more oil.

CAUTION: Never operate the engine with the oil level below "L" mark or over "F" mark on dipstick.

Oil Sentry™



Some engines are equipped with optional Oil Sentry oil level monitor. Oil Sentry will either stop the engine or activate a "low oil" warning light, if the oil level is below the "L" mark on the dipstick. Actual Oil Sentry use will vary depending on the engine application.

CAUTION: Oil Sentry is not a substitute for checking oil BEFORE EACH USE. Make sure the oil level is maintained up to the "F" mark on dipstick.

CHANGE OIL

For a new engine, change oil after the first 5 hours of operation. Change oil every 25 operating hours thereafter.

For an overhauled engine or those rebuilt with a new shortblock or miniblock, use straight 30-weight Service Class SF oil for the first 5 hours of operation. Change the oil after this initial run-in period. Change oil every 25 hours thereafter.

Drain oil while the engine is still warm from operation. The oil will flow more freely and carry away more impurities. Change oil as follows:

1. Remove the oil drain plug and dipstick. Refer to Figure 3-2. Tilt the engine slightly towards the drain hole to obtain better drainage.

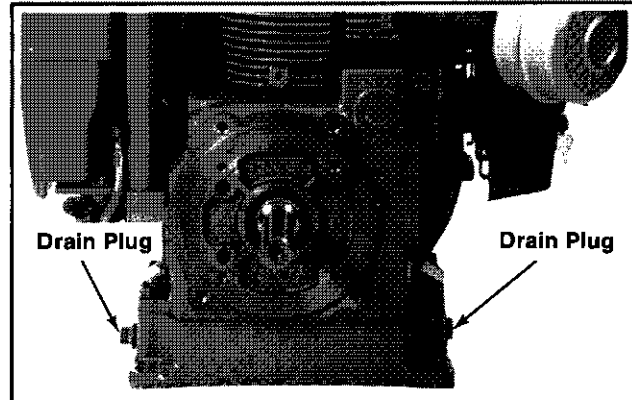

Figure 3-2. Oil Drain Plug Location.

2. Reinstall the drain plug. Make sure it is tightened securely.
3. Fill with new oil of the proper type to the "F" mark on the dipstick. Always check the level on dipstick before adding more oil. Make sure the engine is level when filling and checking oil.

SERVICE AIR CLEANER

Magnum engines are equipped with a high-density paper air cleaner element. Some specifications are also equipped with an oiled foam precleaner which surrounds the paper element. Refer to Figure 3-3.

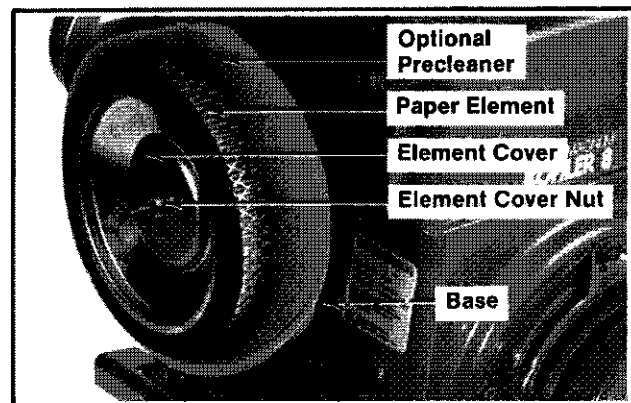

Figure 3-3. Air Cleaner Components.

Precleaner

If so equipped, wash and reoil the precleaner every 25 operating hours (more often under extremely dusty, dirty conditions).

1. Remove precleaner from paper element. Wash the precleaner in warm water with detergent.
2. Rinse precleaner thoroughly until all traces of detergent are eliminated. Squeeze out excess water (do not wring). Allow precleaner to air dry.
3. Saturate precleaner in clean, fresh engine oil. Squeeze out excess oil.
4. Reinstall precleaner over paper element.

Paper Element

Every 100 operating hours (more often under extremely dusty, dirty conditions), check the paper element. Replace the element as follows:

1. Remove the precleaner (if so equipped), element cover, and paper element.
2. Replace a dirty, bent or damaged element with a new genuine Kohler element. Handle new elements carefully; do not use if surfaces are bent or damaged.

CAUTION: Do not wash the paper element or use compressed air as this will damage element.

3. Reinstall the paper element, element cover, and element cover nut. Make sure element is sealed tightly against the element cover and air cleaner base. Tighten nut to **50 in. lbs.** torque.
4. Install the precleaner (cleaned and oiled) over paper element.
5. Install air cleaner cover and wing nut. Tighten wing nut until it is snug against cover—do not overtighten.

Inspect Air Cleaner Components

Whenever the air cleaner cover is removed, or servicing the element or precleaner, check the following components:

- **Air Cleaner Base**—Make sure it is secured tightly to carburetor and is not bent or damaged.
- **Element Cover and Element Cover Nut**—Make sure element cover is not bent or damaged. Make sure element cover nut is secured tightly to seal element between air cleaner base and element cover. Tighten nut to **50 in. lbs.** torque.

- **Breather Tube**—Make sure it is sealed tightly in air cleaner base and breather cover.

CAUTION: Damaged, worn, or loose air cleaner components could allow unfiltered air into the engine causing premature wear and failure. Replace all damaged or worn components.

CLEAN AIR INTAKE/COOLING AREAS

To ensure proper cooling, make sure the grass screen, cooling fins, and other external surfaces of engine are kept clean at all times. Refer to Figure 3-4.

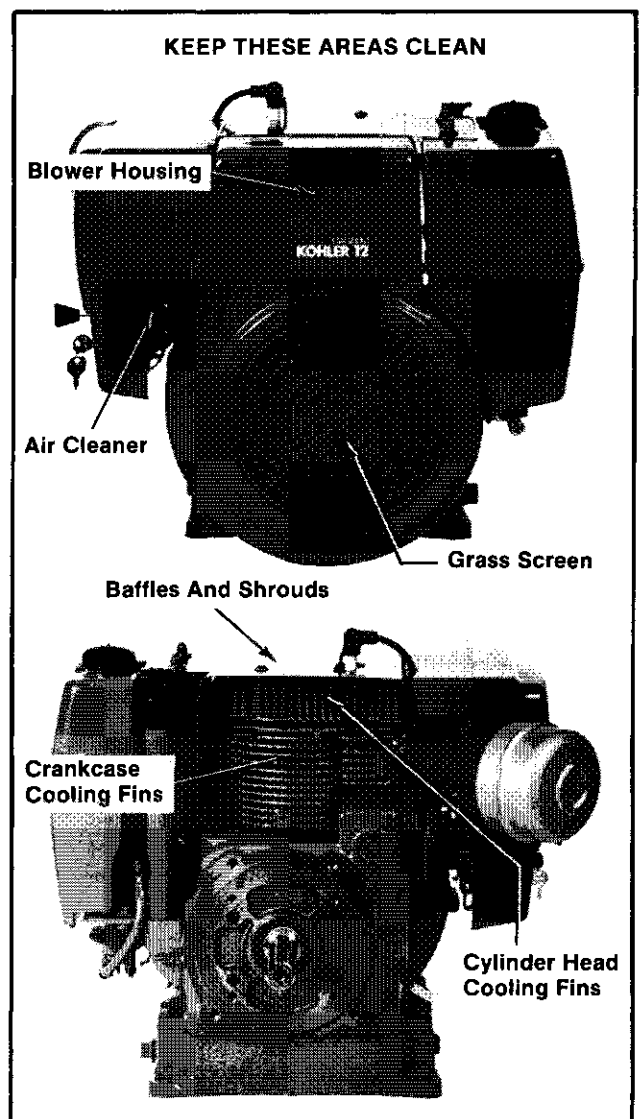

Figure 3-4. Air Intake And Cooling Areas.

Every 50 operating hours (more often under extremely dusty, dirty conditions), remove the blower housing and other cooling shrouds. Clean the cooling fins and external surfaces as necessary. Make sure the cooling shrouds are reinstalled.

Refer to the "Disassembly" and "Reassembly" sections for cooling shroud removal and installation procedures.

CAUTION: Operating the engine with a blocked grass screen, dirty or plugged cooling fins, and/or cooling shrouds removed will cause engine damage due to overheating.

CHECK SPARK PLUG

Every 100 operating hours, remove the spark plug, check its condition, and reset gap or replace with new plug as necessary. Refer to Figure 3-5.

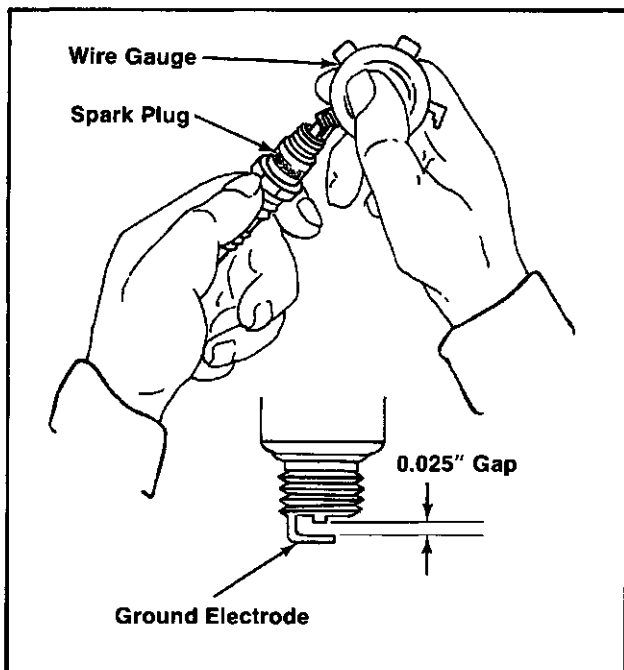

Figure 3-5. Servicing Spark Plug.

1. Before removing spark plug, clean the area around the base of plug to keep dirt and debris out of engine.
2. Remove the plug and check its condition. Replace the plug if worn or if reuse is questionable.

Use Champion® Type (or equivalent):
RCJ-8—On Model M8
RH-10—On Models M10, M12, M14, and M16

CAUTION: Do not clean the spark plug in a machine using abrasive grit. Some grit could remain in spark plug and enter the engine causing extensive wear and damage.

3. Check gap using a wire feeler gauge. Adjust gap to **0.025"** by carefully bending the ground electrode.
4. Reinstall spark plug into cylinder head. Torque plug to **18/22 ft. lb.**

SERVICE OPTIONAL REDUCTION GEAR UNIT

On engines equipped with a reduction gear unit, check the oil level in unit every 50 operating hours. Refer to Figure 3-6.

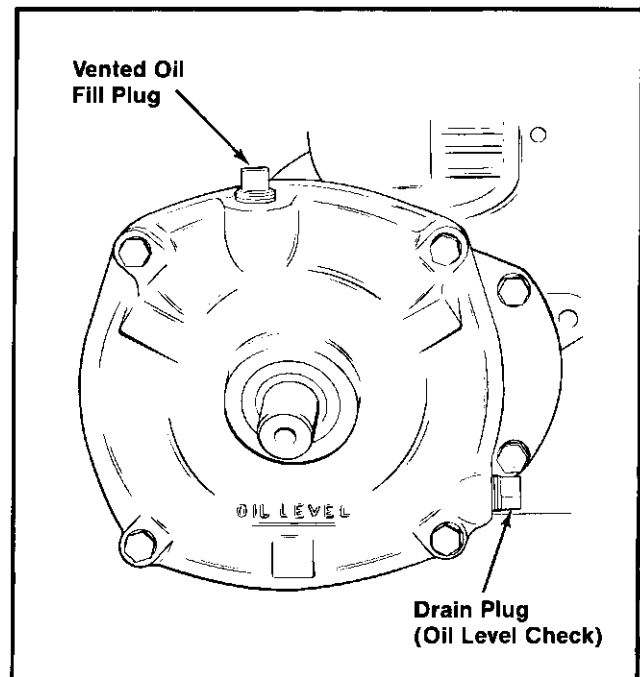

Figure 3-6. Reduction Gear Unit.

1. Remove the plug on the lower part of gear unit cover. With engine level, the oil should be up to the bottom of the plug hole.
2. To add oil, remove the vented fill plug at the top of the unit. Use the same type of oil as used in the engine crankcase.
3. Reinstall and tighten the plugs securely.

IGNITION SYSTEM SERVICE

Magnum engines are equipped with a dependable electronic magneto ignition system. Other than periodically checking/replacing the spark plug, no maintenance, timing, or adjustments are necessary or possible with this system.

CHECK FUEL FILTER

Some engines are equipped with an in-line fuel filter. Visually inspect the filter periodically. Replace when dirty with a genuine Kohler filter.

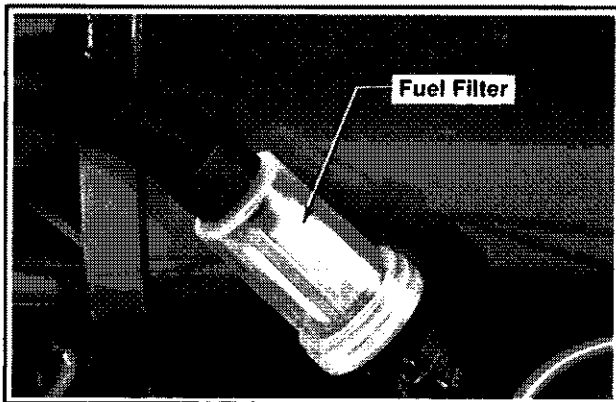

Figure 3-7. In-line Fuel Filter.

SERVICE STARTER MOTOR DRIVE

Every 500 operating hours or annually (whichever occurs first), clean and lubricate the drive splines of the Bendix-drive electric starter motor. Refer to Figure 3-8.

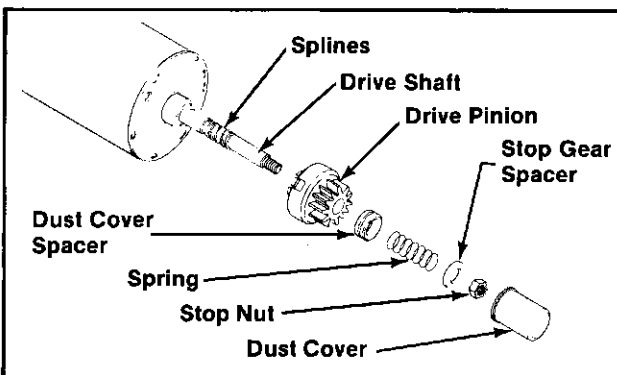

Figure 3-8. Starter Drive Components.

1. Remove starter from bearing plate. (Refer to appropriate "Disassembly" section.)
2. Remove dust cover, stop nut, stop gear spacer, spring, dust cover spacer, and drive pinion.
3. Clean the drive shaft splines with solvent. Dry splines thoroughly.

4. Apply a small amount of Kohler electric starter drive lubricant (Part No. 52 357 01) to splines.

CAUTION: Kohler starter drive lubricant (Part No. 52 357 01) must be used on all Kohler electric starter drives. The use of other lubricants can cause the drive to stick or bind.

5. Apply a small amount of Loctite® No. 271 to stop nut threads. Assemble drive parts in reverse order of removal. Torque stop nut to **160 in. lb.**

6. Reinstall starter to bearing plate. (Refer to appropriate "Reassembly" section.)

CLEAN CYLINDER HEAD AND COMBUSTION CHAMBER

Every 500 operating hours (250 hours when leaded gasoline is used), remove cylinder head and clean combustion chamber. Refer to Figure 3-9.

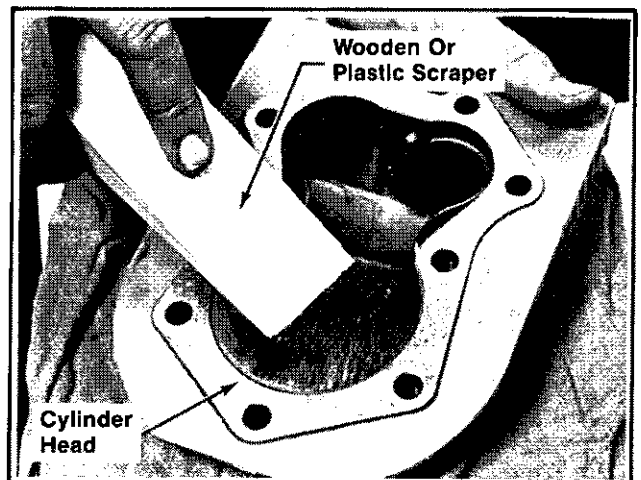

Figure 3-9. Cleaning Cylinder Head And Combustion Chamber.

1. Remove the cylinder head baffle and cylinder head.
2. Clean away combustion deposits using a wooden or plastic scraper.
3. Reinstall the cylinder head using a new gasket. Torque the cylinder head fasteners in sequence to the values specified in Figure 3-10.

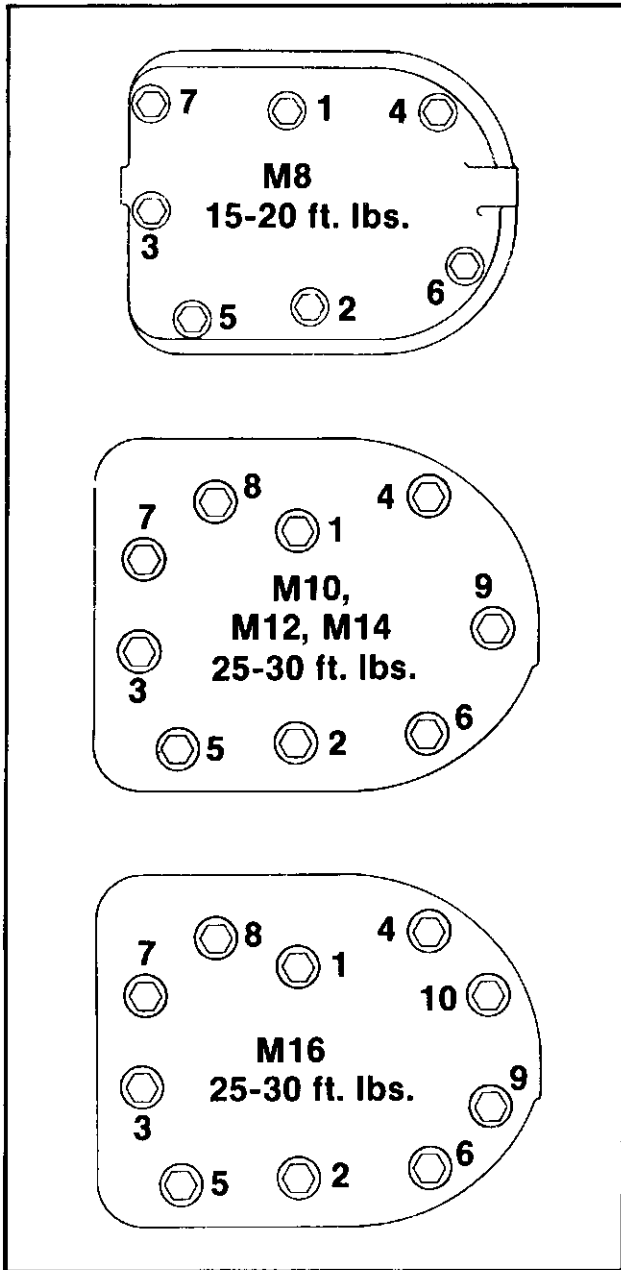

Figure 3-10. Cylinder Head Fastener Tightening Sequence.

CHECK VALVE-TO-TAPPET CLEARANCE

Every 500 operating hours, remove breather/valve cover and check valve-to-tappet clearance with a flat feeler gauge. Refer to Figure 3-11. The engine must be cold when checking this clearance.

1. Remove the air cleaner assembly, carburetor, and breather assembly. (Refer to appropriate "Disassembly" section.)

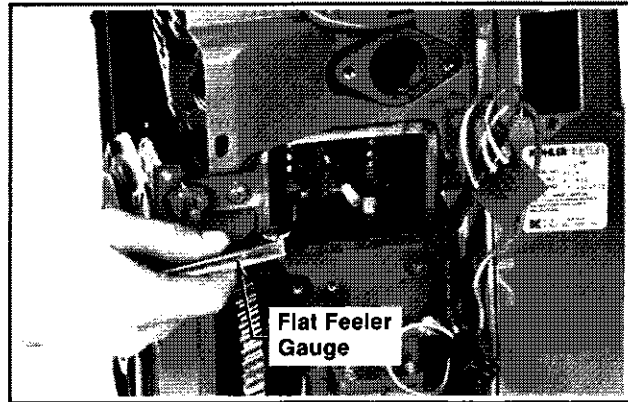

Figure 3-11. Measuring Valve-To-Tappet Clearance.

2. Position the crankshaft so the piston is at top of compression stroke (cam has no effect on tappets).
3. Measure valve-to-tappet clearance with a flat feeler gauge.

Engine Model	Valve-To-Tappet Clearance	
	Intake Valve	Exhaust Valve
M8	.006"/.008"	.017"/.019"
M10, M12, M14, M16	.008"/.010"	.017"/.019"

On Model M8—If clearance is too small, remove the valves and grind the valve stems until the correct clearance is obtained. Make sure valve stems are ground perfectly flat and smooth.

If clearance is too large, replace the valves and recheck clearance.

NOTE: Large clearances can also be reduced by grinding the valves and/or valve seats. Refer to the "Inspection And Repair/Reconditioning" section for valve specifications.

On Models M10, M12, M14, and M16—Adjust the clearance by turning the adjusting screw on tappets. Refer to Figure 3-12.

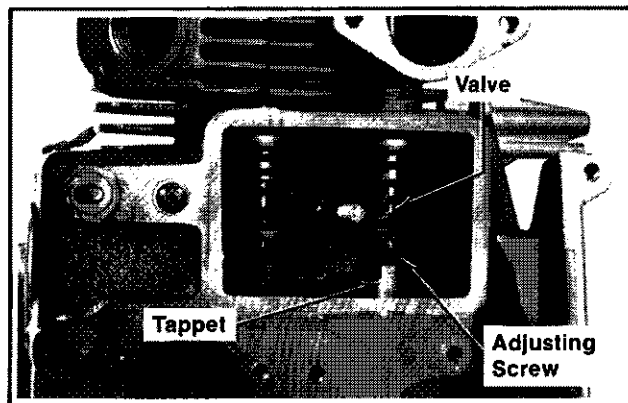

Figure 3-12. Adjusting Valve-To-Tappet Clearance—Models M10, M12, M14, and M16.

STORAGE

If the engine will be out of service for approximately two months or more, use the following storage procedure.

1. Change the oil when engine is still warm from operation. Refer to "Change Oil."
2. Change the oil in reduction gear unit, if so equipped. Refill with the same oil as used in engine crankcase for season of operation. Refer to "Service Optional Reduction Gear Unit." Run engine for a few minutes to distribute clean oil throughout engine.
3. Drain the fuel tank and fuel system (or run engine until fuel tank and fuel system are empty).
4. Remove the spark plug. Add one tablespoon of engine oil into the spark plug hole. Install plug, but do not connect plug lead. Crank the engine two or three revolutions.
5. Remove the spark plug. Cover the spark plug hole with thumb and turn engine over until the piston is at the top of its stroke (pressure against thumb is greatest). Reinstall plug, but do not connect plug lead.
6. Clean the exterior surfaces of engine. Spread a light film of oil over any exposed metal surfaces of engine to prevent rust.
7. Store the engine in a clean, dry place.

MAGNUM

Single Cylinder Engine
Service Manual
Models M8, M10, M12
M14, M16
TP-2203-A 3/86

KOHLER
engines

TROUBLESHOOTING

4

TROUBLESHOOTING GUIDE

When troubles occur, be sure to check the simple causes which, at first, may seem too obvious to be considered. For example, a starting problem could be caused by an empty fuel tank.

Some common causes of engine troubles are listed below—use this as a guide to locate causing factors.

Engine Cranks But Will Not Start

1. Empty fuel tank.
2. Fuel shutoff valve closed.
3. Clogged fuel line.
4. Spark plug lead disconnected.
5. Keyswitch or kill switch in "off" position.
6. Faulty spark plug.
7. Faulty ignition module.
8. Dirt or water in fuel system.

Engine Starts But Does Not Keep Running

1. Restricted fuel tank vent.
2. Dirt or water in fuel system.
3. Faulty choke or throttle controls/cables.
4. Loose wires or connections which short kill terminal of ignition module to ground.
5. Carburetor improperly adjusted.
6. Faulty cylinder head gasket.
7. Faulty fuel pump.

Engine Starts Hard

1. Hydrostatic transmission is not in neutral/PTO drive is engaged.
2. Loose wires or connections.
3. Dirt or water in fuel system.
4. Clogged or restricted fuel lines.
5. Faulty choke or throttle controls/cables.
6. Faulty spark plug.
7. Carburetor improperly adjusted.
8. Incorrect valve-to-tappet clearance.
9. Low compression.
10. Faulty ACR mechanism.

Engine Will Not Crank

1. Hydrostatic transmission is not in neutral/PTO drive is engaged.
2. Battery is discharged.
3. Safety interlock switch is "engaged".
4. Loose or faulty wires or connections.
5. Faulty keyswitch or ignition switch.
6. Faulty electric starter/starter solenoid.
7. Retractable starter not engaging in drive cup.
8. Seized internal engine components.

Engine Runs But Misses

1. Dirt or water in fuel system.
2. Spark plug lead loose.
3. Loose wires or connections which intermittently short kill terminal of ignition module to ground.
4. Carburetor improperly adjusted.
5. Engine overheating.
6. Incorrect valve-to-tappet clearance.
7. Faulty ignition module.

Engine Will Not Idle

1. Idle speed adjusting screw improperly set.
2. Dirt or water in fuel system.
3. Idle fuel adjusting screw improperly set.
4. Restricted fuel tank vent.
5. Faulty spark plug.
6. Incorrect valve-to-tappet clearance.
7. Low compression.

Engine Overheats

1. Grass screen, cooling fins, or shrouding clogged.
2. Excessive engine load.
3. Low crankcase oil level.
4. High crankcase oil level.
5. Carburetor improperly adjusted.

Engine Knocks

1. Low crankcase oil level.
2. Excessive engine load.

Engine Loses Power

1. Low crankcase oil level.
2. High crankcase oil level.
3. Restricted air cleaner element.
4. Dirt or water in fuel system.
5. Excessive engine load.
6. Engine overheating.
7. Faulty spark plug.
8. Carburetor improperly adjusted.
9. Low compression.

Engine Uses Excessive Amount of Oil

1. Incorrect oil viscosity or type.
2. Clogged or improperly assembled breather system.
3. Worn or broken piston rings.
4. Worn cylinder bore.
5. Worn valve stems and/or valve guides.

EXTERNAL ENGINE INSPECTION

Before cleaning or disassembling the engine, check its external appearance and condition. This inspection can give clues to what might be found inside the engine (and the cause) once it is disassembled.

- Check for buildup of dirt and debris on the crankcase, cooling fins, grass screen, and other external surfaces. Dirt or debris in these areas are causes of overheating.
- Check for obvious fuel and oil leaks, and damaged components. Excessive oil leakage can indicate a clogged or improperly assembled breather, worn or damaged seals and gaskets, or loose or improperly torqued fasteners.
- Check the air cleaner cover, element cover, and air cleaner base for damage or indications of improper fit and seal.
- Check the air cleaner element. Look for holes, tears, cracked or damaged sealing surfaces, or other damage that could allow dirt to enter the engine. Also note if the element is clogged or restricted. These could indicate that the air cleaner has been underserviced.
- Check the carburetor throat for dirt. Dirt in the throat is further indication that the air cleaner is not functioning properly.
- Check the oil level. Note if the oil level is within the operating range on the dipstick, or if it's low or overfilled.
- Check the condition of the oil. Drain the oil into a container—it should flow freely. Check for metal chips and other foreign particles.

NOTE: It is good practice to drain oil at a location away from the workbench. Be sure to allow ample time for complete drainage.

Sludge is a natural by-product of combustion; a small accumulation is normal. Excessive sludge formation could indicate that the oil has not been changed as recommended, an incorrect type or weight of oil was used, overrich carburetor settings, and weak ignition, to name a few.

CLEANING THE ENGINE

After inspecting the external condition of the engine, clean it thoroughly before disassembling. Also clean individual components as the engine is disassembled. Only clean parts can be accurately inspected and gauged for wear or damage.

There are many commercially available cleaners that quickly remove grease, oil, and grime from engine parts. When such a cleaner is used, *follow the manufacturer's instructions carefully*. Make sure all traces of the cleaner are removed before the engine is reassembled and placed in operation. Even small amounts of these cleaners quickly break down the lubricating properties of engine oil.

BASIC ENGINE TESTS

Crankcase Vacuum

A partial vacuum should be present in the crankcase when the engine is operating at normal temperatures. Pressure in the crankcase (usually caused by a clogged or improperly assembled breather) can cause oil to be forced out at oil seals, gaskets, or other available spots.

Crankcase vacuum is best measured with a slack tube manometer. The manometer included in the Kohler Engine Analysis kit is recommended. Refer to the "Special Tools" section for more information.

Crankcase Vacuum Test

To test crankcase vacuum with the manometer:

1. Insert the stopper/hose into the oil fill hole. Leave the other vent of manometer open to atmosphere. Make sure the shutoff clamp is closed.
2. Start the engine and run at high speed (3200 to 3600 RPM).

3. Open the clamp and note the water level in the tube. The level in the engine side should be 5 to 10 in. above the level in the open side. If there is no vacuum (level in engine side is the same as open side) or a positive pressure (level in open side is higher than engine side) check for the conditions below.
4. Close the shutoff clamp **before** stopping the engine.

Compression Test

Because single cylinder engines are equipped with an automatic compression release mechanism (ACR), it is difficult to obtain an accurate compression reading.

To check the condition of the combustion chamber and related mechanisms, physical inspection and a crankcase vacuum test are recommended.

NO CRANKCASE VACUUM/PRESSURE IN CRANKCASE

Possible Cause	Solution
1. Crankcase breather clogged or inoperative.	1. Disassemble breather, clean parts thoroughly, reassemble, and recheck pressure.
2. Seals and/or gaskets leaking. Loose or improperly torqued fasteners.	2. Replace all worn or damaged seals and gaskets. Make sure fasteners are tightened securely. Use appropriate torque values and sequences when necessary.
3. Piston blowby or leaky valves. (Confirm by inspecting components.)	3. Recondition piston, rings, cylinder bore, valves, and valve guides.
4. Restricted exhaust.	4. Replace restricted muffler/exhaust system.

MAGNUM

Single Cylinder Engine
Service Manual
Models M8, M10, M12
M14, M16
TP-2203-A 3/86

KOHLER
engines

AIR CLEANER

Magnum engines are equipped with a high-density paper air cleaner element. Some specifications are also equipped with an oiled foam precleaner which surrounds the paper element. Refer to Figures 5-1, 5-2, and 5-3.

DISASSEMBLY

1. Remove the wing nut and air cleaner cover.
2. Remove the precleaner (if so equipped), element cover nut, element cover, paper element, and seal.
3. Remove the base screws, air cleaner base, gasket, and breather hose.

5

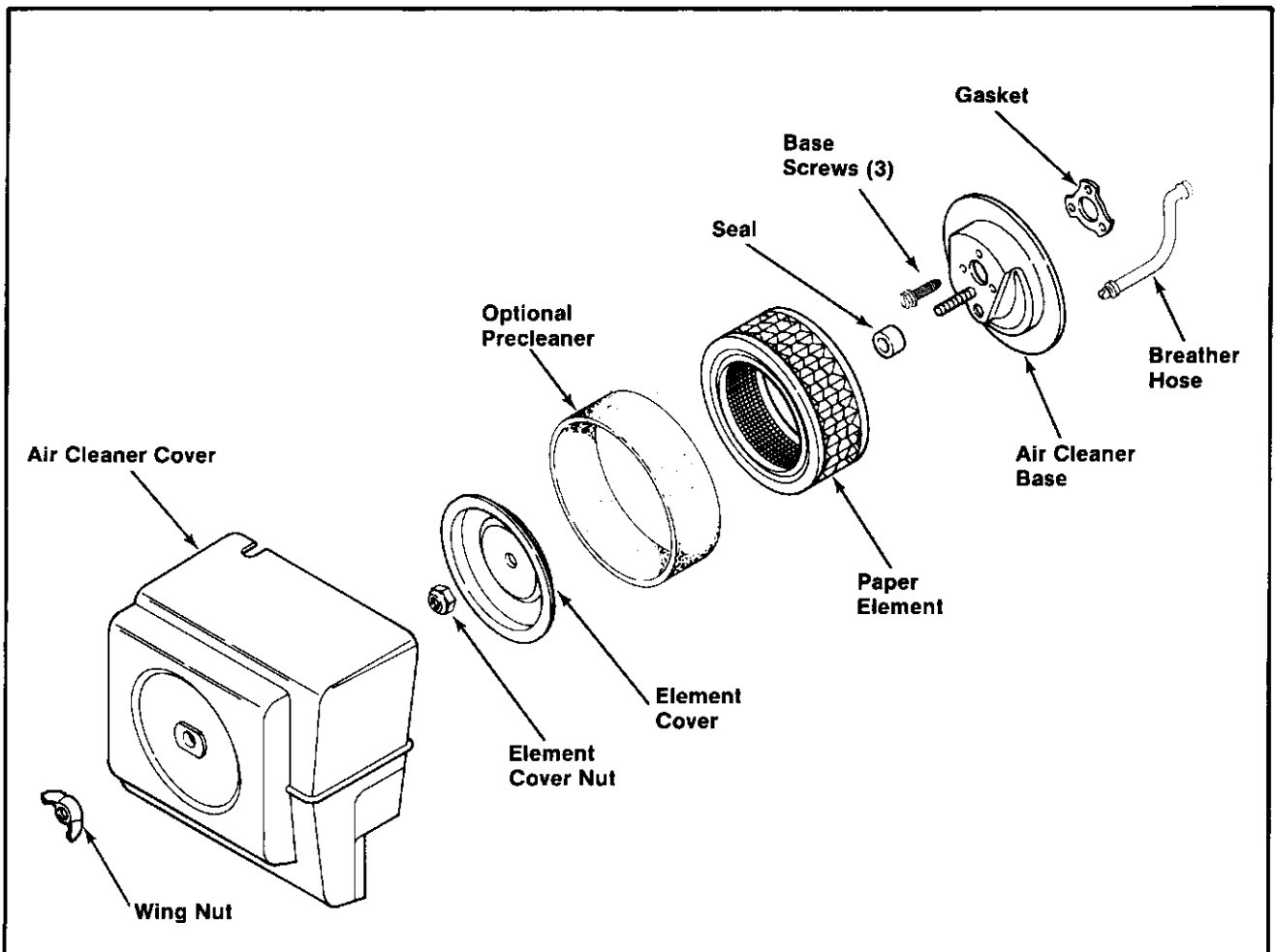

Figure 5-1. Air Cleaner Assembly - Exploded View.

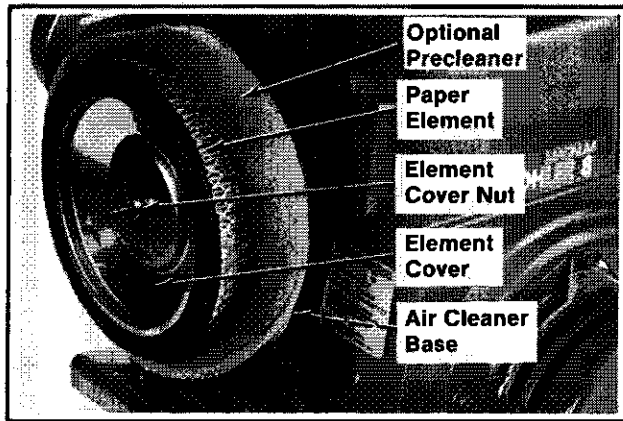

Figure 5-2. Air Cleaner Components.

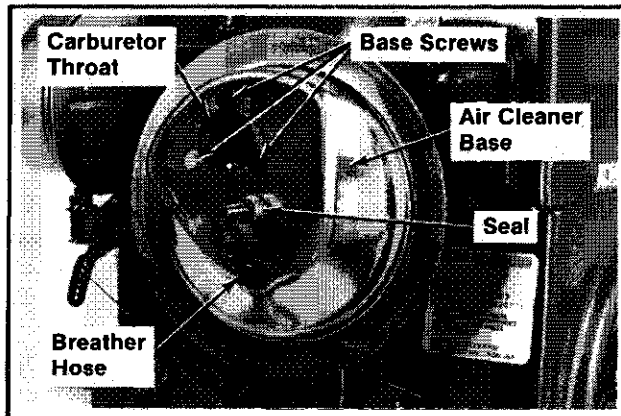

Figure 5-3. Air Cleaner Components.

REASSEMBLY

1. Install the breather hose, gasket, air cleaner base, and screws.

CAUTION: Make sure breather hose seals tightly in air cleaner base and breather cover to prevent unfiltered air from entering engine.

2. Install the seal, paper element, element cover, and element cover nut. Tighten nut to **50 in. lbs.** torque.
3. If so equipped, install the precleaner (cleaned and oiled) over the paper element.
4. Install the air cleaner cover and wing nut. Tighten wing nut until it is snug against cover—do not overtighten.

SERVICE

Precleaner

If so equipped, wash and reoil the precleaner every 25 operating hours (more often under extremely dusty or dirty conditions).

2. Rinse the precleaner thoroughly until all traces of detergent are eliminated. Squeeze out excess water (do not wring). Allow precleaner to air dry.
3. Saturate the precleaner in clean, fresh engine oil. Squeeze out excess oil.
4. Reinstall the precleaner over paper element.

Paper Element

Every 100 operating hours (more often under extremely dusty or dirty conditions) check the paper element. Replace the element as follows:

1. Remove the precleaner (if so equipped), element cover nut, element cover, and paper element.
2. Replace a dirty, bent or damaged element with a new genuine Kohler element. Handle new elements carefully; do not use if surfaces are bent or damaged.

CAUTION: Do not wash the paper element or use compressed air as this will damage the element.

3. Reinstall the paper element, element cover, and element cover nut. Make sure nut is tightened securely and element is sealed tightly against the element cover and air cleaner base.
4. Install the precleaner (cleaned and oiled) over the paper element.
5. Install the air cleaner cover and wing nut. Tighten wing nut until it is snug against cover—do not overtighten.

Inspect Air Cleaner Components

Whenever the air cleaner cover is removed, or servicing the element or precleaner, check the following components:

- **Air Cleaner Base**—Make sure it is secured tightly to carburetor and is not bent or damaged.
- **Element Cover and Element Cover Nut**—Make sure element cover is not bent or damaged. Make sure element cover nut is secured tightly to seal element between air cleaner base and element cover. Tighten nut to **50 in. lbs.** torque.
- **Breather Tube**—Make sure it is sealed tightly in air cleaner base and breather cover.

CAUTION: Damaged, worn, or loose air cleaner components could allow unfiltered air into the engine causing premature wear and failure. Replace all damaged or worn components.

MAGNUM

Single Cylinder Engine
Service Manual
Models M8, M10, M12
M14, M16
TP-2203-A 3/86

KOHLER
engines

FUEL SYSTEM AND GOVERNOR

FUEL SYSTEM

The typical fuel system and related components include the fuel tank with vented cap, shutoff valve with screen, in-line fuel filter, fuel pump, carburetor, and interconnecting fuel line. Refer to Figure 6A-1.

Operation

The fuel from the tank is moved through the screen and shutoff valve, in-line filter, and fuel lines by the fuel pump. Fuel then enters the carburetor float bowl and is moved into the carburetor body where it is mixed with air. This fuel-air mixture is then burned in the engine combustion chamber.

Troubleshooting

Use the following procedure to check if fuel is reaching the combustion chamber.

WARNING: Explosive Fuel!



Gasoline is extremely flammable and its vapors can explode if ignited. Before troubleshooting the fuel system, make sure there are no sources of heat, flames, or sparks nearby as these can ignite gasoline vapors. Disconnect and ground the spark plug lead to eliminate the possibility of sparks from the ignition system.

6

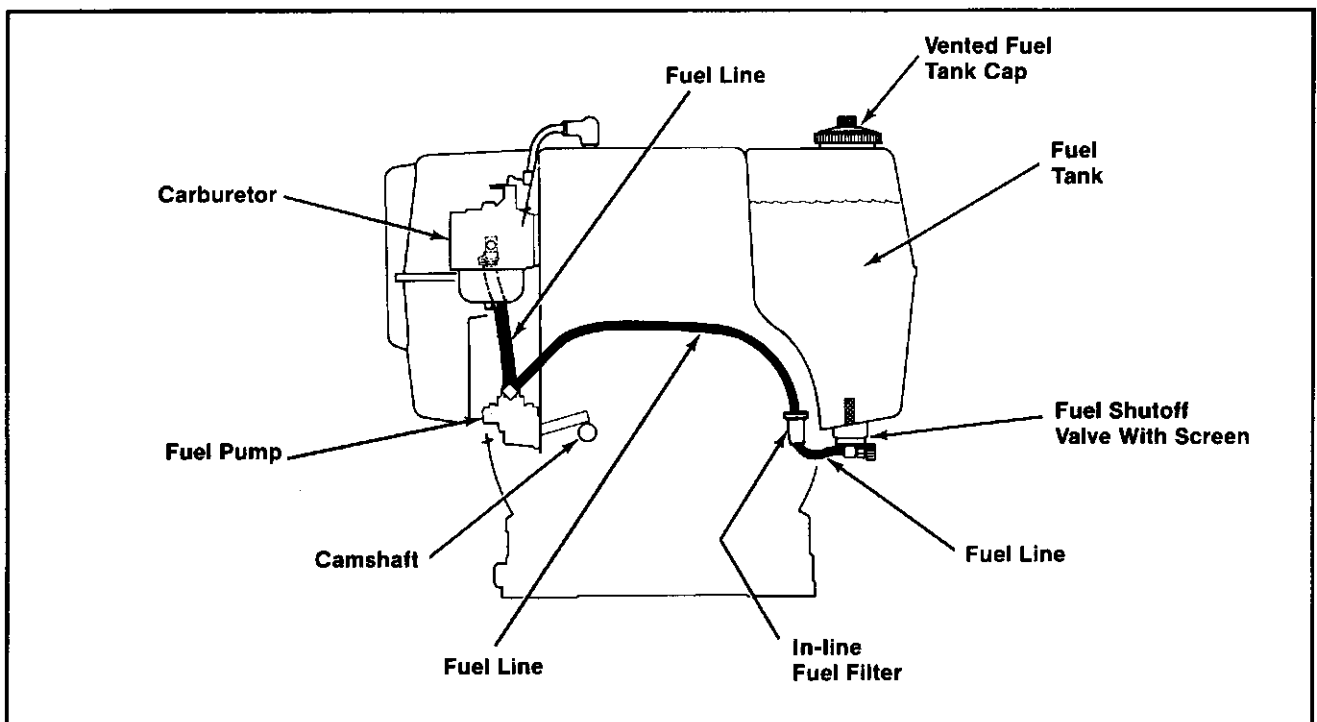

Figure 6A-1. Typical Fuel System.

Test	Conclusion
<p>1. Check for the following:</p> <p>A. Make sure the fuel tank contains fuel.</p> <p>B. Make sure the vent in fuel cap is open.</p> <p>C. Make sure the fuel shutoff valve is open.</p>	
<p>2. Check for fuel in the combustion chamber.</p> <p>A. Disconnect the spark plug lead.</p> <p>B. Close the choke on carburetor.</p> <p>C. Crank the engine several times.</p> <p>D. Remove the spark plug and check for fuel at tip.</p>	<p>2. If there is fuel at tip of spark plug, fuel is reaching the combustion chamber.</p> <p>If there is no fuel at tip of spark plug, check for fuel flow from the fuel tank. (Test 3).</p>
<p>3. Check for fuel flow from the fuel tank to fuel pump.</p> <p>A. Remove the fuel line from inlet fitting of fuel pump.</p> <p>B. Hold the line below the bottom of tank. Open the shutoff valve and observe flow.</p>	<p>3. If fuel does flow from line, check for faulty fuel pump. (Test 4).</p> <p>If fuel does not flow from line, check for clogged fuel tank vent, shutoff valve screen, and fuel lines.</p>
<p>4. Check operation of fuel pump.</p> <p>A. Remove the fuel line from inlet fitting of carburetor.</p> <p>B. Crank the engine several times and observe flow.</p>	<p>4. If fuel does not flow from line, check for clogged fuel line. If line is unobstructed, fuel pump is faulty and must be replaced.</p> <p>If fuel does flow from fuel line, the carburetor probably is faulty. Refer to the "Carburetor" portion of this section.</p>

FUEL TANK

The fuel tank is made of a tough, impact resistant material. If the tank does become cracked or damaged, it is not repairable and must be replaced. Refer to Figure 6A-2.

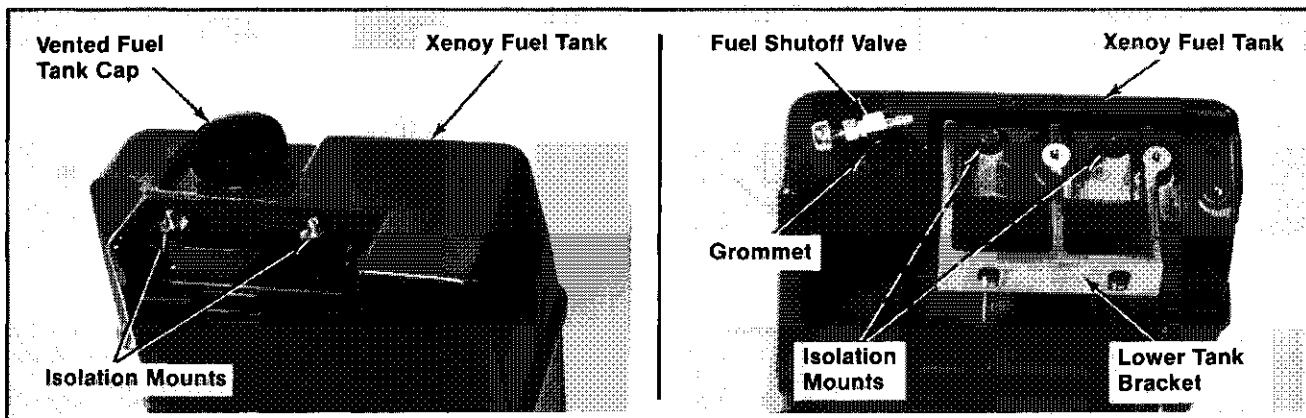

Figure 6A-2. Fuel Tank.

Fuel Shutoff Valve

Some engines are equipped with a fuel shutoff valve with a wire mesh screen. On engines without the shutoff valve, a straight outlet fitting is installed. The shutoff valve or outlet fitting are installed into the bottom of the fuel tank with a rubber grommet.

REMOVAL

1. Grasp the shutoff valve or outlet fitting and pull from tank using a side-to-side twisting motion.
2. Remove the grommet from tank, or from shutoff valve or outlet fitting.

INSTALLATION

1. Install the grommet into bottom of fuel tank.
2. Press the shutoff valve or outlet fitting securely into the grommet.

Isolation Mounts

Isolation mounts are used on model M8 engines with top mounted tank, and on Models M10, M12, M14, and M16 engines with side mounted tanks. Install isolation mounts into fuel tank **hand tight**.

Refer to the "Disassembly" and "Reassembly" sections for complete fuel tank removal and installation procedures.

FUEL FILTER

Some engines are equipped with an in-line fuel filter. Visually inspect the filter periodically. Replace when dirty with a genuine Kohler filter. Refer to Figure 6A-3.



Figure 6A-3. In-line Fuel Filter.

FUEL PUMP

Most Magnum engines are equipped with a mechanically operated fuel pump. On applications using a gravity feed fuel system, the fuel pump is not used and the pump mounting pad on the crankcase is covered.

The fuel pump body is constructed of a nylon material. The nylon body insulates the fuel from the hot engine crankcase and prevents fuel from vaporizing inside the pump.

Operation

The mechanical fuel pump is operated by a lever which rides on the engine camshaft. The lever transmits a pumping action to the diaphragm inside the pump body. This pumping action draws fuel in through the inlet check valve on the downward stroke of diaphragm. On the upward stroke of the diaphragm, the fuel is forced out through the outlet check valve. Refer to Figure 6A-4.

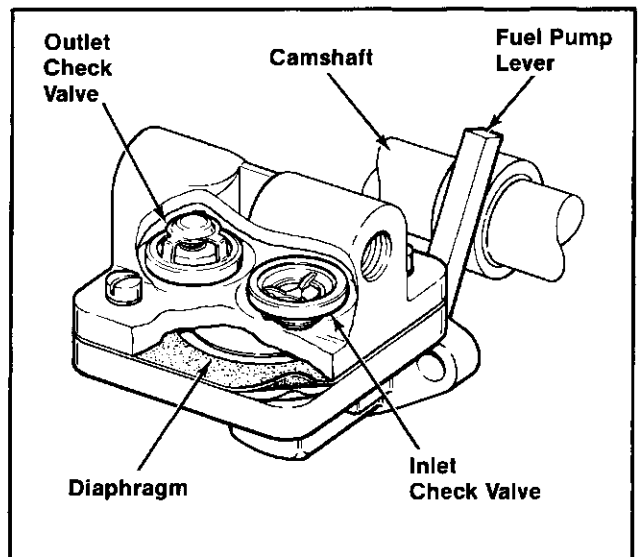

Figure 6A-4. Mechanical Fuel Pump.

Removal

1. Disconnect the fuel lines from the inlet and outlet fittings of pump.
2. Remove the fillister head sems screws, plain washers, fuel pump, and gasket.
3. If necessary, remove the fittings from pump body.

Repair

Nylon-bodied fuel pumps are not serviceable and must be replaced when faulty. Replacement pumps are available in kits which include the pump, mounting gasket, and plain washers.

Installation (Refer to Figure 6A-5.)

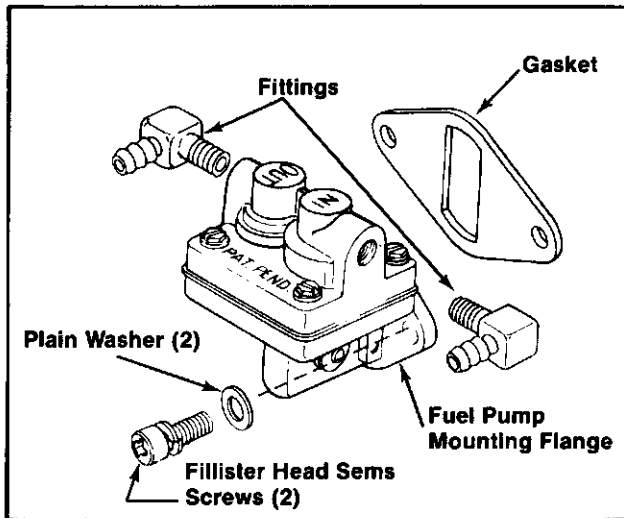

Figure 6A-5. Installing Fuel Pump.

1. **Fittings**—Apply a small amount of Permatex® Aviation Perm-A-Gasket (or equivalent) gasoline resistant thread sealant to fittings. Turn fittings into pump **6 full turns**; continue turning fittings in same direction until desired position is reached.

2. Install new gasket, fuel pump, plain washers, and fillister head sems screws.

CAUTION: Make sure the fuel pump lever is positioned above the camshaft. Damage to the fuel pump, and subsequent severe engine damage could result if the lever is positioned below the camshaft.

Make sure the plain washers are installed next to the mounting flange to prevent damage from the lockwasher.

Torque screws to **40/45 in. lb.**

3. Connect fuel lines to inlet and outlet fittings.

CARBURETOR

This subsection covers the adjustment, disassembly, cleaning, inspection, repair, and reassembly of **Kohler-built, side draft, adjustable jet carburetors**.

WARNING: Explosive Fuel!



Gasoline may be present in the carburetor and fuel system. Gasoline is extremely flammable and its vapors can explode if ignited. Keep sparks, open flame, and other sources of ignition away from engine. Wipe up spilled fuel immediately.

Adjustment

The carburetor is designed to deliver the correct fuel/air mixture to the engine under all operating conditions. Carburetors are set at the factory and normally do not need adjustment. If the engine exhibits conditions like those found in the table below, it may be necessary to adjust the carburetor.

Turning the adjusting needles **in** (clockwise) decreases the supply of fuel to the carburetor. This gives a **leaner** fuel/air mixture. Turning the adjusting needles **out** (counterclockwise) increases the supply of fuel to the carburetor. This gives a **richer** fuel/air mixture. Refer to Figures 6A-6 and 6A-7.

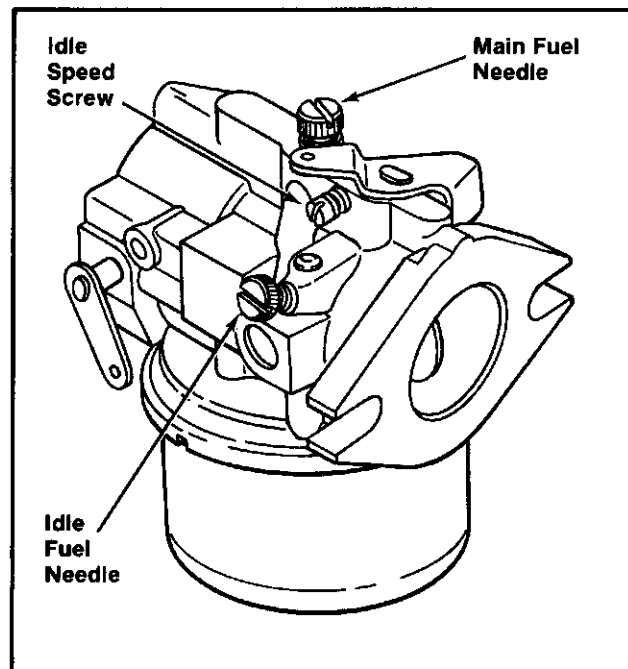

Figure 6A-6. Kohler-Built Adjustable Jet Carburetor.

CAUTION: Incorrect settings can cause a fouled spark plug, overheating, excessive valve wear, and other problems. To ensure correct settings, make sure the following adjustment procedures are used.

Make carburetor adjustments after the engine has warmed.

Condition	Possible Cause/Probable Solution
1. Black sooty exhaust smoke*, engine sluggish.	1. Main fuel mixture too rich. Turn main fuel adjusting needle in (clockwise).
2. Engine misses and backfires at high speed.	2. Main fuel mixture too lean. Turn main fuel adjusting needle out (counterclockwise).
3. Engine starts and then stops under cold weather conditions.	3. Main fuel mixture too lean. Turn main fuel adjusting needle out (counterclockwise).
4. Engine runs roughly or stalls at idle speed.	4. Idle speed too low or improper idle fuel mixture. Turn idle speed adjusting screw, then idle fuel adjusting needle.

**If black exhaust smoke is noted, check the air cleaner first. An apparent "overrich" mixture can actually be caused by a clogged air cleaner element. If after element is replaced, black smoke or other problems continue, adjust the carburetor immediately.*

1. Stop the engine. Turn the main fuel and idle fuel adjusting needles **in** (clockwise) until they bottom *lightly*.

CAUTION: The ends of the main fuel and idle fuel adjusting needles are tapered to critical dimensions. Damage to needles and seats will result if the needles are forced.

2. **Preliminary Settings:** Turn the main fuel and idle fuel adjusting needles **out** (counterclockwise) from lightly bottomed as follows:

Engine Model	Main Fuel	Idle Fuel
M8 (8 hp)	2 turns	1-1/4 turns
M10 (10 hp)	1-1/2 turns	2-1/2 turns
M12 (12 hp)	1-1/2 turns	2-1/2 turns
M14 (14 hp)	2-1/2 turns	2-1/2 turns
M16 (16 hp)	2-1/2 turns	2-1/2 turns

3. Start the engine and run at half-throttle for 5-10 minutes to warm up. Engine must be warm before making final settings (steps 4-6).
4. **Final Setting - Main Fuel:** Place throttle in wide open position; and if possible, place engine under load. Turn main fuel adjusting needle **out** (counterclockwise) from preliminary setting until the engine speed decreases (rich). Note the position of the needle.

Now turn the adjusting needle **in** (clockwise). The engine speed may increase, then it will decrease as the needle is turned in (lean). Note the position of the needle.

Set the adjusting needle **midway** between the rich and lean settings noted. Refer to Figure 6A-7.

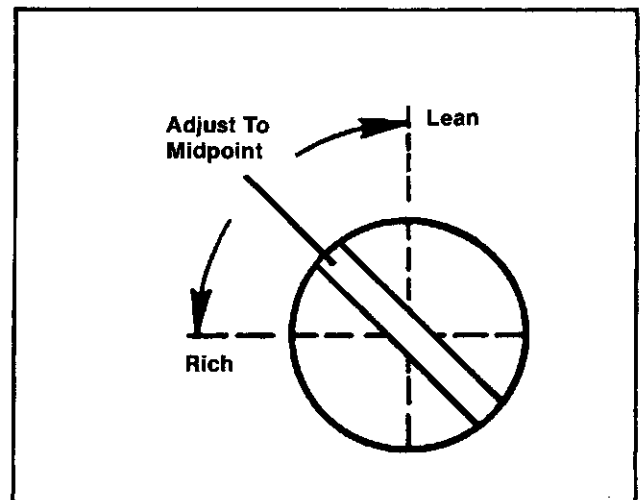

Figure 6A-7. Carburetor Adjustment.

5. **Final Setting - Idle Fuel:** Place throttle into idle or slow position. Set idle fuel adjusting needle using the same procedure as in step 4.

NOTE: To ensure best results when setting idle fuel mixture, the idle speed must not exceed 1500 RPM. Typical idle speed is 1200* RPM. See step 6.

6. **Idle Speed Setting:** Place throttle into idle or slow position. Set idle speed to 1200* RPM (\pm 75 RPM) by turning the idle speed adjusting screw in or out.

*NOTE: The actual idle speed depends on the application. Refer to the equipment manufacturer's instructions for specific idle speed settings.

Disassembly
(Refer to Figure 6A-8.)

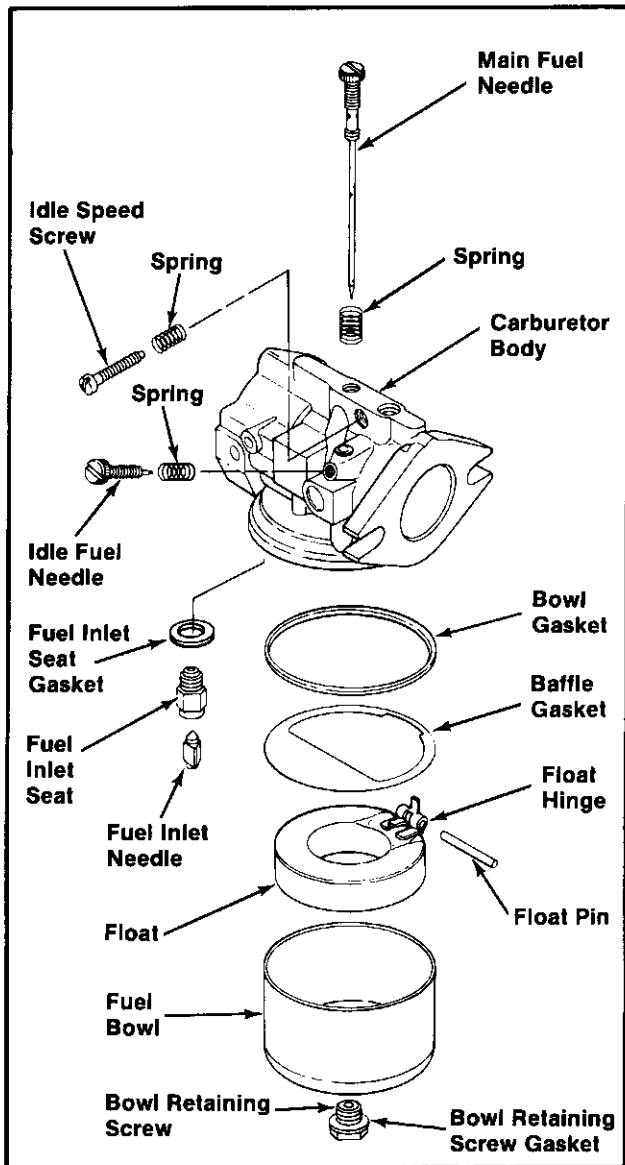

Figure 6A-8. Kohler-Built Adjustable Jet Carburetor - Exploded View.

1. Remove the bowl retaining screw, retaining screw gasket, and fuel bowl.
2. Remove the float pin, float, fuel inlet needle, baffle gasket, and bowl gasket.
3. Remove the fuel inlet seat and inlet seat gasket. Remove the idle fuel and main fuel adjusting needles and springs. Remove the idle speed adjusting screw and spring.
4. Further disassembly to remove the throttle and choke shafts is recommended only if these parts are to be replaced. Refer to "Throttle And Choke Shaft Replacement."

Cleaning

WARNING: Flammable Solvents!



Carburetor cleaners and solvents are extremely flammable. Keep sparks, flames, and other sources of ignition away from area. Follow the cleaner manufacturer's warnings and instructions on its proper and safe use. Never use gasoline as a cleaning agent.

All parts should be carefully cleaned using a carburetor cleaner (such as acetone). Be sure all gum deposits are removed from the following areas:

- **Carburetor body and bore;** especially the areas where throttle plate, choke plate, and shafts are seated.
- **Float and float hinge.**
- **Fuel bowl.**
- **Idle fuel and "off-idle" ports in carburetor bore, ports in main fuel adjusting needle, and main fuel seat.** (Note: these areas can be cleaned using piece of fine wire in addition to cleaners. Be careful not to enlarge the ports, or break the cleaning wire within ports.)

Blow out all passages with compressed air.

CAUTION: Do not submerge carburetor in cleaner or solvent when fiber and rubber seals are installed. The cleaner may damage these seals.

Inspection

Carefully inspect all components and replace those that are worn or damaged.

- Inspect the carburetor body for cracks, holes, and other wear or damage.
- Inspect the float for dents or holes. Check the float hinge for wear, and missing or damaged float tabs.
- Inspect the inlet needle and seat for wear or grooves.
- Inspect the tips of the main fuel and idle fuel adjusting needles for wear or grooves.
- Inspect the throttle and choke shaft and plate assemblies for wear or excessive play.

Repair

Always use new gaskets when servicing and re-installing carburetors. Several repair kits are available which include the gaskets and other components; these kits are described below. Always refer to the Parts Manual for the engine being serviced to ensure the correct carburetor repair kits and replacement parts are ordered.

Float Repair Kit No. 25 757 03 Contains:

Qty.	Description
1	Float Assembly
1	Baffle Gasket

Carburetor Repair Kits No. 25 757 01 And No. 25 757 02 Contain:

Qty.	Description
1	Bowl Retaining Screw Gasket
1	Bowl Gasket
1	Baffle Gasket
1	Fuel Inlet Seat Gasket
1	Fuel Inlet Seat
1	Fuel Inlet Needle
1	Float Pin

Throttle And Choke Shaft Replacement

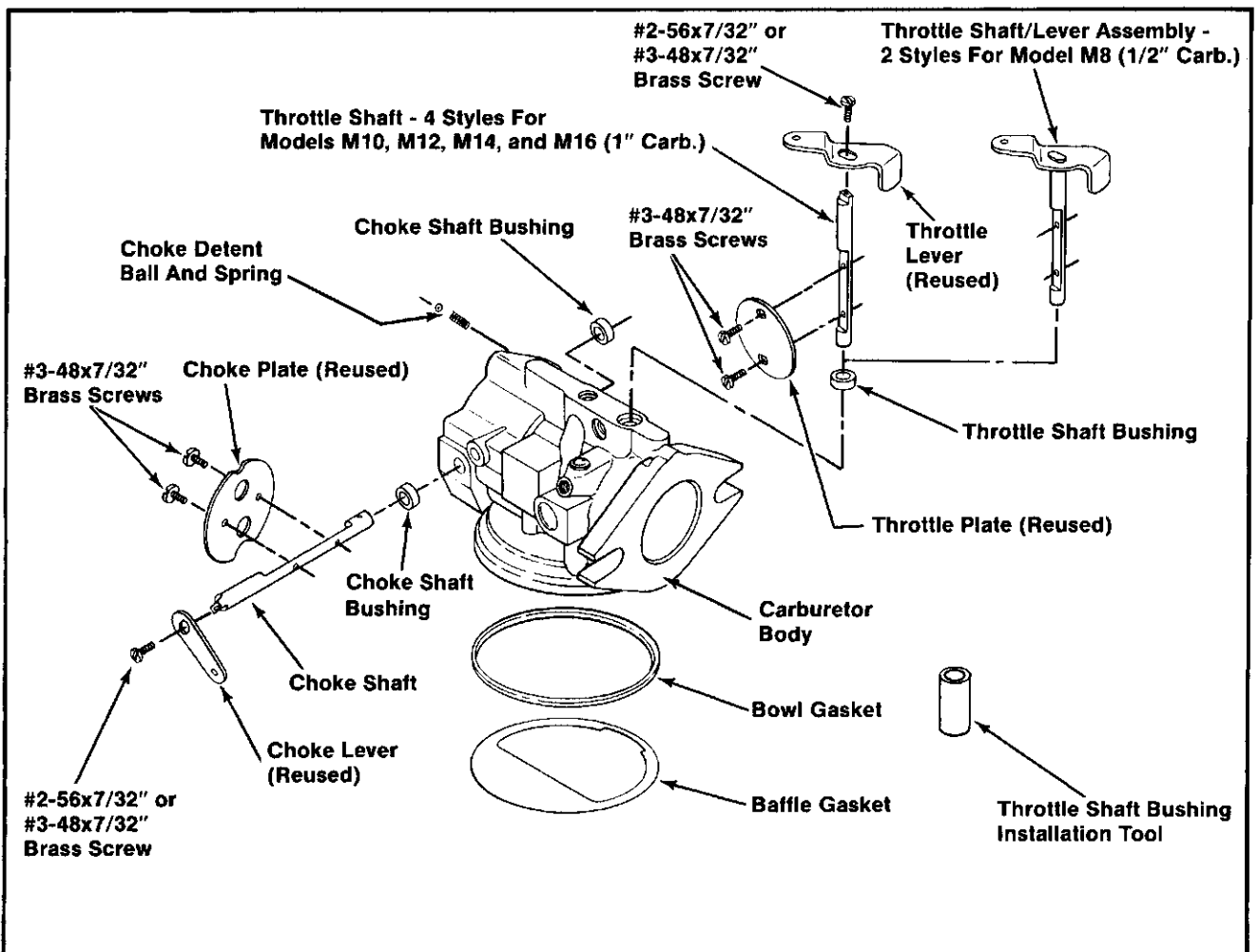

Figure 6A-9. Throttle And Choke Shaft Replacement Kits.

Two kits are available for replacement of the throttle and choke shafts in Kohler-built carburetors. Refer to Figure 6A-9.

Kit no. 25 757 04 services the Model M8 carburetor with 1/2" venturi.

Kit no. 25 757 05 services Models M10, M12, M14, and M16 carburetors with 1" venturi.

For Model M8 (1/2" Carb.)—

Kit No. 25 757 04 Contains:

Qty.	Description
1	Choke Detent Ball
1	Choke Detent Spring
2	Choke Shaft Bushing
5	Brass Screw, #3-48 x 7/32"
2	Throttle Shaft Assembly
1	Throttle Shaft Bushing
1	Baffle Gasket
1	Bowl Gasket
1	Choke Shaft
2	Brass Screw, #2-56 x 7/32"
1	Throttle Shaft Bushing Installation Tool
1	LOCTITE® #609, Tube

For Models M10, M12, M14, and M16 (1" Carb.)—

Kit No. 25 757 05 Contains:

Qty.	Description
1	Choke Detent Ball
1	Choke Detent Spring
2	Choke Shaft Bushing
6	Brass Screw, #3-48 x 7/32"
4	Throttle Shaft
1	Throttle Shaft Bushing
1	Baffle Gasket
1	Bowl Gasket
1	Choke Shaft
2	Brass Screw, #2-56 x 7/32"
1	Throttle Shaft Bushing Installation Tool
1	LOCTITE® #609, Tube

To Replace Throttle And Choke Shafts—

WARNING: Prevent Eye Injury!



Suitable eye protection (safety glasses, goggles, or face hood) should be worn for any procedure involving the use of compressed air, punches, hammers, chisels, drills, or grinding tools.

Disassemble Carburetor

Refer to "Disassembly" steps 1-3.

Remove Choke Plate and Choke Shaft; Transfer Choke Lever

1. To ensure correct reassembly, mark choke plate and carburetor body with a marking pen. Also take note of choke plate position in bore, and choke lever position.
2. *Carefully and slowly* remove the screws securing choke plate to choke shaft. Remove and save the choke plate as it will be reused.
3. File off any burrs which may have been left on choke shaft when screws were removed. Place carburetor on work bench with choke side down. Remove choke shaft; the detent ball and spring will drop out.
4. Note the position of the choke lever with respect to the cutout portion of choke shaft.
5. Carefully grind or file away the riveted portion of shaft. Remove and save choke lever; discard old choke shaft.
6. Install choke lever to new choke shaft from kit. Make sure lever is installed correctly as noted in step 4. Secure lever to choke shaft as follows:

*For Model M8 (1/2" Carb.)—*Apply Loctite to threads of (1) #2-56x7/32" brass screw; secure lever to shaft.

*For Models M10, M12, M14, and M16 (1" Carb.)—*Apply Loctite to threads of (1) #3-48x7/32" brass screw; secure lever to shaft.

Remove Throttle Plate And Throttle Shaft; Transfer Throttle Lever

1. To ensure correct reassembly, mark throttle plate and carburetor body with a marking pen. Also take note of throttle plate position in bore, and throttle lever position.
2. *Carefully and slowly* remove the screws securing the throttle plate to throttle shaft. Remove and save the throttle plate as it will be reused.
3. File off any burrs which may have been left on throttle shaft when screws were removed.

CAUTION: Failure to remove burrs from the throttle shaft may cause permanent damage to carburetor body when shaft is removed.

4. Remove the throttle shaft from carburetor body. Remove and discard the foam rubber dust seal from throttle shaft.
5. Remove/transfer throttle lever as follows:

For Model M8 (1/2" Carb.)—Carefully grind or file away the riveted portion of throttle shaft. Save the throttle shaft as it will be used to install the new throttle shaft bushing. Discard the throttle lever.

For Models M10, M12, M14, and M16 (1" Carb.)—

- a. Note the position of the throttle lever with respect to the cutout portion of throttle shaft.
- b. Carefully grind or file away the riveted portion of shaft; remove throttle lever.
- c. Carefully compare the old shaft to the new shafts from kit. Select the appropriate new shaft and discard the old shaft.
- d. Install throttle lever to throttle shaft. Make sure lever is installed correctly as noted in step a.
- e. Apply Loctite to threads of (1) #2-56x7/32" brass screw (use #3-48x7/32" screw with 2-49/64" shaft); secure lever to shaft.

Drill Choke Shaft Bores Using A Drill Press

1. Mount the carburetor body in a drill press vise. Keep vise slightly loose.
2. Install a drill of the following specified size in drill press chuck. Lower drill (not rotating) through both choke shaft bores; then tighten vise. This ensures the carburetor body and drill are perpendicular and in correct alignment.

For Model M8 (1/2" Carb.)—
Use a 7/32" dia. drill.

For Models M10, M12, M14, and M16 (1" Carb.)—Use a 1/4" dia. drill.

Refer to Figure 6A-10.

3. Install a 19/64" dia. drill in chuck. Set drill press speed to a low speed suitable for aluminum. Feed drill slowly to obtain a good finish to holes.
4. Ream the choke shaft bores to a final size of 5/16". For best results use a piloted 5/16" reamer.
5. Blow out all metal chips using compressed air. Thoroughly clean the carburetor body in a carburetor cleaner.

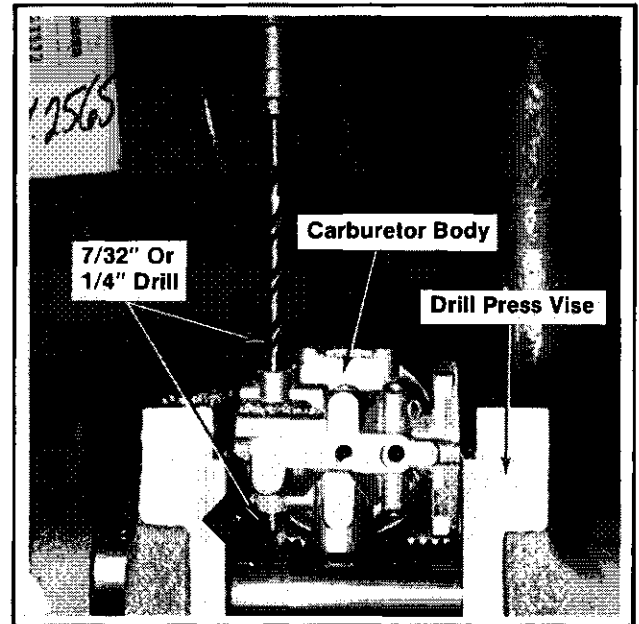

Figure 6A-10. Aligning/Drilling Carburetor Body.

Install Choke Shaft Bushings

1. Install screws into the tapped holes that enter the choke shaft bores until the screws bottom lightly. Refer to Figure 6A-11.

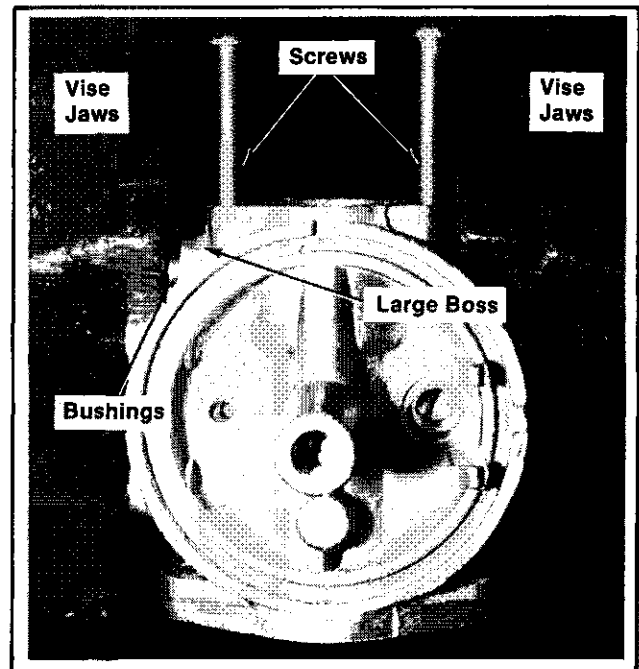

Figure 6A-11. Installing Choke Shaft Bushings.

2. Coat the outside surface of choke shaft bushings with Loctite from kit. Carefully press bushings into carburetor body using a smooth-jawed vise. Stop pressing when bushings bottom against screws.

For Model M8 (1/2" Carb.)—Make sure the bushing is pressed below the surface of the large choke shaft boss until the bushing bottoms against screw.

3. Allow Loctite to "set" for 5-10 minutes then remove screws.
4. Install new choke shaft in bushings. Rotate shaft and check for binding.

CAUTION: If binding occurs, locate and correct the cause before proceeding. Use choke shaft to align bushings if necessary.

5. Remove choke shaft and allow Loctite to "set" for an additional 30 minutes before proceeding.
6. Wipe away all excess Loctite from bushings and choke shaft.

Install Throttle Shaft Bushing

1. Make sure the dust seal counterbore in carburetor body is thoroughly clean and free of chips and burrs.
2. Install a throttle shaft (without throttle lever) into carburetor body to use as a pilot:

For Model M8 (1/2" Carb.)—Use the old throttle shaft removed previously.

For Models M10, M12, M14, and M16 (1" Carb.)—Use one of the remaining new throttle shafts from kit.

3. Coat the outside surface of throttle shaft bushing with Loctite from kit. Slip bushing over shaft. Using installation tool from kit and vise, press bushing into counterbore until it bottoms in carburetor body. Refer to Figure 6A-12.
4. Allow Loctite to "set" for 5-10 minutes then remove throttle shaft.
5. Install new throttle shaft with lever into carburetor body. Rotate shaft and check for binding.

CAUTION: If binding occurs, locate cause and correct before proceeding. Use throttle shaft to align bushing is necessary.

6. Remove shaft and allow Loctite to "set" for an additional 30 minutes before proceeding.
7. Wipe away all excess Loctite from bushing and throttle shaft.

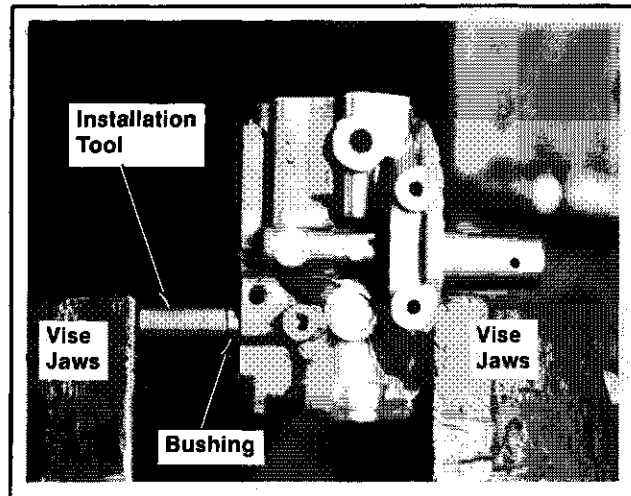

Figure 6A-12. Installing Throttle Shaft Bushings.

Install Detent Spring And Ball, Choke Shaft, And Choke Plate

1. Install new detent spring and ball into carburetor body in the side opposite choke lever.
2. Compress detent ball and spring and insert choke shaft through bushings. Make sure the choke lever is on the correct side of carburetor body. Refer to Figure 6A-13.

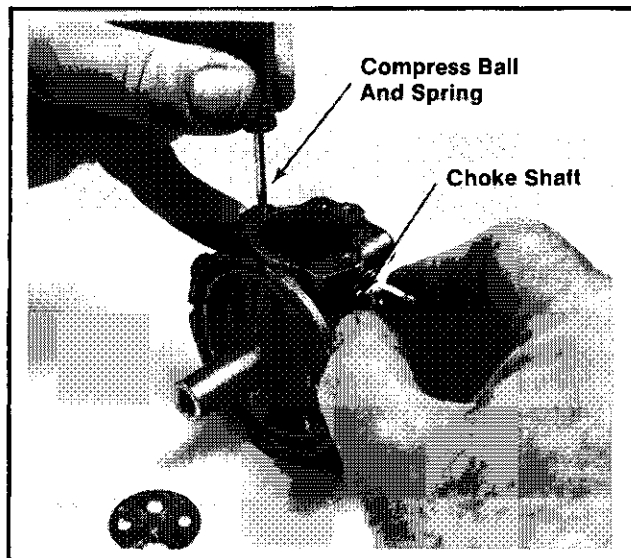

Figure 6A-13. Installing Choke Shaft.

3. Install choke plate to choke shaft. Make sure marks are aligned and plate is positioned properly in bore. Apply Loctite to threads of (2) #3-48x7/32" screws. Install screws so they are slightly loose.
4. Operate choke lever. Check for binding between choke plate and carburetor bore. Loosen screws and adjust plate as necessary; then tighten screws securely.

Install Throttle Shaft And Throttle Plate

1. Install throttle shaft into carburetor with cutout portion of shaft facing out.
2. Install throttle plate to throttle shaft. Make sure marks are aligned and plate is positioned properly in bore. Apply Loctite to threads of (2) #3-48x7/32" screws. Install screws so they are slightly loose.
3. Apply finger pressure to throttle shaft to keep it firmly seated against pivot in carburetor body. Rotate the throttle shaft until throttle plate fully closes the bore around its entire perimeter; then tighten screws.
4. Operate throttle lever and check for binding between throttle plate and carburetor bore. Loosen screws and adjust plate as necessary; then tighten screws securely.

Reassemble Carburetor

Refer to the following "Reassembly" portion of this section.

Reassembly

1. Install the fuel inlet seat gasket and fuel inlet seat into carburetor body. Torque seat to **35/45 in. lb.**
2. Install the fuel inlet needle into inlet seat. Install float and slide float pin through float hinge and float hinge towers on carburetor body.
3. **Set float level:** Invert carburetor so the float tab rests on the fuel inlet needle. There should be **11/64"** ($\pm 1/32"$) clearance between the machined surface of body and the free end of float. Bend the float tab with a small screwdriver to adjust. Refer to Figure 6A-14.

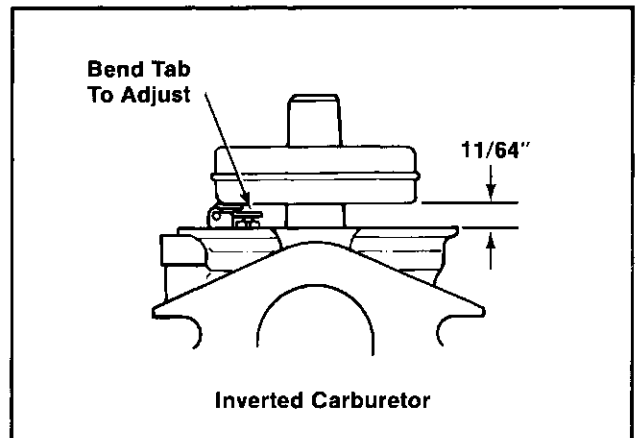

Figure 6A-14. Setting Float Level.

4. **Set float drop:** Turn the carburetor over to its normal operating position and allow float to drop to its lowest level. The float drop should be limited to **1-1/32"** between the machined surface of body and the bottom of the free end of float. Bend the float tab with a small screwdriver to adjust. Refer to Figure 6A-15.

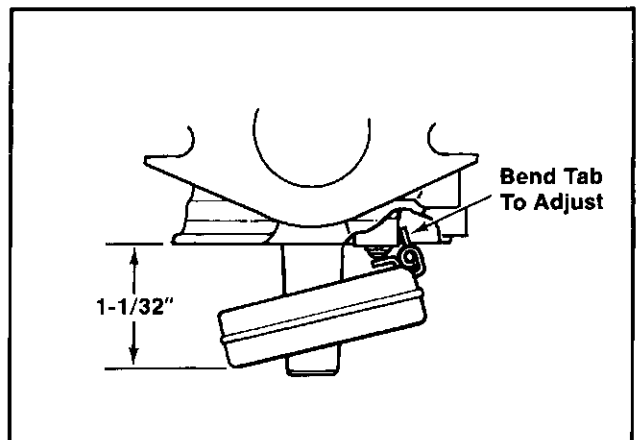

Figure 6A-15. Setting Float Drop.

5. **Check float-to-float hinge tower clearance:** Invert the carburetor so the float tab rests on the fuel inlet needle. Insert a **.010"** feeler gauge between float and float hinge towers. If the feeler gauge cannot be inserted, or there is interference between the float and towers, file the towers to obtain the proper clearance. Refer to Figure 6A-16.

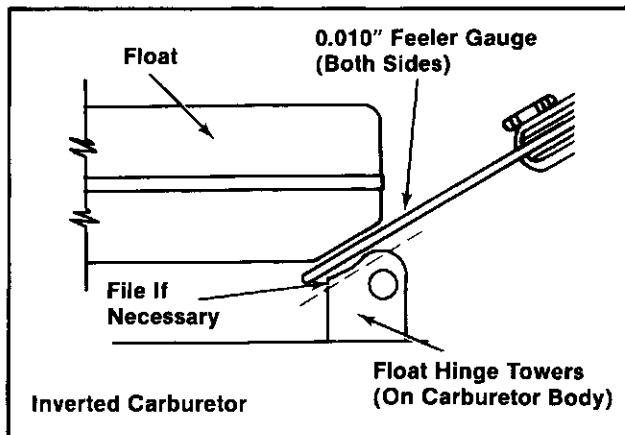

Figure 6A-16. Checking Float Clearance.

6. Install the bowl gasket and baffle gasket. Position baffle gasket so the inner edge is against the float hinge towers.
7. Install the fuel bowl so it is centered on the baffle gasket. Make sure the baffle gasket and bowl are positioned properly to ensure a good seal.

8. Install the bowl retaining screw gasket and bowl retaining screw. Torque screw to **50/60 in. lb.**

9. Install the idle speed adjusting screw and spring. Install the idle fuel and main fuel adjusting needles and springs. Turn the adjusting needles clockwise until they bottom *lightly*.

CAUTION: The ends of adjusting needles are tapered to critical dimensions. Damage to needles and seats will result if needles are forced.

10. Reinstall the carburetor to the engine using a new gasket.
11. Adjust the carburetor as outlined under the "Adjustment" portion of this section.

GOVERNOR

Magnum engines are equipped with a centrifugal flyweight mechanical governor. It is designed to hold the engine speed constant under changing load conditions. The governor gear/flyweight mechanism is mounted within the crankcase and is driven off the gear on the camshaft. Refer to Figure 6A-17.

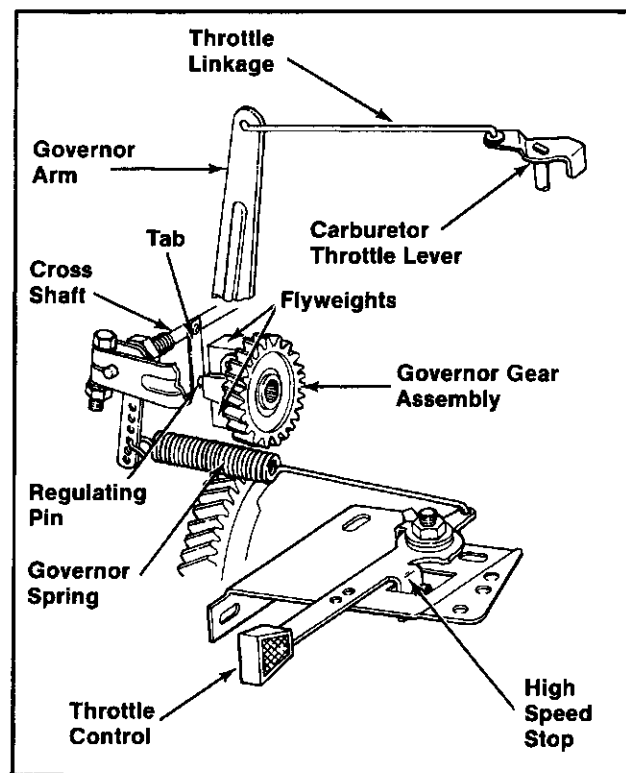

Figure 6A-17. Centrifugal Flyweight Mechanical Governor.

Operation

Centrifugal force acting on the rotating governor gear assembly causes the flyweights to move outward as speed increases and inward as speed decreases. As the flyweights move outward they force the regulating pin of the assembly to move outward. The regulating pin contacts the tab on the cross shaft, causing the shaft to rotate with changing speed. One end of the cross shaft protrudes through the side of the crankcase. Through external linkage attached to the cross shaft, the rotating action is transmitted to the throttle plate of carburetor.

When the engine is at rest and the throttle is in the "fast" position, the tension of the governor spring holds the throttle valve open. When the engine is operating (governor gear assembly is rotating), the force applied by the regulating pin against the cross shaft tends to close the throttle valve. The governor spring tension and the force applied by the regulating pin are in "equilibrium" during operation, holding the engine speed constant.

When a load is applied and the engine speed (and governor speed) decreases, the governor spring tension moves the governor arm to open the throttle plate wider. This admits more fuel and restores engine speed. (This action takes place

very rapidly, so a reduction in speed is hardly noticed.) As the speed reaches the governed setting, the governor spring tension and the force applied by the regulating pin will again be in equilibrium. This maintains engine speed at a relatively constant level.

Governed speed may be at a fixed point as on constant speed applications, or variable as determined by a throttle control lever.

Adjustment

WARNING: Overspeed Is Hazardous!



The maximum allowable speed for these engines is 3600 RPM, no load. Never tamper with the governor setting to increase the maximum speed. Severe personal injury and damage to the engine or equipment can result if operated at speeds above maximum.

INITIAL ADJUSTMENT

Make this initial adjustment whenever the governor arm is loosened or removed from cross shaft. Make sure the throttle linkage is connected to governor arm and throttle lever on carburetor to ensure proper setting. Refer to Figure 6A-18.

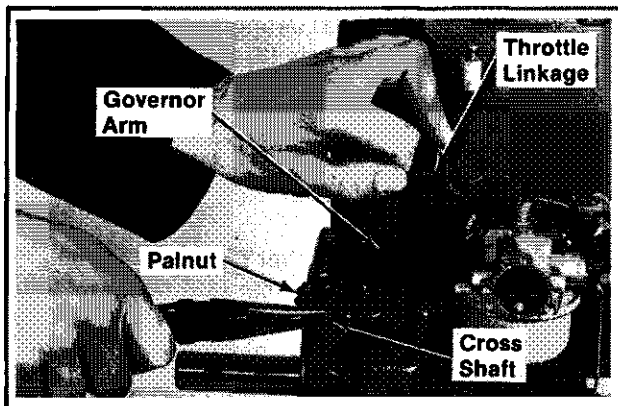

Figure 6A-18. Initial Governor Adjustment.

1. Pull the governor arm away from the carburetor as far as it will go.
2. Grasp the end of cross shaft with pliers and turn counterclockwise as far as it will go.
3. Tighten the palnut on governor arm to 15 in. lb. torque.

NOTE: On Model M8—Make sure there is at least 1/16" clearance between governor arm and cross shaft bushing nut to prevent interference.

On Models M10, M12, M14, and M16—Make sure there is at least 1/16" clearance between governor arm and upper left cam gear cover fastener to prevent interference. Refer to Figure 6A-19.

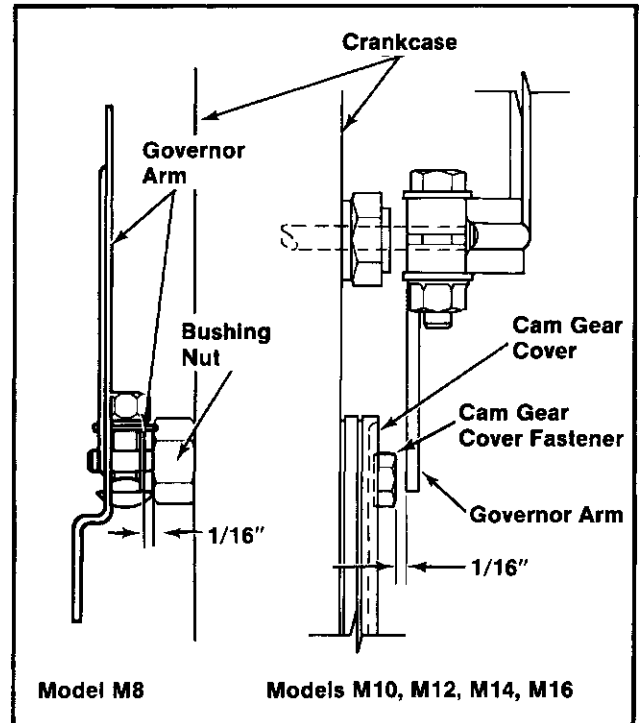

Figure 6A-19. Governor Arm Clearance.

HIGH SPEED ADJUSTMENT

The maximum allowable speed is 3600 RPM, no load. The actual high speed setting depends on the application. Refer to the equipment manufacturer's instructions for specific high speed settings. Check the operating speed with a tachometer; do not exceed the maximum. To adjust high speed stop:

1. Loosen the lock nut on high speed adjusting screw. Refer to Figures 6A-20 and 6A-21.

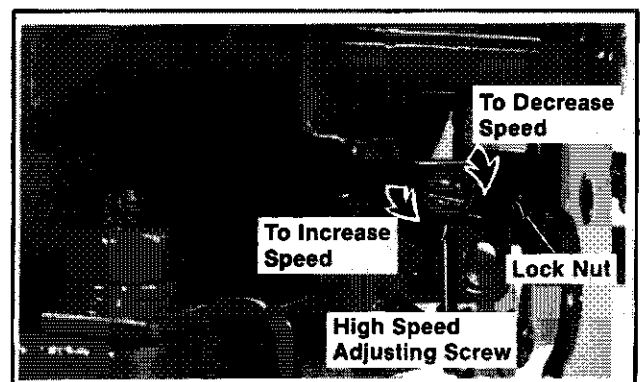

Figure 6A-20. High Speed Adjusting Screw - Model M8.

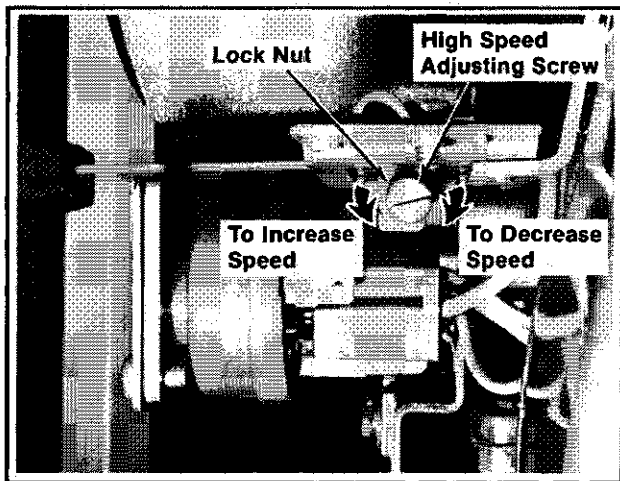

Figure 6A-21. High Speed Adjusting Screw - Models M10, M12, M14, And M16.

2. Turn the adjusting screw in or out until desired speed is reached. Tighten the lock nut.
3. Recheck the speed with the tachometer; readjust if necessary.

SENSITIVITY ADJUSTMENT

Governor sensitivity is adjusted by repositioning the governor spring in the holes in governor arm. If set too sensitive, speed surging will occur with a change in load. If a big drop in speed occurs when normal load is applied, the governor should be set for greater sensitivity.

The standard spring position on Model M8 engines is in the **third** hole from the cross shaft. On Model M10, M12, M14, and M16 engines, the standard position is the **sixth** hole from cross shaft. The position can vary, depending on the engine application. Therefore, make a note of (or mark) the spring position before removing it from the governor arm. Refer to Figure 6A-22.

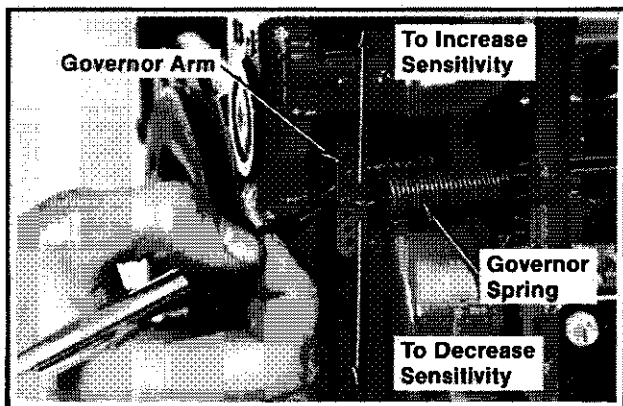

Figure 6A-22. Governor Sensitivity Adjustment.

To increase sensitivity, increase the governor spring tension by moving the spring towards the cross shaft.

To decrease sensitivity, and allow broader control, decrease spring tension by moving the spring away from the cross shaft.

ENGINE MOUNTED THROTTLE AND CHOKE CONTROLS

On Model M8

(Refer to Figure 6A-23.)

DISASSEMBLY

1. Remove the governor spring (21) from throttle control lever (6) and governor arm. Remove the choke linkage (9) from choke control lever (8) and choke lever on carburetor. Remove the kill switch lead from kill switch (2).
2. Remove the hex cap sems screw (22), hex cap screws (5, 18), plain washers (4, 19), and spacers (3, 20). Remove the control assembly from handle bracket and engine crankcase.
3. Remove the wing nut (10), plain washer (11), choke control lever (8), wave washer (12), spacer (13), locking tab (14), wave washer (15), and throttle control lever (6) from control bracket (1).
4. Remove high speed adjusting screw (16, 17), and bowden wire clamps (7) as necessary.

REASSEMBLY

1. Install high speed adjusting screw (16, 17), and bowden wire clamps (7) to control levers and bracket as necessary.
2. Install throttle control lever (6), wave washer (15), locking tab (14), spacer (13), wave washer (12), choke control lever (8), plain washer (11), and wing nut (10) to control bracket (1).
3. Install the control assembly to crankcase and handle bracket. Secure with the hex cap sems screw (22), spacers (3, 20), plain washers (4, 19), and hex cap screws (5, 18).
4. Install the choke linkage (9) to choke lever on carburetor and choke control lever (8). Install the governor spring (21) to governor arm and throttle control lever (6). Install the kill switch lead to kill switch (2).

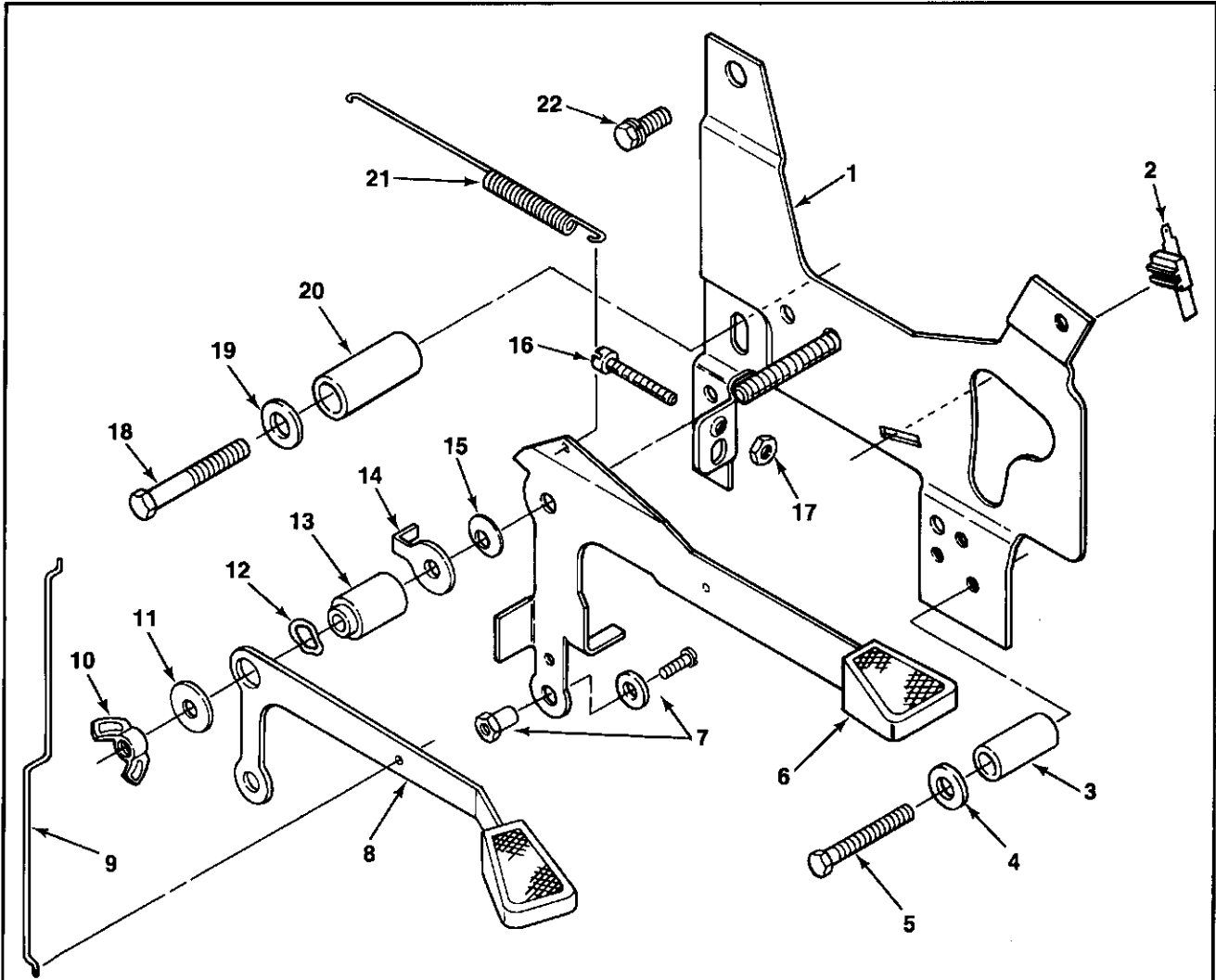

Index No.	Description
1	Control Bracket
2	Kill Switch
3	1" Spacer
4	#10 Plain Washer
5	#10-24x1-3/8" Hex Cap Screw
6	Throttle Control Lever
7	Bowden Wire Clamp
8	Choke Control Lever
9	Choke Linkage
10	Wing Nut
11	1/4" Plain Washer

Index No.	Description
12	Wave Washer
13	11/16" Spacer
14	Locking Tab
15	Wave Washer
16	#8-32x1" Fillister Head Screw (High Speed Adjusting Screw)
17	#8-32 Hex Nut (High Speed Adjusting Screw Lock Nut)
18	1/4-20x1-7/8" Hex Cap Screw
19	1/4" Plain Washer
20	1-7/32" Spacer
21	Governor Spring
22	1/4-20x1/2" Hex Cap Sems Screw

Figure 6A-23. Engine Mounted Throttle And Choke Controls - Model M8.

On Models M10, M12, M14, And M16 (Refer to Figure 6A-24.)

DISASSEMBLY

1. Remove the governor spring (1) from throttle control lever (5) and governor arm. Remove the choke linkage (47) from linkage retaining bushing (43, 44) in choke shaft (45).
2. Remove the wiring connector from keyswitch (22). Remove the kill switch lead from kill switch (19).
3. Remove the self-tapping screw securing stabilizer bracket (16) to blower housing/bearing plate. Remove the hex cap screw (27), split lock washer (26), and spacer (21). Remove the hex cap sems screws securing cam gear cover and control panel bracket (23) to crankcase.
4. Remove keyswitch (22, 24, 25) from control panel bracket (23).
5. Remove the choke knob (32), pan head screws (31), internal tooth lock washers (30), and panel with decal (28, 29).
6. Remove the hex cap sems screws (17), plain washers (18), and choke shaft bracket (36) from control panel bracket (23).
7. Remove the choke shaft (45) with e-ring (37). Remove hex cap sems screws (33), plain washers (34), and bowden wire bracket (49).
8. Remove the slotted hex cap screws (42), split lock washers (41), and bowden wire bracket (38).
9. Remove the bowden wire clamps (39, 48), choke shaft bushings (35), and linkage retaining bushings (43, 46) as necessary.
10. Remove the hex cap sems screw (14) and throttle control bracket assembly (15) from control panel bracket (23).
11. Remove the hex cap sems screw (10), plain washer (11), and stabilizer bracket (16) from throttle control bracket (15).
12. Remove the hex lock nut (2), locking tab (3), plain washer (4), throttle control lever (5), and wave washer (9) from throttle control bracket (15).
13. Remove bowden wire clamp (13), linkage retaining bushing (6), high speed adjusting screw (8), and nut (7) as necessary.

REASSEMBLY

1. Install the bowden wire clamp (13) to throttle control bracket (15).
 2. Install the linkage retaining bushing (6), high speed adjusting screw (8), and nut (7) to throttle control lever (5).
 3. Install the wave washer (9), throttle control lever (5), plain washer (4), locking tab (3), and hex lock nut (2) to throttle control bracket (15). Make sure the locking tab goes into the hole in throttle control bracket.

Torque hex lock nut to **15/25 in. lb.**
 4. Install the stabilizer bracket (16), plain washer (11), and hex cap sems screw (10) to throttle control bracket (15).
 5. Install the throttle control bracket assembly (15) and hex cap sems screw (14) to control panel bracket (23).
 6. Install the linkage retaining bushings (43, 46) to choke shaft (45).
 7. Install the choke shaft bushings (35) to choke shaft bracket (36).
 8. Install the bowden wire bracket (38), split lock washers (41), and slotted hex cap screws (42) to choke shaft bracket (36).
 9. Install the bowden wire bracket (49), plain washers (34), and hex cap sems screws (33) to choke shaft bracket (36).
 10. Install choke shaft (45) with e-ring (37) into bushings (35). Install the choke shaft bracket assembly (35), plain washers (18), and hex cap sems screws (17) to control panel bracket (23).
 11. Install the panel with decal (28, 29), internal tooth lock washers (30), and pan head screws (31). Install choke knob (32) to choke shaft (45).
 12. Install keyswitch (22, 24, 25) to control panel bracket (23).
 13. Secure the control panel bracket (23) and cam gear cover to crankcase using new gaskets and the hex cap sems screws removed previously. Install the spacer (21), split lock washer (26), and hex cap screw (27). Secure the stabilizer bracket (16) to blower housing/bearing plate with the self-tapping screw removed previously.
 14. Install the wiring connector to keyswitch (22). Install the kill switch lead to kill switch (19).
 15. Install the choke linkage (47) to linkage retaining bushing (43, 44) in choke shaft (45). Install the governor spring (1) to throttle control lever (5) and governor arm.
-

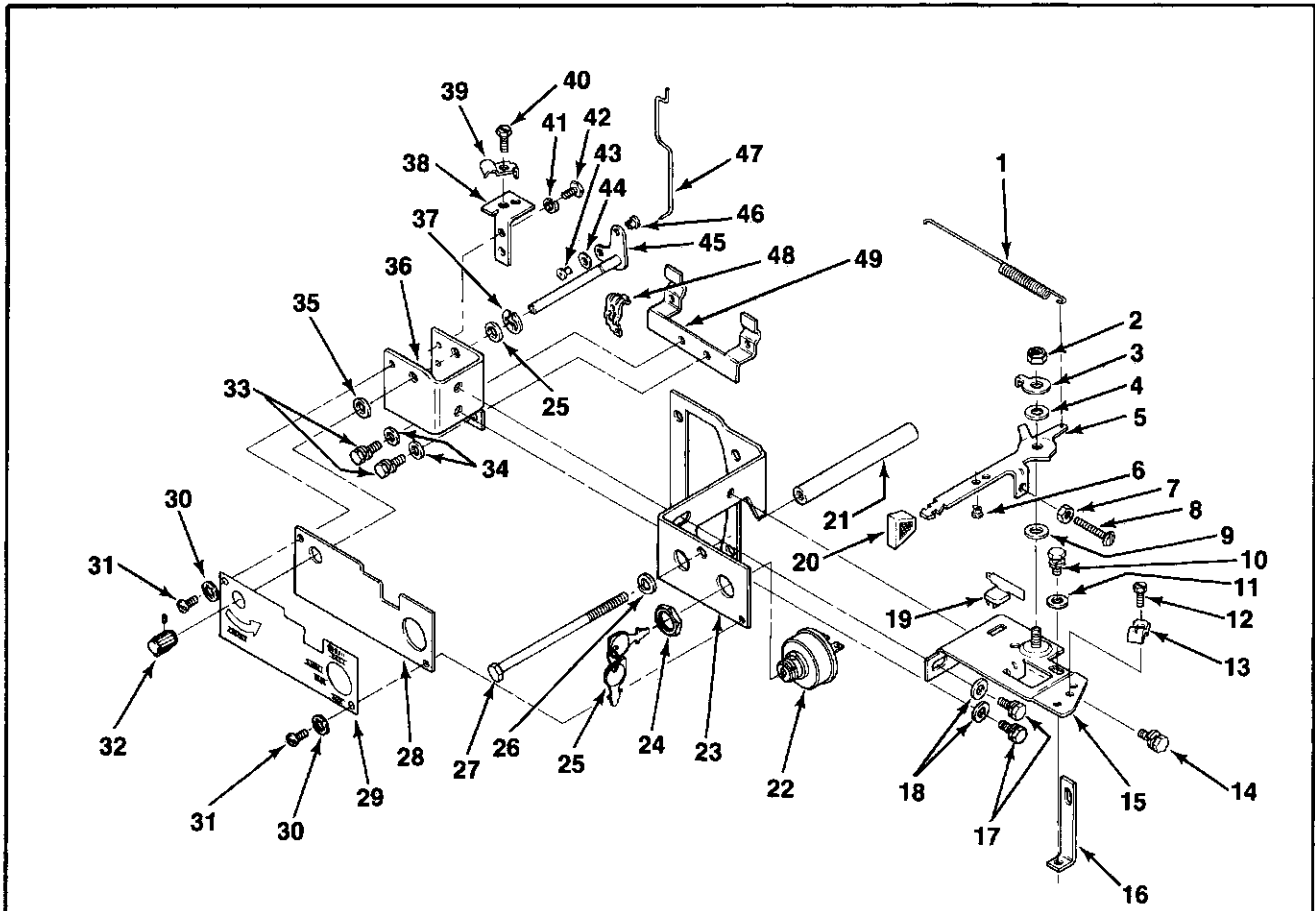

Index No.	Description
1	Governor Spring
2	1/4-20 Hex Lock Nut
3	Locking Tab
4	1/4" Plain Washer
5	Throttle Control Lever
6	Linkage Retaining Bushing (Black Plastic)
7	#10-24 Hex Nut (High Speed Adjusting Screw Lock Nut)
8	#10-24x3/8" Fillister Head Screw (High Speed Adjusting Screw)
9	1/4" Wave Washer
10	1/4-20x3/8" Hex Cap Sems Screw
11	1/4" Plain Washer
12	#10-24x3/8" Slt'd. Hex Head Screw
13	Bowden Wire Clamp
14	1/4-20x3/8" Hex Cap Sems Screw
15	Throttle Control Bracket
16	Stabilizer Bracket
17	1/4-20x5/8" Hex Cap Sems Screw (2)
18	1/4" Plain Washer (2)
19	Kill Switch
20	Knob
21	4-1/2" Spacer
22	Keyswitch
23	Control Panel Bracket
24	Hex Nut
25	Keys

Index No.	Description
26	1/4" Split Lock Washer
27	1/4-20x5-1/16" Hex Cap Screw
28	Panel
29	Decal
30	#10 Internal Tooth Lock Washer (2)
31	#10-24x3/8" Pan Head Screw (2)
32	Choke Knob
33	#10-24x1/2" Hex Cap Sems Screw (2)
34	1/4" Plain Washer (2)
35	Choke Shaft Bushing (2)
36	Choke Shaft Bracket
37	E-Ring
38	Bowden Wire Bracket
39	Bowden Wire Clamp
40	#10-24x3/8" Slt'd. Hex Head Screw
41	#10 Split Lock Washer (2)
42	#10-24x3/8" Slt'd. Hex Head Screw (2)
43	Linkage Retaining Bushing (White Plastic)
44	3/16" Plain Washer
45	Choke Shaft
46	Linkage Retaining Bushing (Black Plastic)
47	Choke Linkage
48	Bowden Wire Clamp (2)
49	Bowden Wire Bracket

Figure 6A-24. Engine Mounted Throttle And Choke Controls - Models M10, M12, M14, And M16.

MAGNUM

Single Cylinder Engine
Service Manual
Models M8, M10, M12
M14, M16
TP-2203-A 3/86

KOHLER
engines

RETRACTABLE STARTERS

WARNING: Spring Under Tension!



Retractable starters contain a powerful, flat wire recoil spring that is under tension. Do not remove the center screw from starter until the spring tension is released. Removing the center screw before releasing spring tension, or improper starter disassembly, can cause the sudden and potentially dangerous release of the spring.

Always wear safety goggles when servicing retractable starters—full face protection is recommended.

To ensure personal safety and proper starter disassembly, the following procedures must be followed carefully.

TO REMOVE STARTER

1. Remove the five screws securing the starter assembly to blower housing.

TO INSTALL STARTER

1. Install starter to blower housing using the five mounting screws. Leave screws slightly loose.
2. Pull the handle out approx. 8 to 10" until the pawls engage in the drive cup. Hold the handle in this position and tighten the screws securely. Refer to Figure 7-1.

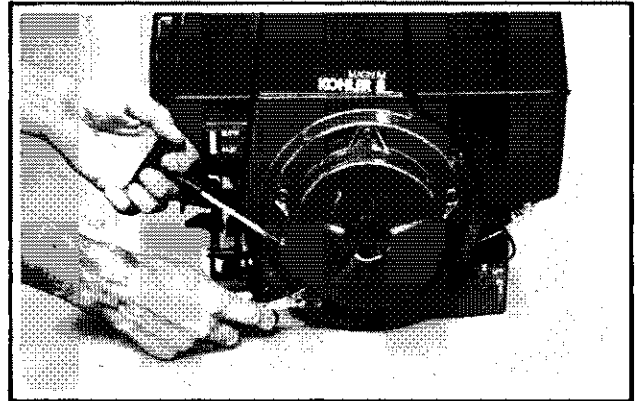

Figure 7-1. Installing Retractable Starter.

RETRACTABLE STARTER ON MODEL M8

To Replace Starter Pawls (Dogs)

Use pawl repair kit no. 41 757 02. This kit includes two starter pawls, two pawl springs, two retaining rings, and installation instructions.

1. Remove the starter from engine.

WARNING: Spring Under Tension!



Do not remove the center screw of the starter when replacing pawls. Removal of the center screw can cause the sudden and potentially dangerous release of the recoil spring. It is not necessary to remove the center screw when making this repair.

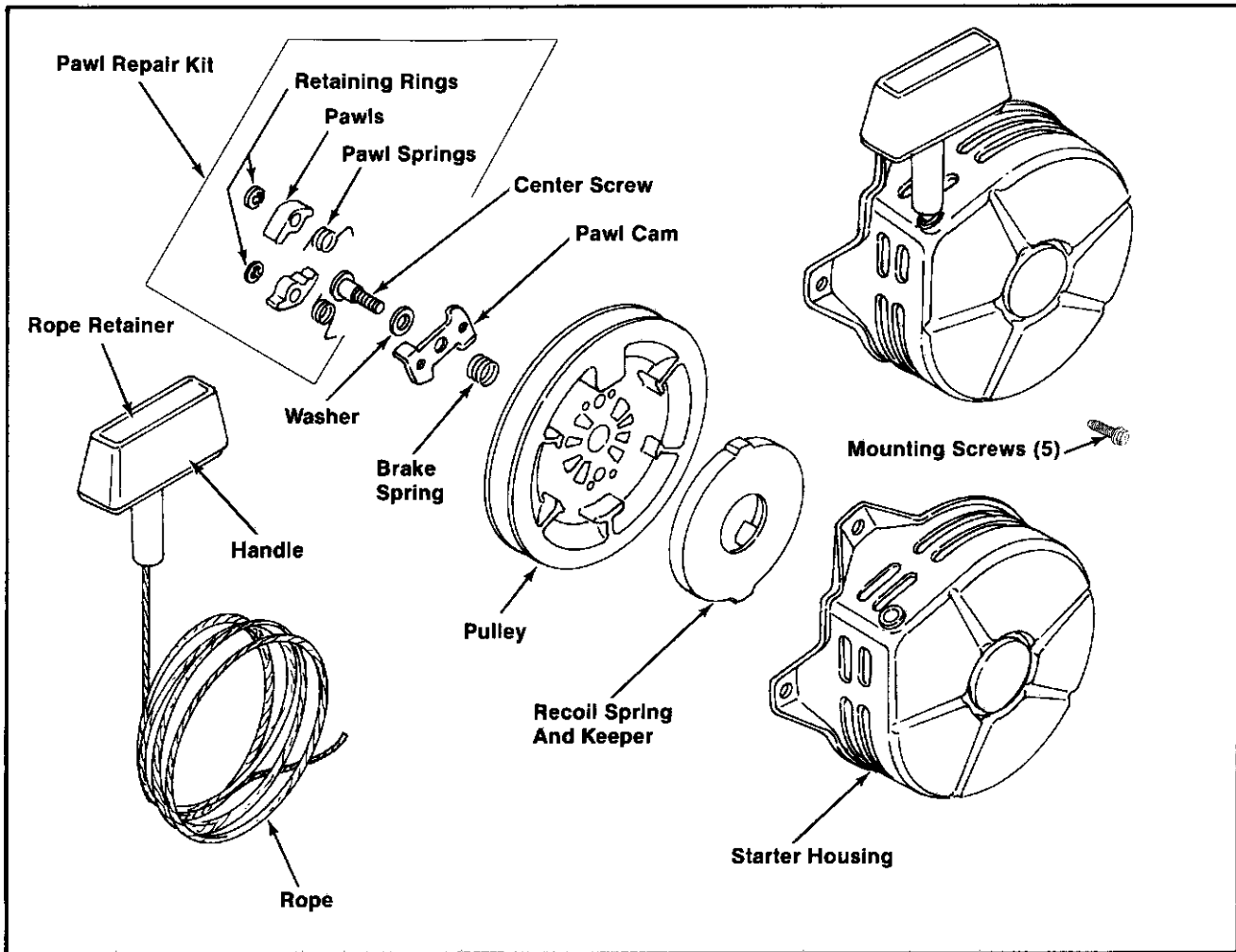

Figure 7-2. Exploded View—Retractable Starter for Model M8

2. Carefully note the position of the pawls, pawl springs, and retaining rings before disassembly. (Components must be assembled correctly for proper operation.) Refer to Figure 7-3.

3. Remove the retaining rings, pawls, and pawl springs from pins on pulley.

4. Clean pins and lubricate them with any commercially available bearing grease.

5. Install new pawl springs, pawls, and retaining rings. When properly installed, the pawl springs will hold the pawls against the pawl cam.

CAUTION: Make sure the retaining rings are securely seated in grooves of pins. Failure to seat the retaining rings can cause pawls to dislodge during operation.

6. Pull rope to make sure pawls operate properly.

7. Install starter to engine as instructed under "To Install Starter".

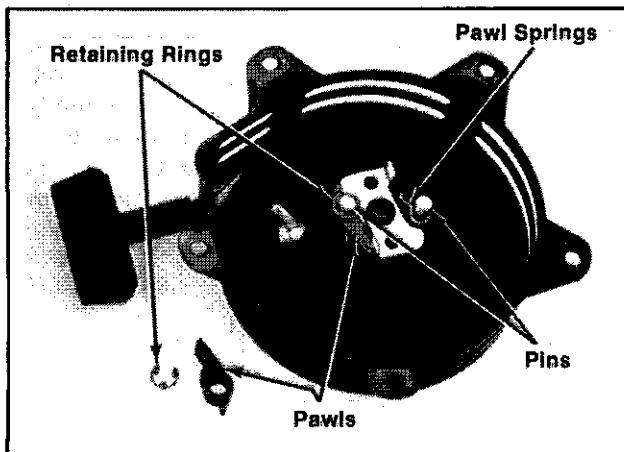

Figure 7-3. Starter Pawls.

To Replace Rope

The rope can be replaced without complete starter disassembly.

1. Remove the starter from engine.
2. Pull the rope out approx. 12" and tie a temporary (slip) knot in it to keep it from retracting into starter. Refer to Figure 7-4.

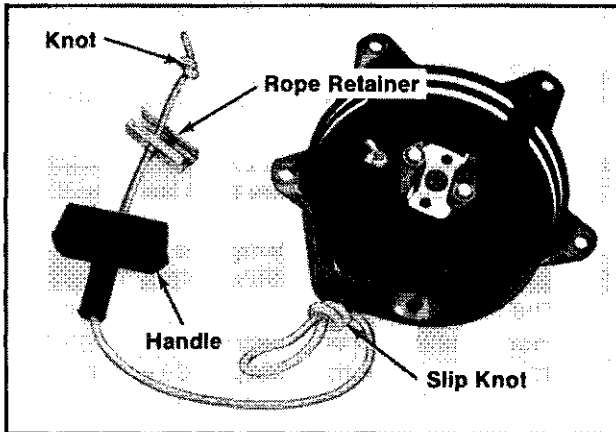

Figure 7-4. Removing Handle.

3. Remove the rope retainer from inside handle. Untie the knot and remove the retainer and handle.
4. Hold the pulley firmly with thumb and untie the slip knot. Allow the pulley to rotate **slowly** as the spring tension is released. Refer to Figure 7-5.

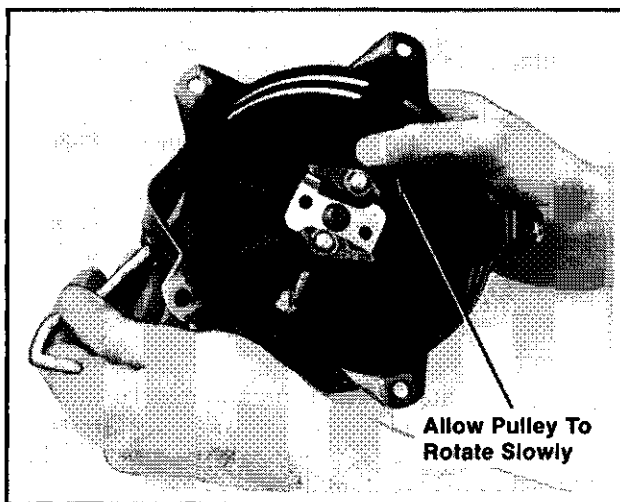

Figure 7-5. Releasing Spring Tension.

5. When all spring tension on the starter pulley is released, remove old rope from pulley.
6. Tie a single knot in one end of new rope.
7. Rotate the pulley counterclockwise (when viewed from pawl side of pulley) until the spring is tight. (Approx. 6 full turns of pulley).
8. Rotate the pulley clockwise until the rope pocket is aligned with the rope guide bushing of housing.

NOTE: Do not allow pulley/spring to unwind. Enlist the aid of a helper if necessary, or use a c-clamp to hold pulley in position.

9. Insert the new rope into the rope pocket of pulley and through rope guide bushing in housing. Refer to Figure 7-6.

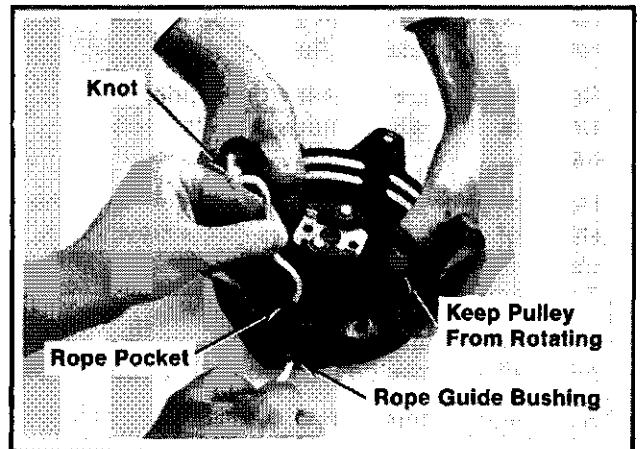

Figure 7-6. Installing Rope.

10. Tie a slip knot approx. 12" from the free end of rope. Hold pulley firmly with thumb and allow pulley to rotate **slowly** until the temporary knot reaches the rope guide bushing in housing.
11. Slip the handle and rope retainer onto rope. Tie a single knot at the end of rope and install rope retainer into handle. Refer to Figure 7-4.
12. Untie the slip knot in rope and pull the handle out until the rope is fully extended. Slowly retract the rope into the starter. If the spring has been properly tensioned, the rope will fully retract until the handle hits the housing.

Disassembly

1. Remove the starter from engine.

WARNING: Spring Under Tension!



Do not remove the center screw from starter until the spring tension is released. Removing the center screw before releasing spring tension, or improper starter disassembly, can cause the sudden and potentially dangerous release of the spring. Follow these instructions carefully to ensure personal safety and proper starter disassembly. Make sure adequate face protection is worn by all persons in the area.

2. Pull the rope out approx. 12" and tie a temporary (slip) knot in it to keep it from retracting into starter. Refer to Figure 7-4.
3. Remove the rope retainer from inside handle. Untie the knot and remove the retainer and handle.
4. Hold the pulley firmly with thumb and untie the slip knot. Allow the pulley to rotate **slowly** as the spring tension is released. Refer to Figure 7-5.
5. When all spring tension on the pulley has been released, remove the rope from the pulley.
6. Remove the center screw, washer, pawl cam, and brake spring.
7. Rotate the pulley clockwise 2 full turns. This will ensure the pulley is disengaged from the spring.
8. Hold pulley into starter housing and invert starter so the pulley is away from your face, and away from others in the area.
9. Rotate the pulley slightly from side to side and **carefully** separate the pulley from the starter housing. Refer to Figure 7-7.

If the pulley and housing do not separate easily, the spring could be engaged with the pulley, or there is still tension on the spring. Return the pulley to the housing and repeat step 7 before separating the pulley and housing.

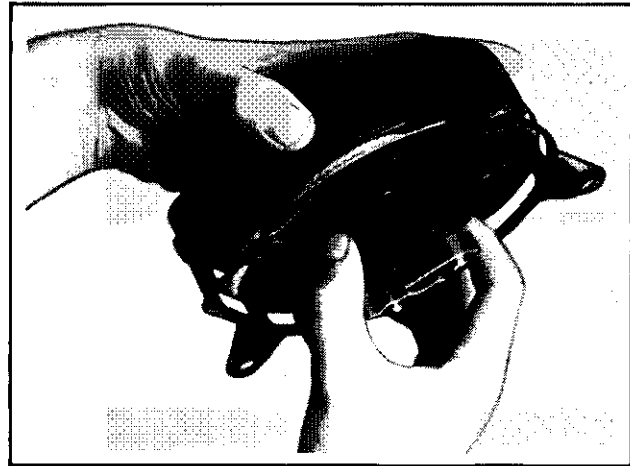

Figure 7-7. Removing Pulley From Housing.

10. Note the position of the spring and keeper assembly on the pulley. Also refer to Figure 7-8. (The spring and keeper assembly must be correctly positioned on pulley for proper operation.) Remove the spring and keeper assembly from the pulley **as a package**.

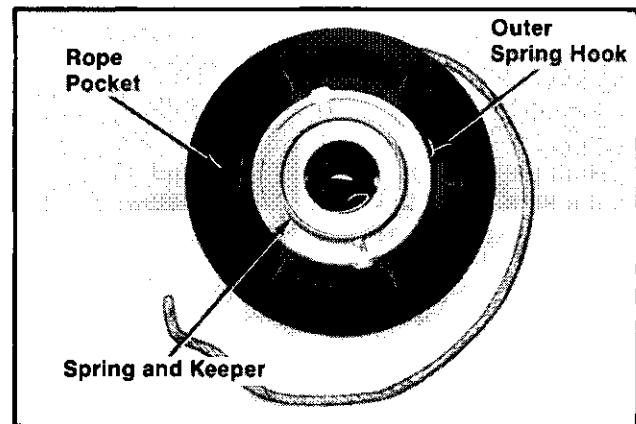

Figure 7-8. Position Of Spring And Keeper On Pulley.

WARNING: Spring Under Tension!



Do not remove the spring from the keeper. Severe personal injury could result from the sudden uncoiling of the spring.

11. Remove the rope from pulley. If necessary, remove the starter pawl components from pulley as instructed under "To Replace Starter Pawls".

Inspection And Service

1. Carefully inspect rope, starter pawls, housing, center screw, and other components for wear or damage.
2. Replace all worn or damaged components. Use only genuine Kohler replacement parts specified in the Parts Manual. All components shown in Figure 7-2 are available as service parts. Do not use nonstandard parts.
3. Do not attempt to rewind a spring that has come out of the keeper. Order and install a new spring and keeper assembly.
4. Clean all old grease and dirt from starter components. Generously lubricate the spring, and the center shaft of starter housing with any commercially available bearing grease.

Reassembly

1. Make sure spring is well lubricated with grease. Position the spring and keeper assembly to pulley (side opposite pawls). The outside spring tail must be positioned opposite the rope pocket. Refer to Figure 7-8.
2. Install the pulley with spring and keeper assembly into the starter housing. Refer to Figure 7-9.

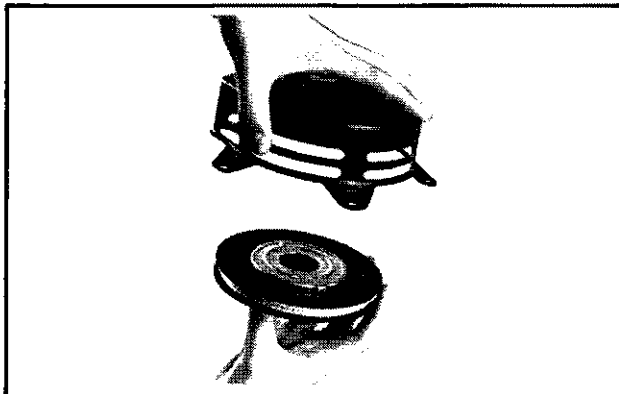

Figure 7-9. Installing Pulley And Spring Into Housing.

The pulley is in position when the center shaft is extending slightly above the face of the pulley. **Do not wind the pulley and recoil spring at this time.**

3. Lubricate the brake spring **sparingly** with grease. Install the brake spring into the recess in center shaft of starter housing. Refer to Figure 7-2. (Make sure the threads in center shaft remain clean, dry, and free of grease or oil.)
4. Apply a small amount of Loctite #271 to the threads of center screw. Install the center screw with washer and cam to the center shaft. Torque screw to **65/75 in. lb.**
5. If necessary, install the pawl springs, pawls, and retaining rings to pins on starter pulley. Refer to "To Replace Starter Pawls".
6. Tension the spring and install the rope and handle as instructed in steps 5 through 12 under "To Replace Rope".
7. Install the starter to engine.

RETRACTABLE STARTER ON MODELS M10, M12, M14, and M16

Disassembly

1. Remove the starter from engine.

WARNING: Spring Under Tension!



Do not remove the center screw from starter until the spring tension is released. Removing the center screw before releasing spring tension, or improper starter disassembly, can cause the sudden and potentially dangerous release of the spring. Follow these instructions carefully to ensure personal safety and proper disassembly. Make sure adequate face protection is worn by all persons in the area.

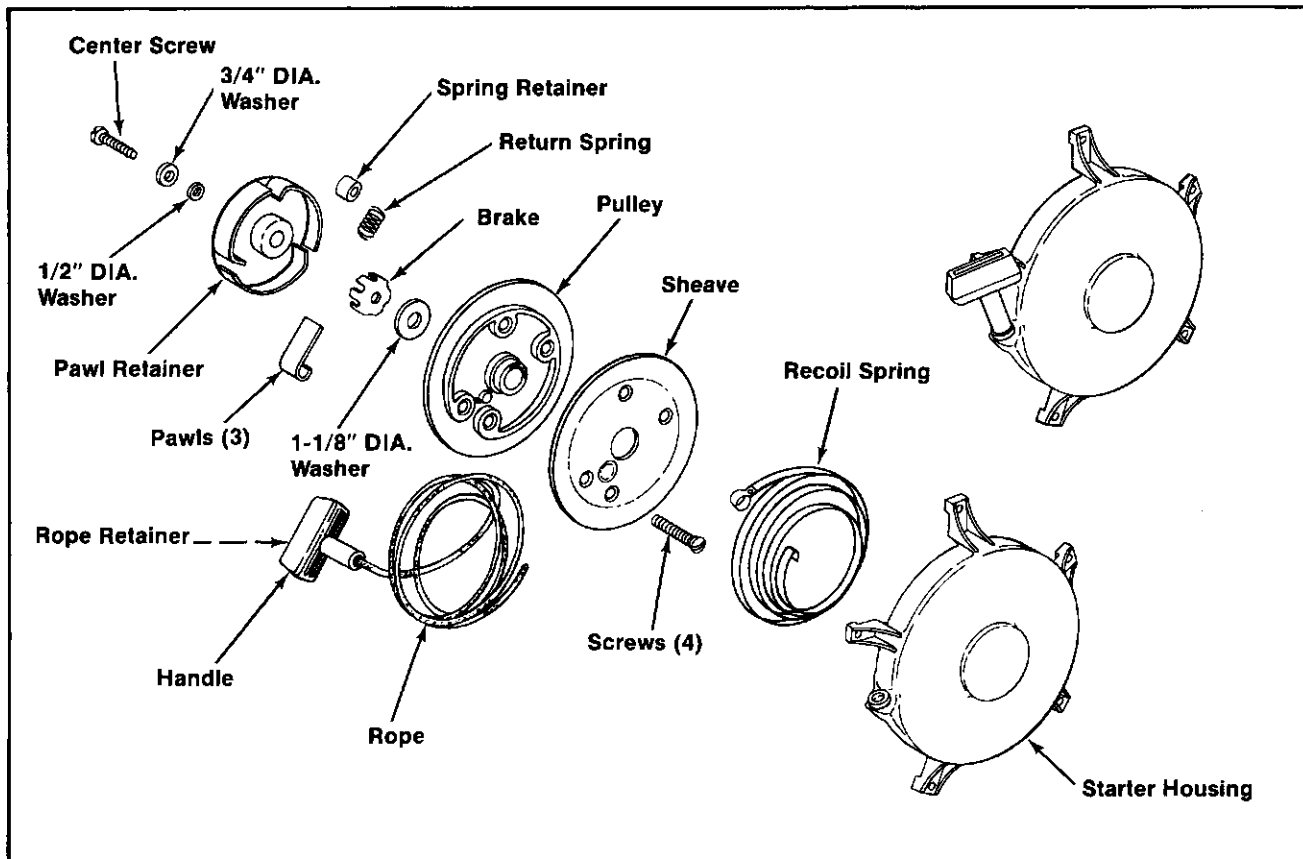

Figure 7-10. Exploded View—Retractable Starter For Models M10, M12, M14, and M16.

2. Pull the rope out approx. 12" and tie a temporary (slip) knot in it to keep it from retracting into starter. Refer to Figure 7-11.

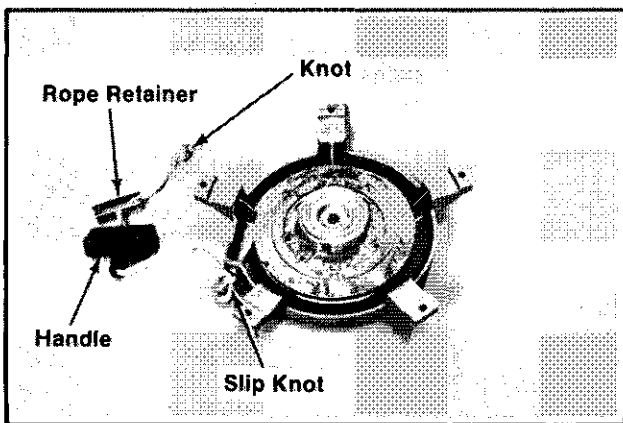

Figure 7-11. Removing Handle.

3. Remove the rope retainer from inside handle. Untie the knot and remove retainer and handle.
4. Rotate the pulley counterclockwise until the notch in pulley is next to the rope guide bushing.
5. Hold the pulley firmly to keep it from turning. Untie the slip knot and pull the rope through the bushing.
6. Place the rope into the notch in pulley. This will keep the rope from interfering with the starter housing leg reinforcements as the pulley is rotated (step 7).
7. Hold the housing and pulley with both hands. Release pressure on the pulley and allow it to rotate **slowly** as the spring tension is released. Be sure to keep the rope in the notch. Refer to Figure 7-12.

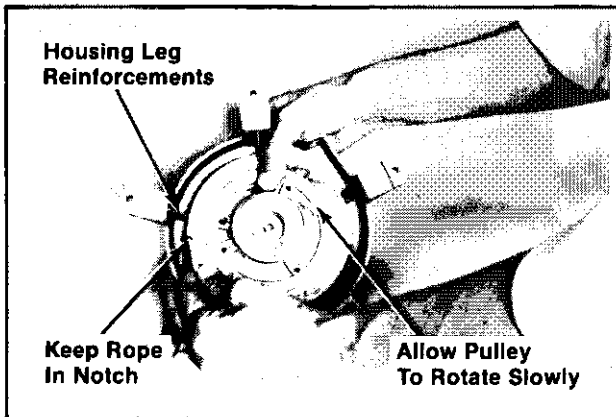

Figure 7-12. Releasing Spring Tension.

8. Make sure the spring tension is fully released. (The pulley should rotate easily in either direction.)
9. When **all** spring tension on the pulley is released, remove the center screw, 3/4" DIA. washer, and 1/2" DIA. washer.
10. **Carefully** lift the pawl retainer from pulley. Refer to Figure 7-13.

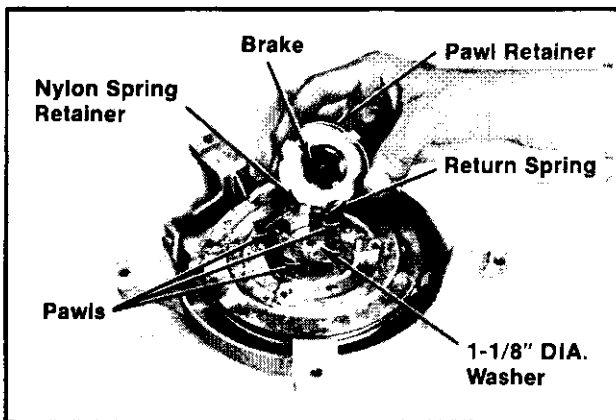

Figure 7-13. Removing Pawl Retainer, Pawls, And Related Components.

CAUTION: A small return spring and nylon spring retainer (spacer) are located under the pawl retainer. These parts are fragile and can be easily lost or damaged. If necessary, use a small screwdriver to loosen the spring retainer from the post on pulley. Replace the spring if it is broken, stretched, or shows other signs of damage.

11. Remove the 1-1/8" DIA. thrust washer, brake, return spring, nylon spring retainer, and pawls.

12. Rotate the pulley clockwise 2 full turns. There should be no resistance to this rotation. This will ensure the pulley is disengaged from the recoil spring.
13. Hold the pulley into the starter housing and invert starter so the pulley is away from your face and others in the area.
14. Rotate the pulley slightly from side to side and **carefully** separate the pulley from the starter housing. Refer to Figure 7-14.

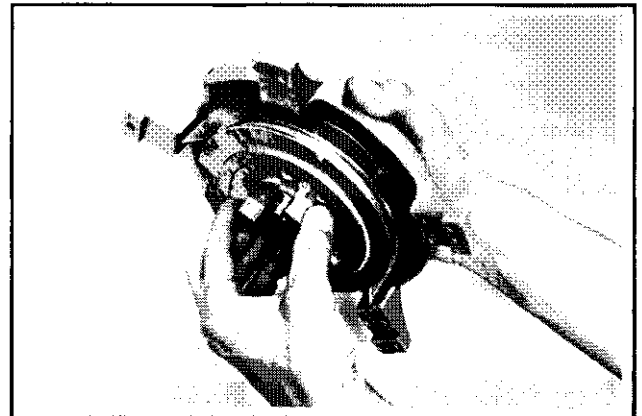

Figure 7-14. Removing Pulley From Housing.

If the pulley and housing do not separate easily, the spring could be engaged with the pulley, or there is still tension on the spring. Return the pulley to the housing and repeat step 12 before separating the pulley and the housing.

15. Only if it is necessary for the repair of starter, remove the spring from the starter housing as instructed under "To Replace Recoil Spring." **Do not remove the spring unless it is absolutely necessary.**

Inspection And Service

1. Carefully inspect the rope, starter pawls, housing, center screw, center shaft, spring, and other components for wear or damage.
2. Replace all worn or damaged components. Use only the genuine Kohler replacement parts specified in the appropriate Parts Manuals. All components shown in Figure 7-10 are available as service parts. Do not use nonstandard parts.
3. Carefully clean all old grease and dirt from starter components. Lubricate the spring, center shaft, and certain other components as specified in these instructions with any commercially available bearing grease.

To Replace Rope

The starter must be completely disassembled to replace the rope.

1. Remove the starter from engine.
2. Disassemble starter as instructed in steps 2 through 14 under "Disassembly."
3. Remove the 4 Phillips head screws securing the pulley and sheave. Separate the pulley and sheave and remove the old rope. Refer to Figure 7-15.
4. Position the new rope in the notch in the pulley and around the rope lock post.

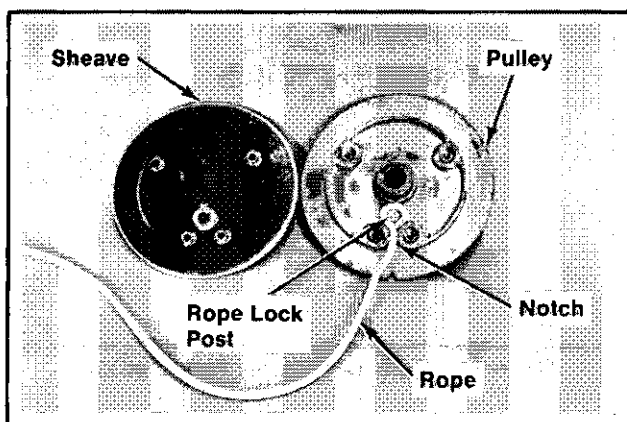

Figure 7-15. Replacing Rope.

CAUTION: Use only a genuine Kohler replacement rope which is designed for this starter. Using rope of the incorrect diameter and/or type will not lock properly in the pulley.

5. Install the sheave to the pulley and install the 4 Phillips head screws. Use care not to strip or cross-thread the threads in pulley.
6. Inspect the pulley to make sure the sheave is securely joined to the pulley. Pull firmly on the rope to make sure it is securely retained in the pulley.

To Replace Recoil Spring

WARNING: Spring Under Tension!



Do not attempt to pull or pry the recoil spring from the housing. Doing so can cause the sudden and potentially dangerous release of the spring from the housing. Follow these instructions carefully to ensure personal safety and proper spring replacement. Make sure adequate face protection is worn throughout the following procedure.

1. Carefully note the position of the spring in the housing. Also refer to Figure 7-16. The new spring must be installed in the proper position—it is possible to install it backwards in the housing.

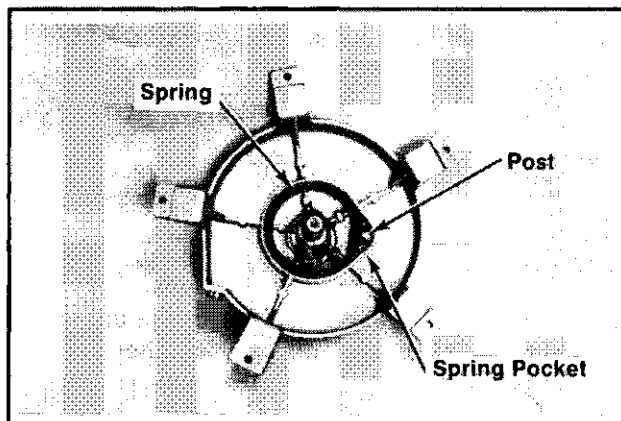

Figure 7-16. Position Of Spring In Housing.

2. Place the housing on a flat wooden surface with the recoil spring and center shaft down and away from you.
3. Grasp the housing by the top so that your fingers are protected. Do not wrap your fingers around the edge of the housing.
4. Lift the housing and rap it firmly against the wooden surface. Repeat this procedure until the spring is released from the spring pocket in housing. Refer to Figure 7-17.

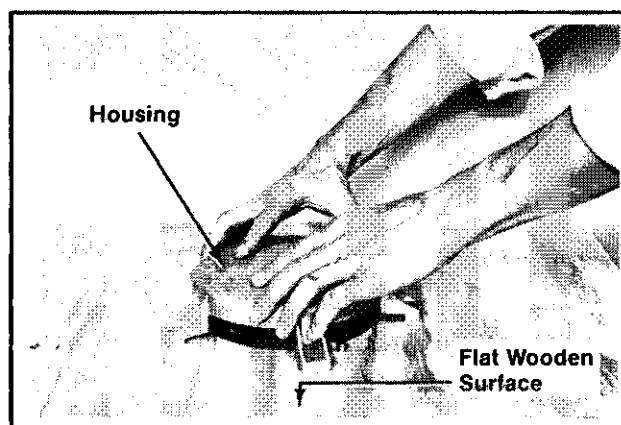

Figure 7-17. Removing Spring From Housing.

5. Discard the old spring.

WARNING: Old Spring Cannot Be Reinstalled!



Do not attempt to rewind or reinstall a spring once it has been removed from the starter housing. Severe personal injury could result from the sudden uncoiling of the spring. Always order and install a new spring which is held in a specially designed "c-ring" spring retainer.

6. Thoroughly clean the starter housing removing all old grease and dirt.
7. **Carefully** remove the masking tape surrounding the new spring/c-ring.
8. Position the spring/c-ring to the housing so the spring hook is over the post in the housing. Make sure the spring is coiled in the correct direction. Refer to Figures 7-16 and 7-18.

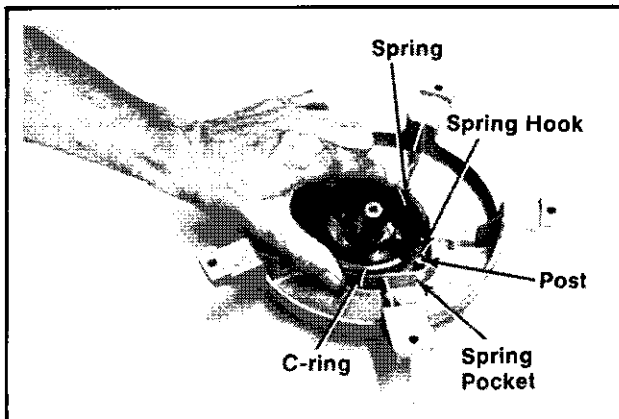

Figure 7-18. Positioning New Spring/C-ring.

9. Obtain Seal Installer #11791 and Handle #11795. (Refer to the "Special Tools" Section.)
Hook the spring hook over the post in housing. Make sure the spring/c-ring is centered over the spring pocket in housing. Drive the spring out of the c-ring and into the spring pocket using the seal installer and handle. Refer to Figure 7-19.
10. Make sure all of the spring coils are bottomed against ribs in spring pocket. Use the seal installer and handle to bottom the coils, as necessary.
11. Lubricate the spring moderately with wheel bearing grease before reassembling the starter.

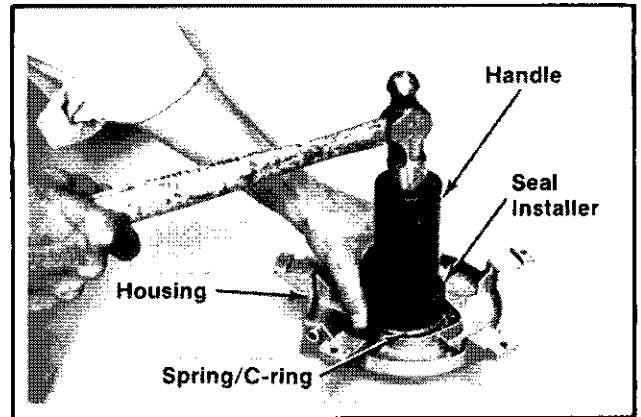

Figure 7-19. Installing Spring Using Seal Installer And Handle.

Reassembly

1. Install the recoil spring into the starter housing as instructed under "To Replace Recoil Spring."
2. Springly lubricate the center shaft of starter with wheel bearing grease.
3. Make sure the rope is in good condition. If necessary, replace the rope as instructed under "To Replace Rope."

Ready the pulley and rope for assembly by unwinding all of the rope from pulley. Place the rope into the notch in pulley. This will keep the rope from interfering with the starter housing leg reinforcements as the pulley is rotated later during reassembly.

4. Install the pulley onto the center shaft.

If the pulley does not seat fully, it is resting on the inner spring coil. Rotate the pulley slightly from side to side while exerting slight downward pressure. This should move the inner spring coil out of the way and allow the pulley to drop into position.

The pulley is in position when the center shaft is flush with the face of the pulley. **Do not wind the pulley and recoil spring at this time.**

5. Install the starter pawls into the appropriate pockets in the pulley. Refer to Figure 7-20.

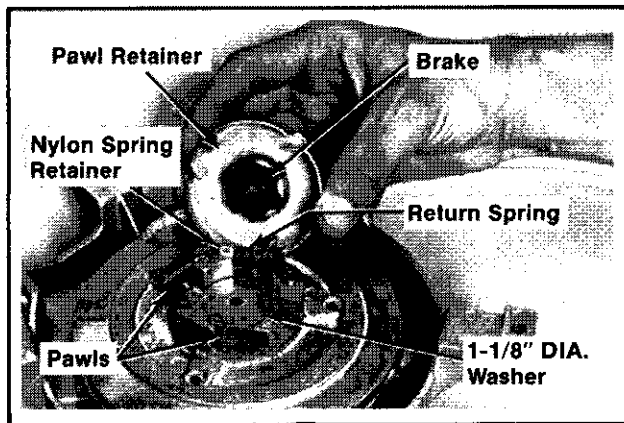

Figure 7-20. Installing Pawls, Pawl Retainer, And Related Components.

6. **Sparingly** lubricate the underside of the 1-1/8" DIA. washer with grease and install it over the center shaft. Make sure the threads in center shaft remain clean, dry, and free of grease or oil.
7. **Sparingly** lubricate the insides of the "legs" of the brake spider with grease. Install the brake to the retainer.
8. Install the small return ring to the pawl retainer. Make sure it is positioned properly.
9. Position the pawl retainer and return spring next to the small post on pulley. Install the free loop of the return spring over the post. Install the nylon spring retainer over the post.
10. Invert the pawl retainer over the pawls and center hub of pulley. Take great care not to damage or unhook the return spring. Make sure the pawls are positioned in the slots of pawl retainer.
11. As a test, rotate the pawl retainer slightly clockwise. Pressure from the return spring should be felt. In addition, the pawl retainer should return to its original position when released.

If no spring pressure is felt or the retainer does not return, the spring is damaged, unhooked, or improperly assembled. Repeat steps 8, 9, and 10 to correct the problem.

12. **Sparingly** lubricate the 1/2" DIA. washer and 3/4" DIA. washer with grease. Install the 1/2" DIA. washer then the 3/4" DIA. washer in the center of pawl retainer. Make sure the threads in center shaft remain clean, dry, and free of grease or oil.

13. Apply a small amount of Loctite #271 to the threads of center screw. Install the center screw to center shaft. Torque screw to **55/70 in. lb.**
14. Rotate the pulley counterclockwise (when viewed from the pawl side of pulley) until the spring is tight. (Approx. 4 full turns of pulley.) Make sure the fully extended rope is held in the notch in pulley to prevent interference with the housing leg reinforcements. Refer to Figure 7-21.

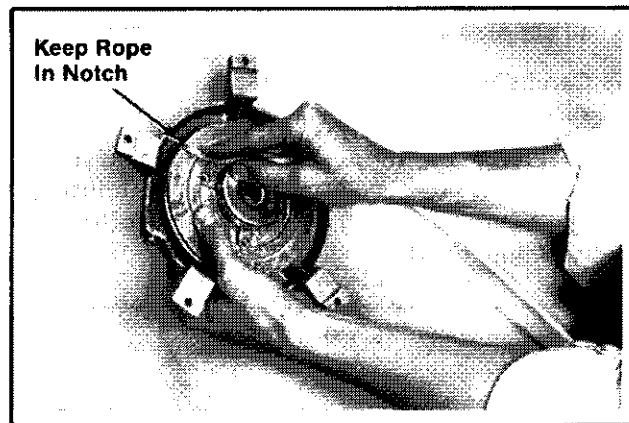

Figure 7-21. Tensioning Spring.

15. Rotate the pulley clockwise until the notch is aligned with the rope guide bushing of housing.
- NOTE:** Do not allow the pulley/spring to unwind. Enlist the aid of a helper, or use a c-clamp to hold pulley in position.
16. Insert the free end of rope through rope guide bushing. Tie a temporary (slip) knot approx. 12" from the free end of rope.
 17. Hold the pulley firmly with thumbs and allow the pulley to rotate **slowly** until the slip knot reaches the rope guide bushing of housing. Refer to Figure 7-22.

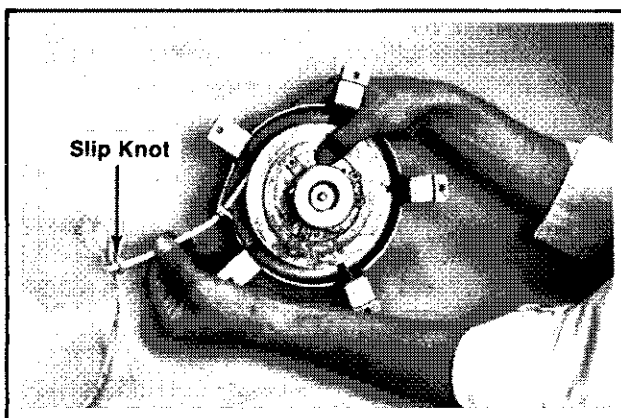

Figure 7-22. Winding Rope Onto Pulley.

18. Slip the handle and rope retainer onto rope.
Tie a single knot at the end of rope and install rope retainer into handle. Refer to Figure 7-11.
19. Untie the slip knot and pull the handle out until the rope is fully extended. Slowly retract the rope into the starter. If the spring has been properly tensioned, the rope will fully retract until the handle hits the housing.

MAGNUM

Single Cylinder Engine
Service Manual
Models M8, M10, M12
M14, M16
TP-2203-A 3/86

KOHLER
engines

ELECTRICAL SYSTEMS AND COMPONENTS

MAGNUM ELECTRONIC MAGNETO IGNITION SYSTEM

This engine is equipped with a state-of-the-art electronic magneto ignition system. The system consists of the following components (refer to Figure 8-1):

- A magnet assembly, which is PERMANENTLY affixed to the flywheel.
- An electronic magneto ignition module, which is mounted to the engine bearing plate.
- A kill switch or keyswitch which stops the engine by grounding the ignition module.

Operation

As the flywheel rotates and the magnet assembly moves past the ignition module, a low voltage is induced in the primary windings of the module. When the primary voltage is precisely at its peak,

the module induces a high voltage in its secondary windings. This high voltage creates a spark at the tip of the spark plug, igniting the fuel-air mixture in the combustion chamber. The timing of the spark is automatically controlled by the module. Therefore, no ignition timing adjustments are necessary or possible with this system.

CAUTION: Do not connect 12 volts to the ignition system or to any wire connected to the ignition module.

The ignition system operates independently of the battery, starting, charging, and other auxiliary electrical systems. Connecting 12 volts to the ignition module can cause the module to burn out. This type of damage is not covered by the engine warranty.

A break-before-make type keyswitch is required to prevent damage to the ignition module.

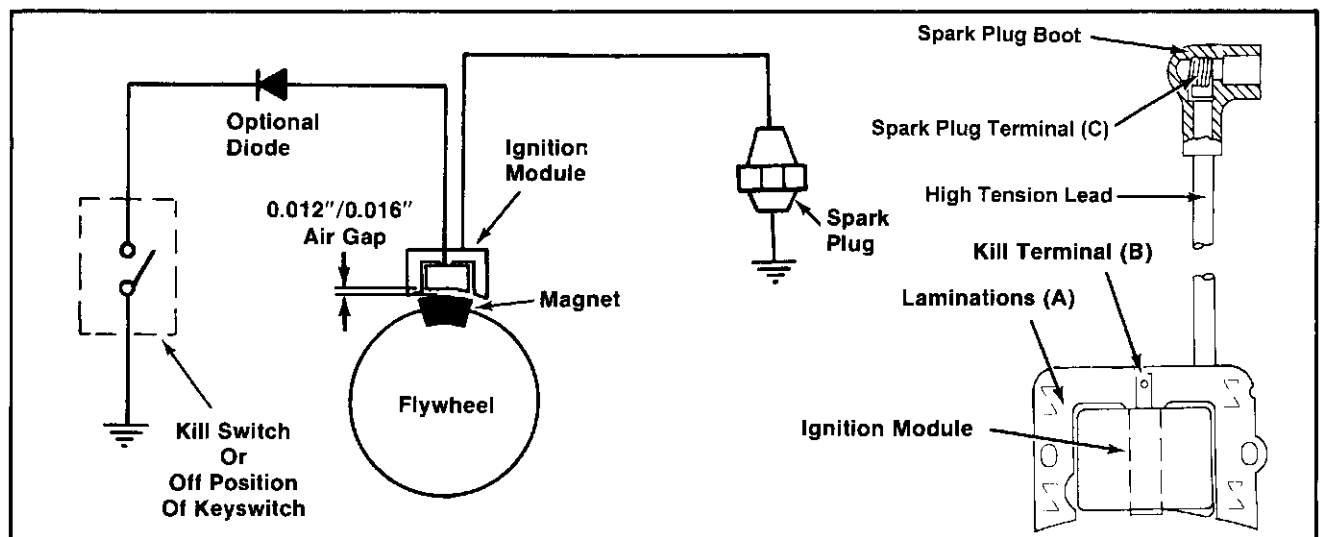

Figure 8-1. Magnum Electronic Magneto Ignition System.

Ignition System Troubleshooting Guide

The following guide will help locate and correct ignition system problems.

Problem	Test	Conclusion
ENGINE WILL NOT START	1. Make sure the spark plug lead is connected to the spark plug.	
	2. Check the condition of spark plug. Make sure gap is set to 0.025".	2. If plug is in good condition, check/adjust gap and reinstall.
	3a. Test for spark with Kohler ignition tester, Part No. 25 455 01. Disconnect spark plug lead and connect it to the post terminal of the tester. (See Figure 8-2.) Connect the clip to a good ground, not to the spark plug. NOTE: To maintain engine speeds normally obtained during cranking, do not remove the engine spark plug. b. Make sure the engine ignition switch, kill switch, or key switch is in the "run" position. c. Crank the engine and observe the test plug. Visible and audible sparks should be produced.	3. If visible and audible sparks are produced, the ignition module is OK. If visible and audible sparks are not produced: a. Make sure the engine ignition switch, kill switch, or key switch is in the "run" position. b. Check wires and terminals of ignition module and other components for accidental grounding and damaged insulation. c. If wires and terminals are OK, the ignition module is probably faulty and should be replaced. Test module further using an ohmmeter (Test 4).
	4. Measure the resistance of module secondary using an ohmmeter (see Figures 8-1 and 8-3): Zero ohmmeter before testing. Connect one ohmmeter lead to laminations (A). Connect the other lead to the spark plug terminal (C) of high-tension lead. With the ohmmeter leads connected in this manner, the resistance of secondary should be 7,900 to 20,000 ohms . NOTE: This test cannot be performed unless module has been fired at least once.	4. If the resistance is low or 0 ohms , the module secondary is shorted. Replace the module. If the resistance is high or infinity ohms , the module secondary is open. Replace the module. If the resistance is within the specified range, the module secondary is OK.

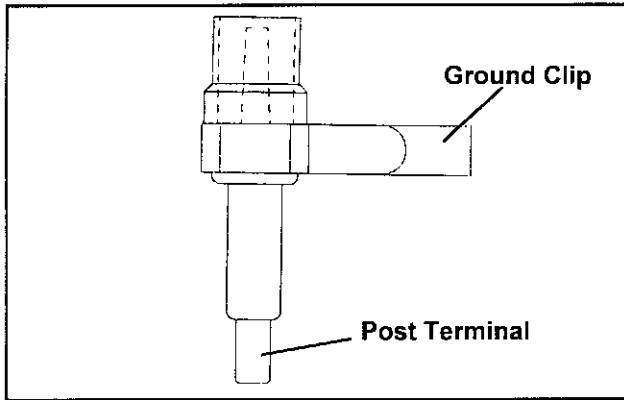

Figure 8-2. Ignition Tester 25 455 01.

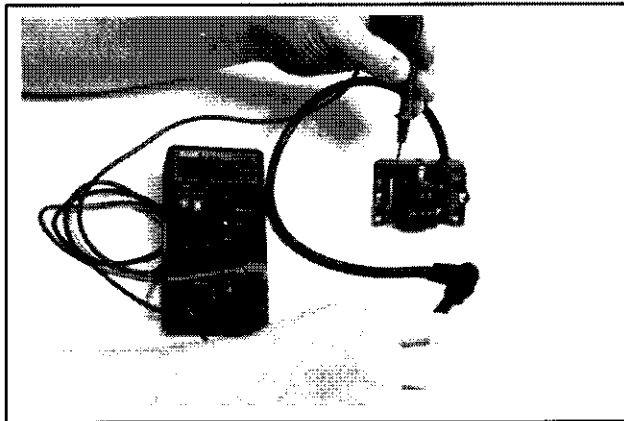

Figure 8-3. Testing Module Secondary.

Ignition Module

REMOVAL

1. Remove the high-tension lead and kill lead from slots in air baffle. Remove the kill lead from kill terminal of module. Refer to Figure 8-4.

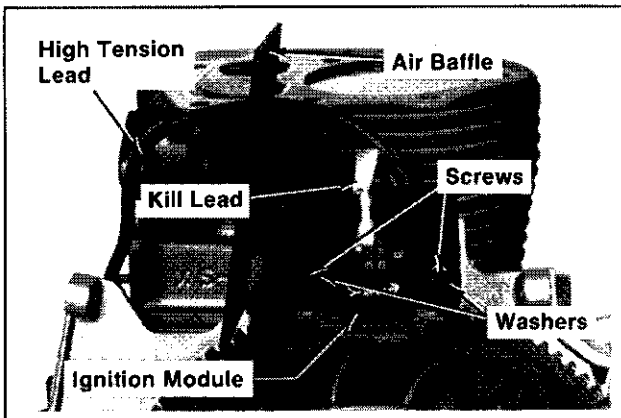

Figure 8-4. Removing Ignition Module.

2. Remove the hex. cap sems screws, plain washers, module, and air baffle.
3. Separate the module and air baffle.

INSTALLATION

1. Install the module, plain washers, and hex. cap sems screws. Move the module as far from flywheel/magnet as possible – tighten the screws slightly.
2. Insert a 0.018" flat feeler gauge (or shim stock) between the magnet and module. Refer to Figure 8-5.

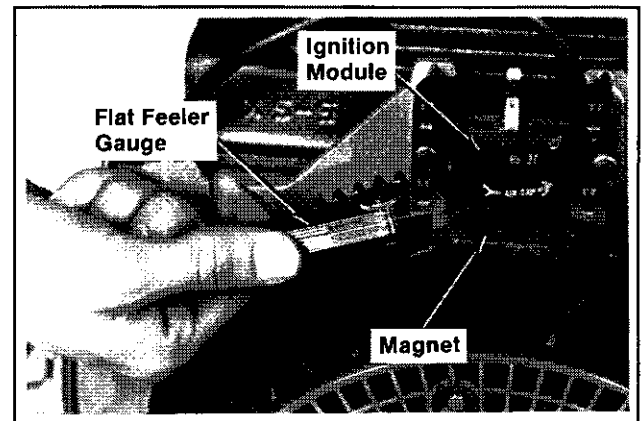

Figure 8-5. Setting Magnet-To-Module Air Gap.

3. Loosen the hex. cap sems screws so the magnet pulls module down. Tighten the screws to 32 in. lb.
4. Remove the feeler gauge or shim stock. Due to the pull of the magnet, the bearing plate will flex slightly. The magnet-to-module air gap should be within the range of 0.012"/0.016".

5. Rotate the flywheel back and forth; check to make sure the magnet does not strike the module. Check gap with feeler gauge and readjust if necessary. Refer to Figure 8-7.

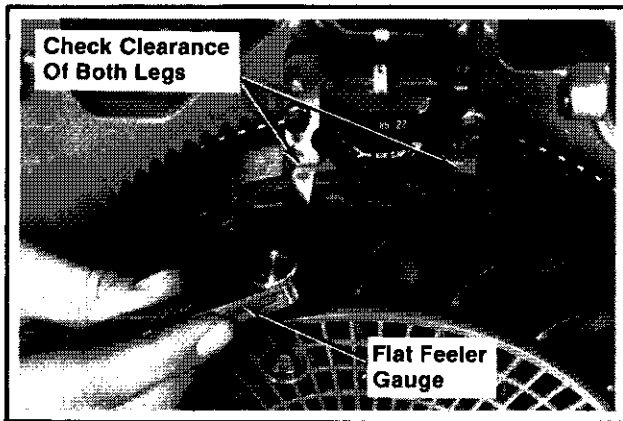

Figure 8-7. Checking Magnet-To-Module Air Gap.

6. Install the air baffle over module. Install the kill lead to kill terminal of module. Install high-tension lead and kill lead to slots in baffle.

Kill Lead With Optional Diode

An optional in-line diode is installed in the kill lead of some Magnum engines. This diode protects the module from burning out, in the event voltage is applied to the kill lead. Refer to Figure 8-8.

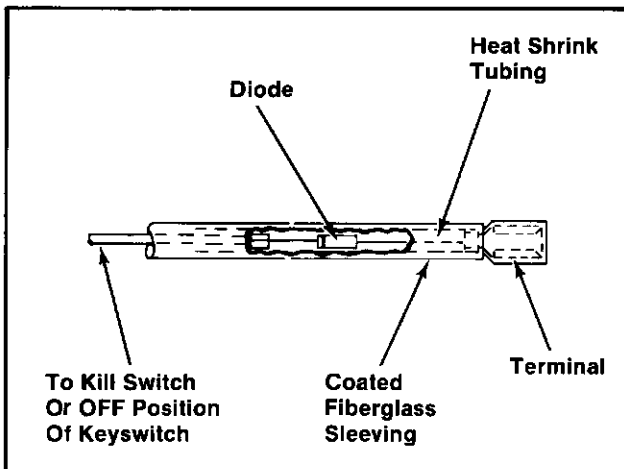

Figure 8-8. Kill Lead With In-line Diode.

The diode is rated such that diode failure (and subsequent module burn out) is highly unlikely. In the event a module with a diode protected kill lead does burn out, the diode should be tested.

DIODE TEST

Use an ohmmeter (or continuity tester) to test the diode.

1. Disconnect the kill lead terminals from the kill switch and ignition module.
2. Place the meter leads (or tester leads) across the kill lead.

In one direction, the resistance should be infinity ohms (open circuit - no continuity). Reverse the test leads; some resistance should be measured (closed circuit - continuity).

3. If the resistance is infinity ohms in both directions (no continuity), the kill lead or diode is open.

Cut the protective tubing to expose the leads of diode. Perform the resistance (or continuity) test in step 2 to the diode leads. This will confirm if the lead or the diode is at fault.

4. If the resistance is 0 ohms in both directions (continuity), the diode is shorted.

KILL LEAD/DIODE REPLACEMENT

When servicing the kill lead, the entire lead can be replaced or, just the portion containing the diode. Refer to the appropriate Parts Manual for lead part numbers.

Replacing the entire lead usually requires removing the bearing plate (refer to the "Disassembly" and "Reassembly" sections). Use the following procedure to replace just the portion of lead with diode.

1. Cut off the diode portion of kill lead approximately 4-3/4" from terminal.
2. Strip 1/4" of insulation from kill lead.
3. Crimp the "insulink" connector of replacement diode/lead assembly to kill lead.

Spark Plug

Engine misfire or starting problems are often caused by a spark plug in poor condition or with improper gap setting.

SERVICE

Every 100 operating hours remove the spark plug, check its condition, and reset gap or replace with new plug as necessary. Refer to Figure 8-9.

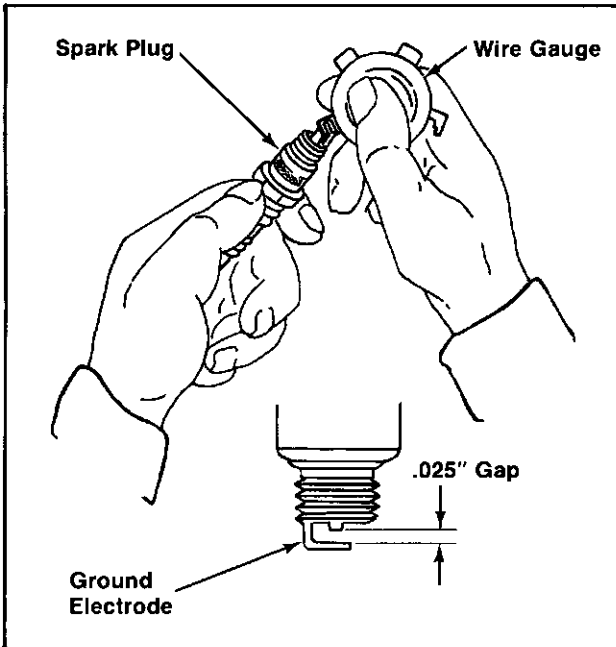

Figure 8-9. Servicing Spark Plug.

1. Before removing the spark plug, clean the area around the base of plug to keep dirt and debris out of the engine.
2. Remove the plug and check its condition. Replace the plug if it is worn or if reuse is questionable.

Use Champion® Type (or equivalent):

RCJ-8 — On Model M8

RH-10 — On Models M10, M12, M14, and M16

CAUTION: Do not clean the spark plug in a machine using abrasive grit. Some grit could remain in spark plug and enter the engine causing extensive wear and damage.

3. Check the gap using a wire feeler gauge. Adjust gap to **0.025"** by carefully bending the ground electrode.
4. Reinstall the spark plug into cylinder head.
Torque plug to **18/22 ft. lb.**

INSPECTION

Inspect the spark plug as soon as it is removed from the cylinder head. The deposits on the tip are an indication of the general condition of piston rings, valves, and carburetor.

Normal and faulty spark plugs are shown in the following photos.

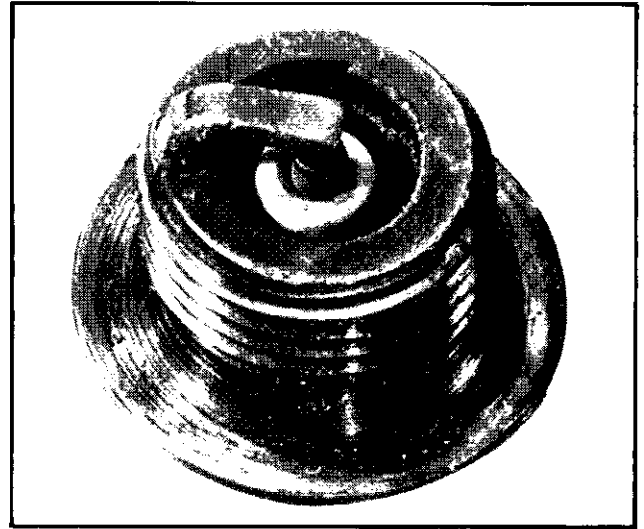

Normal: A plug taken from an engine operating under normal conditions will have light tan or gray colored deposits. If the center electrode is not worn, a plug in this condition could be regapped and reused.

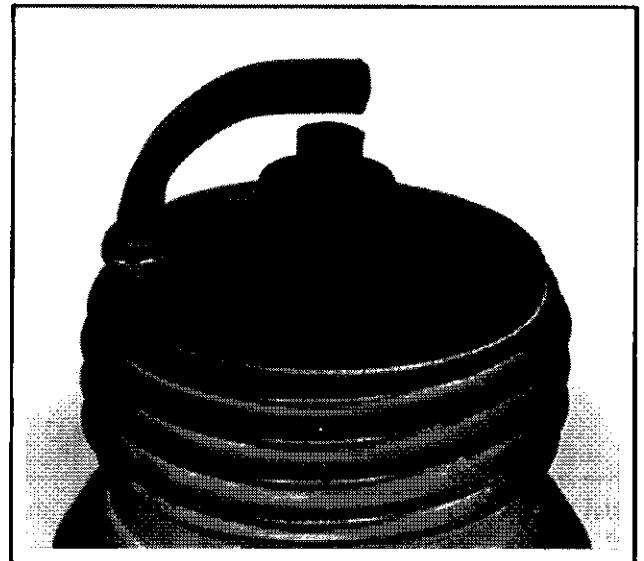

Carbon Fouled: Soft, sooty, black deposits indicate incomplete combustion. Incomplete combustion is usually caused by overrich carburetion, weak ignition, or poor compression.

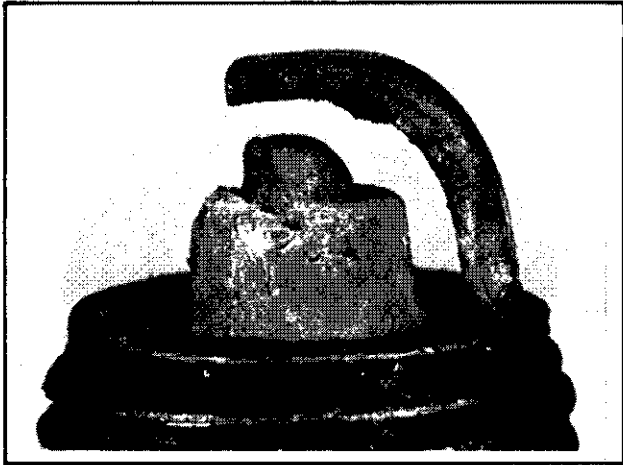

Worn: On a worn plug, the center electrode will be rounded and the gap will be eroded .010" or more than the correct gap. Replace a worn spark plug immediately.

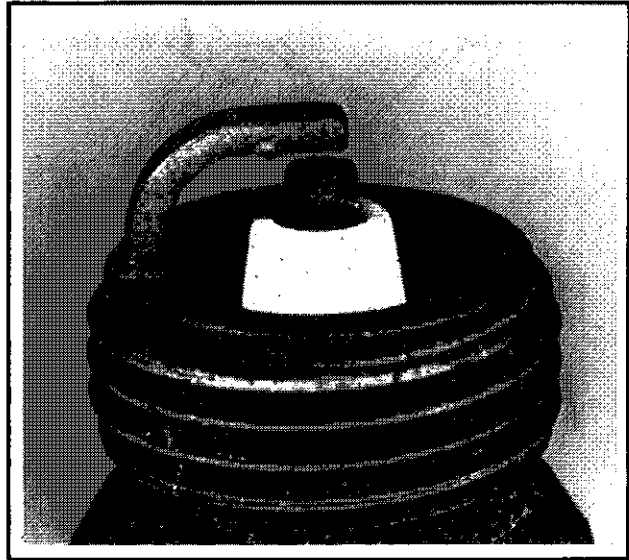

Chalky White Deposits: Chalky white colored deposits indicate overheating. This condition is usually accompanied by excessive gap erosion. A clogged grass screen, clogged cooling fins, and lean carburetion are some causes of over-heating.

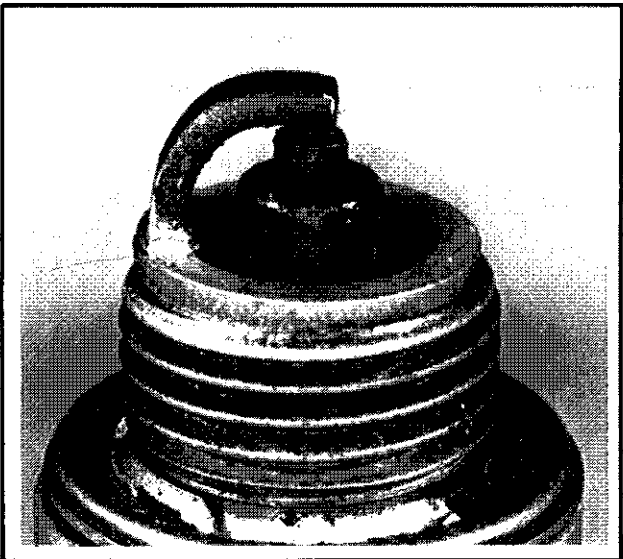

Wet Fouled: A wet plug is caused by excess fuel, or oil in the combustion chamber. Excess fuel could be caused by operating the engine with too much choke. Oil in the combustion chamber is usually caused by worn piston rings or valve guides.

ELECTRICAL SYSTEMS WIRING DIAGRAM AND BATTERY CHARGING SYSTEMS

The following lighting/battery charging systems are available on Magnum single cylinder engines.

- 70 Watt Lighting Stator
- 1.25 Amp Unregulated Battery Charging System
- 1.25 Amp Charging System/70 Watt Lighting
- 3 Amp Charging System/70 Watt Lighting
- 15 Amp Regulated Battery Charging System
- 25 Amp Regulated Battery Charging System

Refer to the following wiring diagrams and troubleshooting guides to test and service these lighting and battery charging systems.

CAUTION: To prevent damage to the electrical system and components:

1. Make sure battery polarity is correct. A negative (-) ground system is used.
2. Disconnect the rectifier-regulator leads and/or wiring harness plug before electric welding is done on the equipment powered by the engine. Also disconnect other electrical accessories in common ground with the engine.
3. Prevent the stator (AC) leads from touching or shorting. This could permanently damage the stator.

Manual Start Engines Optional 70 Watt Lighting

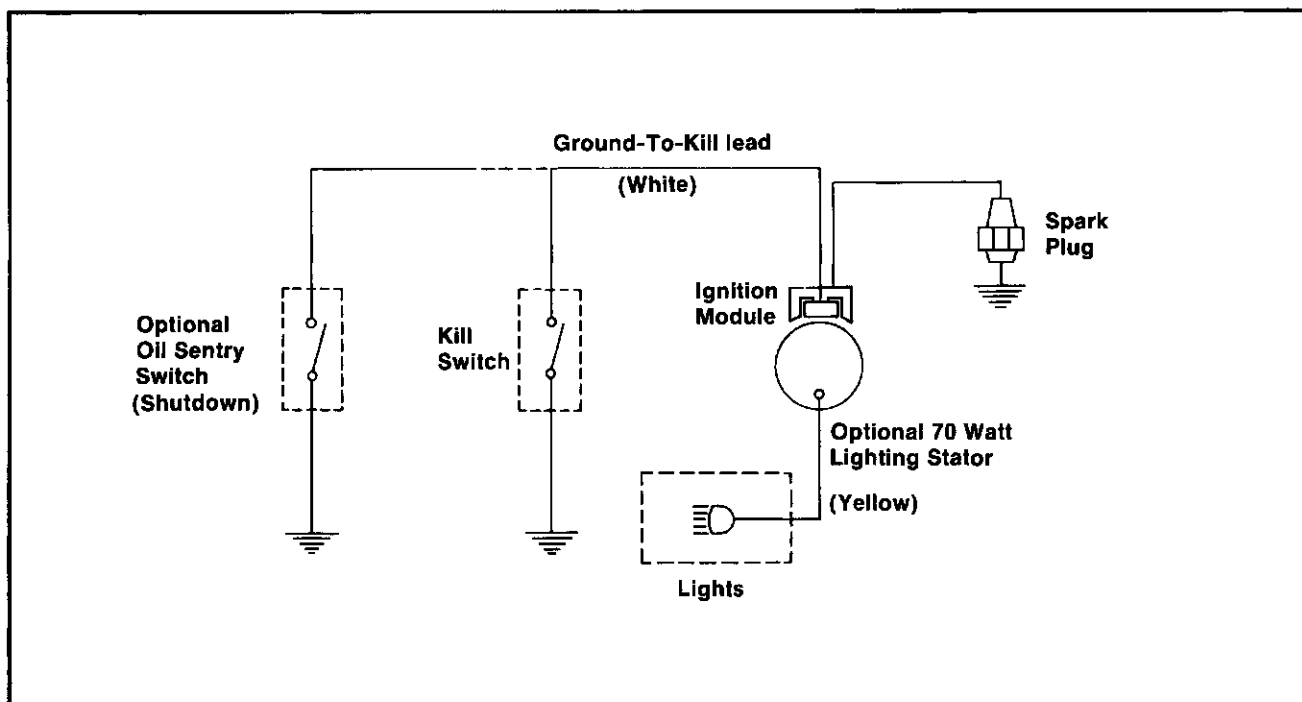

Figure 8-10. Wiring Diagram - Manual Start Engines/70 Watt Lighting.

Troubleshooting Guide 70 Watt Lighting Stator

NOTE: Zero ohmmeters and voltmeters on each scale to ensure accurate readings. Voltage tests should be made with engine running at 3200 RPM - no load.

Problem	Test	Conclusion
NO LIGHTS	1. Make sure lights are not burned out.	1. Replace burned out lights.
	2. Disconnect the lighting lead from the wiring harness. With engine running at 3200 RPM, measure voltage from lighting lead to ground using an AC voltmeter.	2. If voltage is 15 volts or more, stator is OK. Check for loose connections or shorts in wiring harness. If voltage is less than 15 volts, test stator using an ohmmeter (Test 3).
	3. With engine stopped, measure the resistance of stator from lighting lead to ground using an ohmmeter.	3. If resistance is 0.3/0.5 ohms, stator is OK. If resistance is 0 ohms, stator is shorted. Replace stator. If resistance is infinity ohms, stator or lighting lead is open. Replace stator.

Electric Start Engines
1.25 Amp Or 3 Amp Unregulated Charging System
Optional 70 Watt Lighting

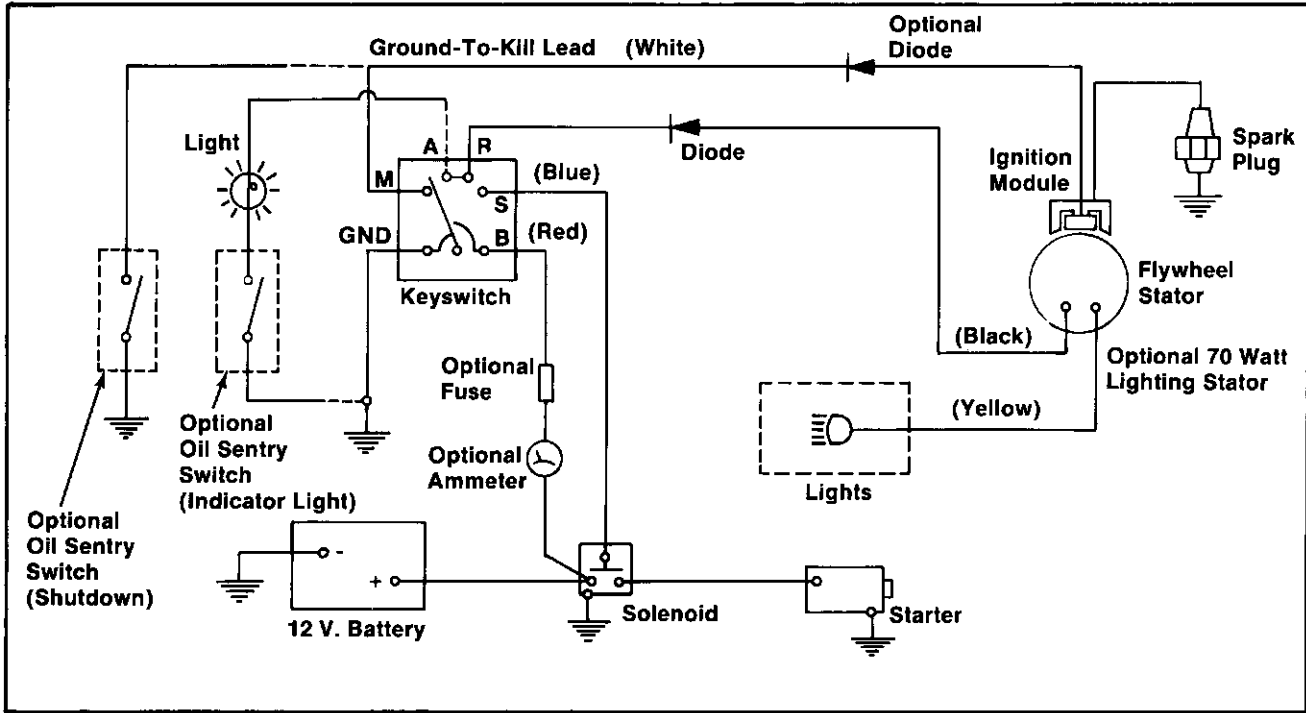

Figure 8-11. Wiring Diagram - Electric Start Engines/1.25 Amp Or 3 Amp Unregulated Battery Charging System/70 Watt Lighting.

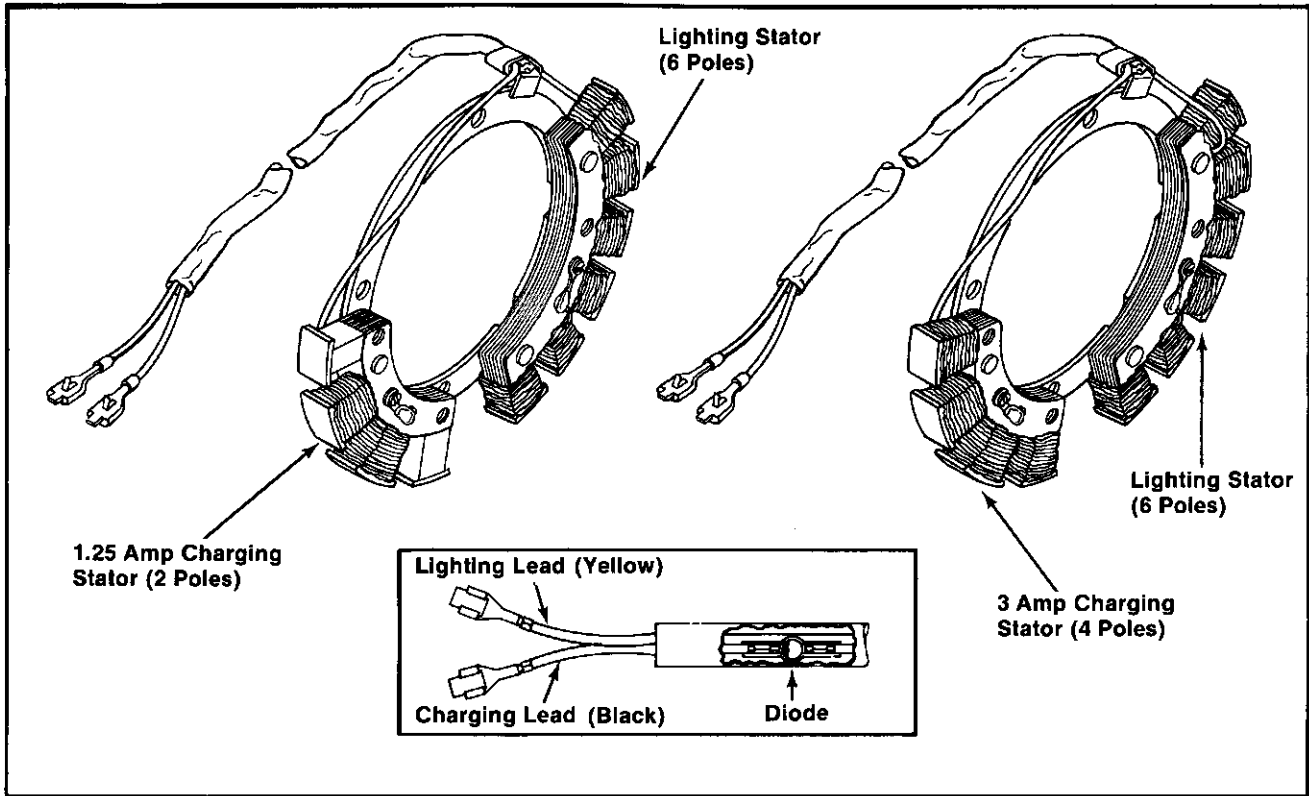

Figure 8-12. 1.25 Amp Or 3 Amp Stator/70 Watt Lighting Stator.

Troubleshooting Guide

1.25 Amp Battery Charging System

NOTE: Zero ohmmeters and voltmeters on each scale to ensure accurate readings. Voltage tests should be made with engine running at 3200 RPM - no load. Battery must be fully charged.

Problem	Test	Conclusion
NO CHARGE TO BATTERY	1. With engine running at 3200 RPM, measure voltage across battery terminals using a DC voltmeter.	1. If voltage is more than 12.5 volts, charging system is OK. If voltage is 12.5 volts or less, the stator or diode are probably faulty. Test the stator and diode (Test 2, 3, and 4).
	2. Disconnect the charging lead from battery. With engine running at 3200 RPM, measure voltage from charging lead to ground using a DC voltmeter.	2. If voltage is 11.5 volts or more, stator winding is OK. If voltage is less than 11.5 volts, test stator using an ohmmeter (Tests 3 and 4).
	3. With charging lead disconnected from battery and engine stopped, measure resistance from charging lead to ground using an ohmmeter. Note reading. Reverse the leads and measure resistance again. In one direction, the resistance should be infinity ohms (open circuit). With the leads reversed, some resistance should be measured (about midscale on Rx1 range).	3. If resistance is low in both directions, the diode is shorted. Replace the diode. If resistance is high in both directions, the diode or stator winding is open. (Use test 4).
	4. Cut the sleeving on the charging lead to expose the diode connections. Measure the resistance from the stator side of diode to ground using an ohmmeter.	4. If resistance is 0.7/1.3 ohms, stator winding is OK. If resistance is 0 ohms, stator winding is shorted. Replace stator. If resistance is infinity ohms, stator winding or lead is open. Replace stator.

Troubleshooting Guide

3 Amp Battery Charging System With 70 Watt Lighting Stator

NOTE: Zero ohmmeters and voltmeters on each scale to ensure accurate readings. Voltage tests should be made with engine running at 3000 RPM - no load. Battery must be fully charged.

Problem	Test	Conclusion
NO CHARGE TO BATTERY	1. With engine running at 3000 RPM, measure voltage across battery terminals using a DC voltmeter.	1. If voltage is more than 12.5 volts, charging system is OK. If voltage is 12.5 volts or less, the stator or diode are probably faulty. Test the stator and diode (Test 2, 3, and 4).
	2. Disconnect the charging lead from battery. With engine running at 3000 RPM, measure voltage from charging lead to ground using a DC voltmeter.	2. If voltage is 28 volts or more, stator winding is OK. If voltage is less than 28 volts, test stator using an ohmmeter (Tests 3 and 4).
	3. With charging lead disconnected from battery and engine stopped, measure resistance from charging lead to ground using an ohmmeter. Note reading. Reverse the leads and measure resistance again. In one direction, the resistance should be infinity ohms (open circuit). With the leads reversed, some resistance should be measured (about midscale on Rx1 range).	3. If resistance is low in both directions, the diode is shorted. Replace the diode. If resistance is high in both directions, the diode or stator winding is open. (Use Test 4).
	4. Cut the sleeving on the charging lead to expose the diode connections. Measure the resistance from the stator side of diode to ground using an ohmmeter.	4. If resistance is approx. 1.07 ohms, stator winding is OK. If resistance is 0 ohms, stator winding is shorted. Replace stator. If resistance is infinity ohms, stator winding or lead is open. Replace stator.
NO LIGHTS	1. Make sure lights are not burned out	1. Replace burned out lights.
	2. Disconnect the lighting lead from the wiring harness. With engine running at 3000 RPM, measure voltage from lighting lead to ground using an AC voltmeter.	2. If voltage is 15 volts or more, stator is OK. Check for loose connections or shorts in wiring harness. If voltage is less than 15 volts, test stator using an ohmmeter (Test 3).
	3. With engine stopped, measure the resistance of stator from lighting lead to ground using an ohmmeter.	3. If resistance is approx. 0.4 ohms, stator is OK. If resistance is 0 ohms, stator is shorted. Replace stator. If resistance is infinity ohms, stator or lighting lead is open. Replace stator.

Electric Start Engines 15 Amp Regulated Charging System

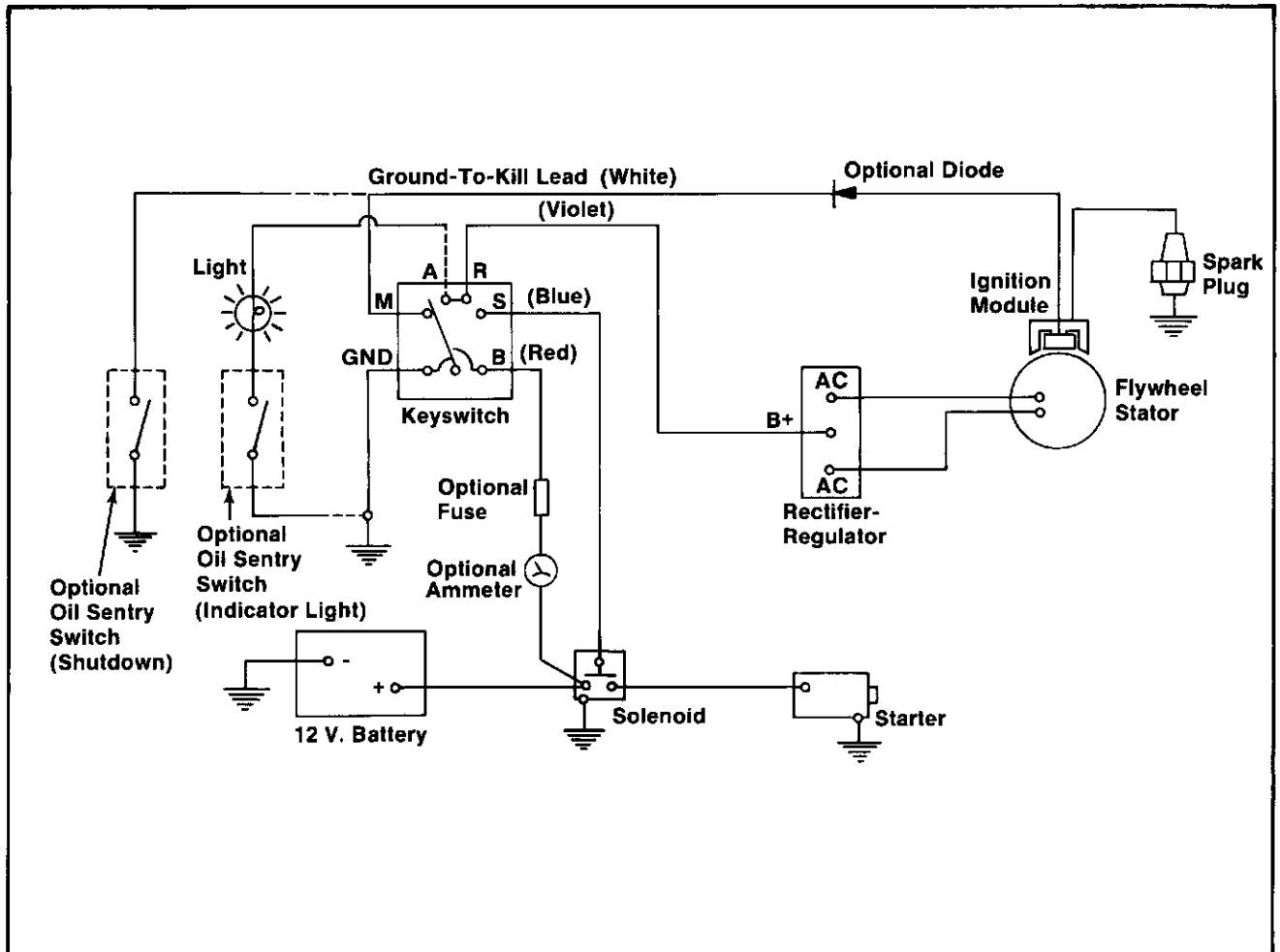

Figure 8-13. Wiring Diagram - Electric Start Engines/15 Amp Regulated Battery Charging System.

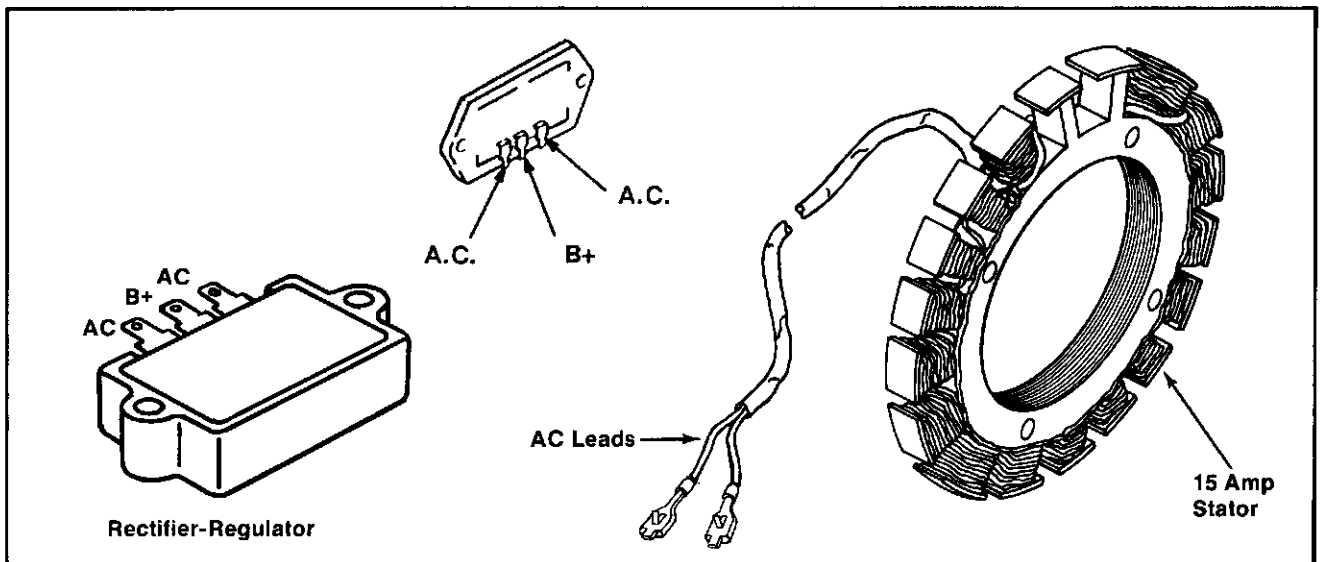

Figure 8-14. 15 Amp Stator And Rectifier-Regulator.

Troubleshooting Guide

15 Amp Battery Charging System

NOTE: Zero ohmmeters and voltmeters on each scale to ensure accurate readings. Voltage tests should be made with engine running at 3600 RPM - no load. Battery must be fully charged.

Problem	Test	Conclusion
No Charge To Battery	1. Insert an ammeter in B+ lead from rectifier-regulator. With engine running at 3600 RPM and B+ (at terminal on rectifier-regulator) to ground using a DC voltmeter. If voltage is 13.8 volts or more, place a minimum load of 5 Amps* on battery to reduce voltage. Observe ammeter. *NOTE: Turn on lights, if 60 watts or more. Or place a 2.5 ohm, 100 watt resistor across battery terminals.	1. If charge rate increases when load is applied, the charging system is OK and battery was fully charged. If charge rate does not increase when load is applied, test stator and rectifier-regulator (tests 2 and 3).
	2. Remove connector from rectifier-regulator. With engine running at 3600 RPM, measure AC voltage across stator leads using an AC voltmeter.	2. If voltage is 28 volts or more, stator is OK. Rectifier-regulator is faulty. Replace the rectifier-regulator. If voltage is less than 28 volts, stator is probably faulty and should be replaced. Test stator further using an ohmmeter (test 3).
	3a. With engine stopped, measure the resistance across stator leads using an ohmmeter.	3a. If resistance is 0.1/0.2 ohms, the stator is OK. If resistance is 0 ohms, the stator is shorted. Replace stator. If resistance is infinity ohms, stator is open. Replace stator.
	3b. With engine stopped, measure the resistance from each stator lead to ground using an ohmmeter.	3b. If resistance is infinity ohms (no continuity), the stator is OK (not shorted to ground). If resistance (or continuity) is measured, the stator leads are shorted to ground. Replace stator.
Battery Continuously Charges At High Rate	1. With engine running at 3600 RPM, measure voltage from B+ lead to ground using a DC voltmeter.	1. If voltage is 14.7 volts or less the charging system is OK. The battery is unable to hold charge. Service battery or replace as necessary. If voltage is more than 14.7 volts, the rectifier-regulator is faulty. Replace rectifier-regulator.

**Electric Start Engines
25 Amp Regulated Charging System**

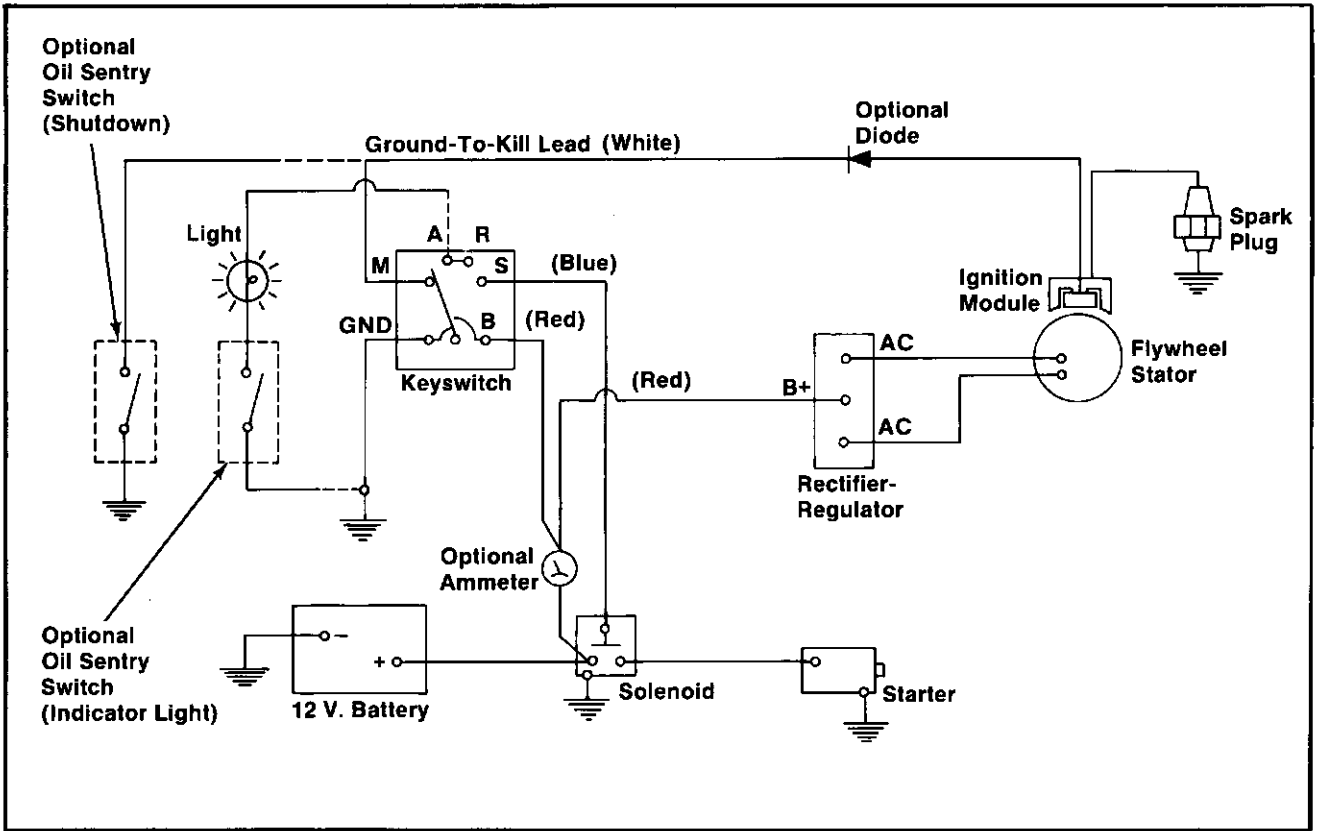

Figure 8-15. Wiring Diagram - Electric Start Engines/25 Amp Regulated Battery Charging System.

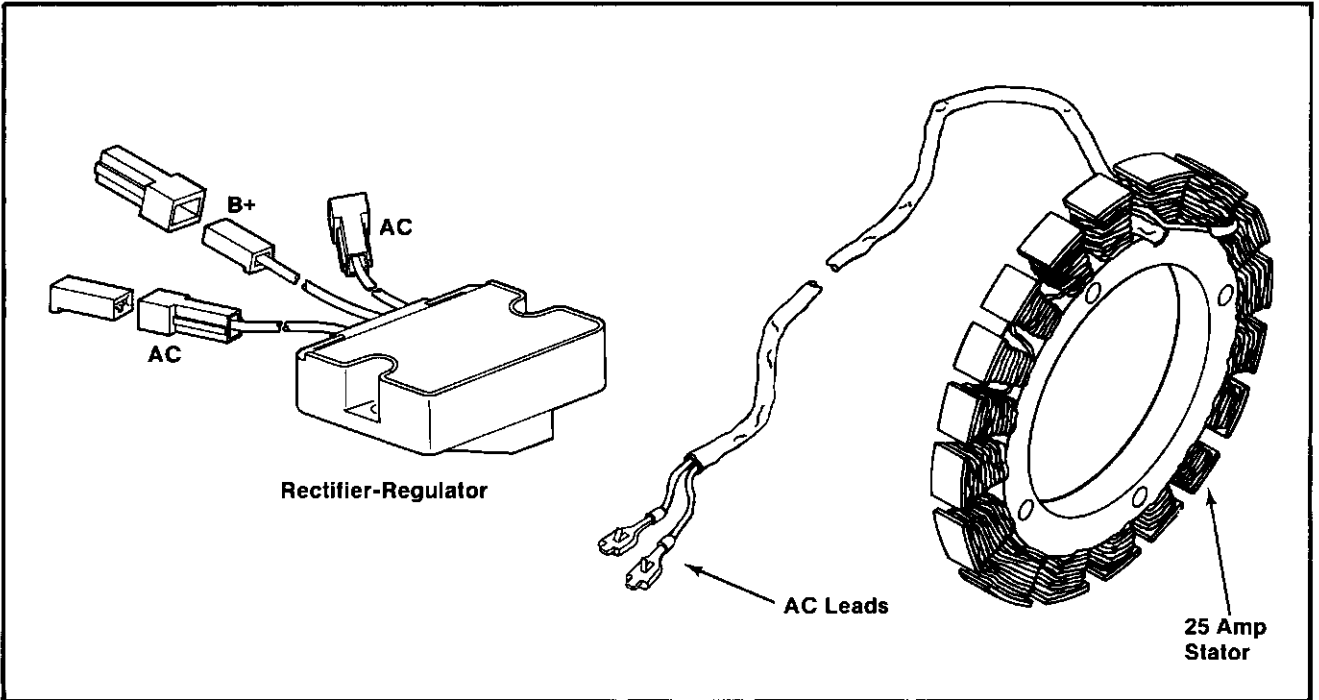

Figure 8-16. 25 Amp Stator And Rectifier-Regulator.

Troubleshooting Guide

25 Amp Battery Charging System

NOTE: Zero ohmmeters and voltmeters on each scale to ensure accurate readings. Voltage tests should be made with engine running at 3600 RPM - no load. Battery must be fully charged.

Problem	Test	Conclusion
No Charge To Battery	1. Insert an ammeter in B+ lead from rectifier-regulator. With engine running at 3600 RPM and B+ (at terminal on rectifier-regulator) to ground using a DC voltmeter. If voltage is 13.8 volts or more, place a minimum load of 5 Amps* on battery to reduce voltage. Observe ammeter. *NOTE: Turn on lights, if 60 watts or more. Or place a 2.5 ohm, 100 watt resistor across battery terminals.	1. If charge rate increases when load is applied, the charging system is OK and battery was fully charged. If charge rate does not increase when load is applied, test stator and rectifier-regulator (tests 2 and 3).
	2. Remove connector from rectifier-regulator. With engine running at 3600 RPM, measure AC voltage across stator leads using an AC voltmeter.	2. If voltage is 28 volts or more, stator is OK. Rectifier-regulator is faulty. Replace the rectifier-regulator. If voltage is less than 28 volts, stator is probably faulty and should be replaced. Test stator further using an ohmmeter (test 3).
	3a. With engine stopped, measure the resistance across stator leads using an ohmmeter.	3a. If resistance is 0.064/0.096 ohms, the stator is OK. If resistance is 0 ohms, the stator is shorted. Replace stator. If resistance is infinity ohms, stator is open. Replace stator.
	3b. With engine stopped, measure the resistance from each stator lead to ground using an ohmmeter.	3b. If resistance is infinity ohms (no continuity), the stator is OK (not shorted to ground). If resistance (or continuity) is measured, the stator leads are shorted to ground. Replace stator.
Battery Continuously Charges At High Rate	1. With engine running at 3600 RPM, measure voltage from B+ lead to ground using a DC voltmeter.	1. If voltage is 14.7 volts or less the charging system is OK. The battery is unable to hold charge. Service battery or replace as necessary. If voltage is more than 14.7 volts, the rectifier-regulator is faulty. Replace rectifier-regulator.

BATTERY

Batteries are supplied by the equipment manufacturer. A 12-volt battery with a rating of at least 32 amp. hr./250 is recommended. Refer to the equipment manufacturer's instructions for specific information.

Battery Test

If the battery charge is not sufficient to crank the engine, recharge the battery

CAUTION: Do not attempt to "jump start" the engine with another battery. Starting the engine with batteries larger than those recommended can burn out the starter motor.

Test the battery voltage by connecting D.C. voltmeter across the battery terminals — crank the engine. If the battery drops below 9 volts while cranking, the battery is discharged or faulty. Refer to Figure 8-17.

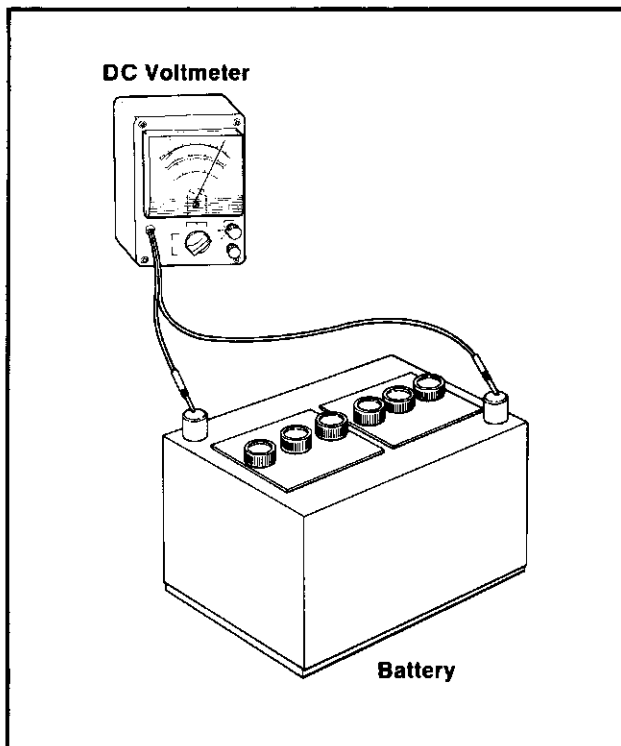

Figure 8-17. Checking Battery Voltage.

Battery Charging

WARNING: Dangerous Acid, Explosive Gases!
Batteries contain sulphuric acid. To prevent acid burns, avoid contact with skin, eyes, and clothing.



Batteries produce explosive hydrogen gas while being charged. Charge the battery in well ventilated areas. Keep cigarettes, sparks, open flame, and other sources of ignition away from battery at all times.

To prevent accidental shorting and the resulting sparks, remove all jewelry when servicing the battery.

When disconnecting battery cables, always disconnect the negative (-) (ground) cable first. When connecting battery cables, always connect the negative cable last.

Before disconnecting the negative (-) ground cable, make sure all switches are OFF. If ON, a spark will occur at the ground cable terminal which could cause an explosion if hydrogen gas or gasoline vapors are present.

Keep batteries and acid out of the reach of children.

Battery Maintenance

Regular maintenance will ensure the battery will accept and hold a charge.

1. Regularly check the level of electrolyte. Add **distilled** water as necessary to maintain the recommended level.

CAUTION: Do not overfill the battery. Poor performance or early failure due to loss of electrolyte will result.

2. Keep the cables, terminals, and external surfaces of battery clean. A build-up of corrosive acid or grime on the external surfaces can self-discharge the battery. Self-discharging happens rapidly when moisture is present.

Wash the cables, terminals, and external surfaces with a baking soda and water solution. Rinse thoroughly with clean water.

CAUTION: Do not allow the baking soda solution to enter the cells as this will destroy the electrolyte.

KEYSWITCH

The keyswitch used on Magnum engines equipped with instrument panels is shown in Figure 8-18. It is a three position (OFF, RUN, START), break-before-make type switch.

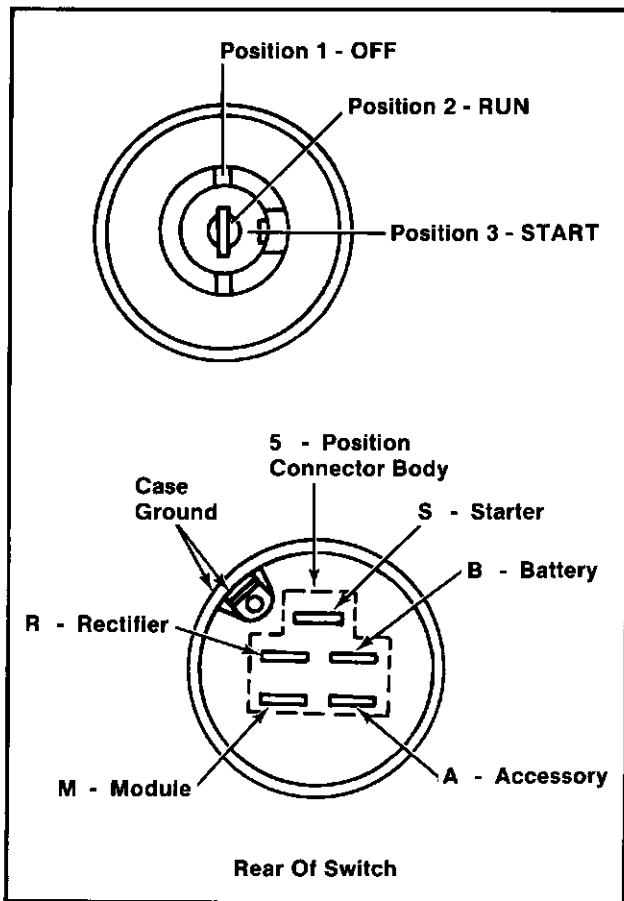

Figure 8-18. Keyswitch.

Testing

Test the switch for continuity using an ohmmeter or continuity test light. For each switch position, continuity should be present across the terminals listed in the table below.

Switch Position	Continuity Across Terminals
1 - OFF	G + M + A
2 - RUN	B + A + R
3 - START	B + S

SOLENOID

A solenoid is used on electric start engines equipped with an instrument panel or keyswitch. The solenoid is an electrically-actuated normally open switch designed for heavy current loads. Refer to Figure 8-19.

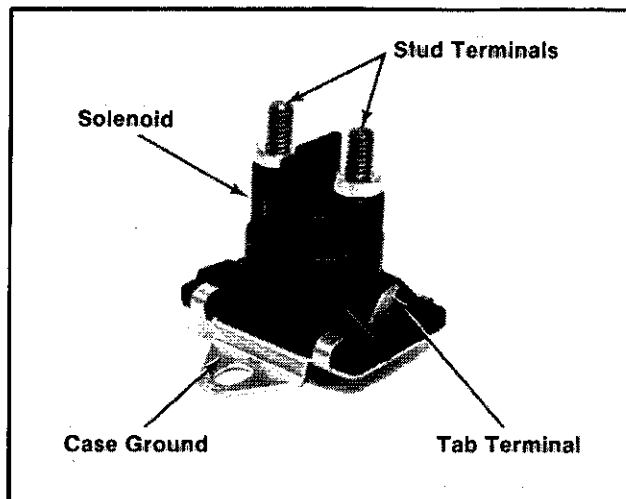

Figure 8-19. Starter Solenoid.

The solenoid is used to switch the heavy current required by the starter using the keyswitch (designed for low current loads).

Testing

1. Connect an ohmmeter or continuity tester across the stud terminals of solenoid.
2. Apply 12 volts DC across the tab terminal and case ground of solenoid and observe ohmmeter or tester.

NOTE: Apply positive (+) of voltage supply to tab terminal; negative (-) to case ground.

3. The ohmmeter or tester should indicate continuity as long as voltage is applied. If there is no continuity, the solenoid is probably faulty and should be replaced.

Check the solenoid further using an ohmmeter (step 4).

4. Measure the resistance of the coil in the solenoid using an ohmmeter. Connect one meter lead to the case ground and one lead to the tab terminal.

If the resistance is 5.2/6.3 ohms, the coil is OK.

If the resistance is low or 0 ohms, the coil is shorted. Replace the solenoid.

If the resistance is infinity ohms, the coil is open. Replace solenoid.

ELECTRIC STARTER

These engines use a permanent magnet, bendix-drive electric starter. Refer to Figure 8-20.

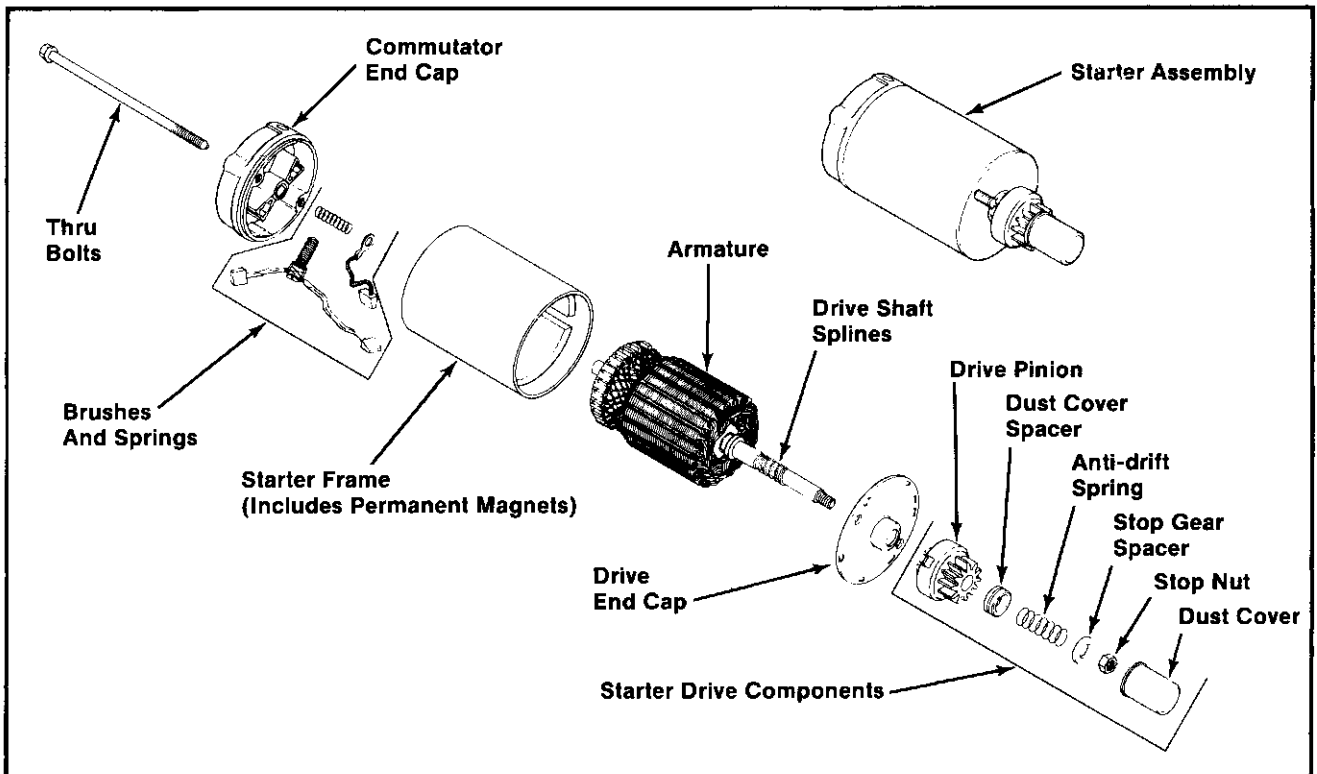

Figure 8-20. Bendix Drive Electric Starter.

Operation

When power is applied to the starter, the armature rotates. As the armature rotates, the drive pinion moves out on the splined drive shaft into mesh with the flywheel ring gear. When the pinion reaches the end of the drive shaft, it rotates the flywheel cranking the engine.

When the engine starts, the flywheel rotates faster than the armature and drive pinion. This moves the drive pinion out of mesh with the ring gear and into the retracted position. When power is removed from the starter, the armature stops rotating and the pinion is held in the retracted position by the anti-drift spring.

CAUTION: Do not crank the engine continuously for more than 10 seconds at a time. If the engine does not start, allow a 60 second cool-down period between starting attempts. Failure to follow these guidelines can burn out the starter motor.

CAUTION: If the engine develops sufficient speed to disengage the starter but does not keep running (a "false start"), the engine rotation must be allowed to come to a complete stop before attempting to restart the engine. If the starter is engaged while the flywheel is rotating, the starter pinion and flywheel ring gear may clash. This can damage the starter.

CAUTION: If the starter does not crank the engine, shut off the starter immediately. Do not make further attempts to start the engine until the condition is corrected. Do not jump start using another battery. Using batteries larger than those recommended can burn out the starter motor.

CAUTION: Do not drop the starter or strike the starter frame. Doing so can damage the ceramic permanent magnets.

Troubleshooting Guide

Problem	Possible Fault	Correction
STARTER FAILS TO ENERGIZE	Wiring	1. Clean corroded connections and tighten loose connections. 2. Replace wires in poor condition and with frayed or broken insulation.
	Starter Switch or Solenoid	Bypass the switch or solenoid with a jumper wire — if starter cranks normally, replace the faulty parts.
	Battery	Check specific gravity of battery. If low, recharge or replace battery as necessary.
STARTER ENERGIZES BUT TURNS SLOWLY	Battery	Check specific gravity of battery. If low, recharge or replace battery as necessary.
	Brushes	Check for excessively dirty or worn brushes and commutator. Clean using a coarse cloth (not emery paper). Replace brushes if excessively or unevenly worn.
	Transmission Or Engine	Make sure the clutch or transmission is disengaged or placed in neutral. This is especially important on equipment with hydrostatic drive. The transmission must be exactly in neutral to prevent resistance which could keep the engine from starting. Check for seized engine components such as the bearings, connecting rod, and piston.

Starter Removal And Installation

Refer to the appropriate "Disassembly" and "Reassembly" sections for starter removal and installation procedures.

CAUTION: When the thru bolts are removed from the bearing plate and starter, the drive end cap and commutator end cap can separate from the starter frame.

To prevent the starter from becoming completely disassembled, make sure the end caps are taped and held securely against starter frame when removing the thru bolts. Reinstall the thru bolts and temporarily secure with 1/4-20 hex nuts to keep starter assembled.

Starter Drive Service

Every 500 operating hours or annually (whichever occurs first), clean and lubricate the drive splines of the starter. If the drive pinion is badly worn, or has chipped or broken teeth, it must be replaced.

It is not necessary to disassemble the starter to service the drive components. Refer to Figure 8-20 and service drive as follows:

1. Hold the drive pinion in a vise with soft jaws when removing and installing the stop nut. The armature will rotate with the nut only until the drive pinion stops against internal spacers.
CAUTION: Do not overtighten the vise as this can distort the drive pinion.
2. Remove the dust cover, stop nut, stop gear spacer, anti-drift spring, dust cover spacer, and drive pinion.
3. Clean the drive shaft splines with solvent. Dry the splines thoroughly.
4. Apply a small amount of Kohler electric starter drive lubricant (Part No. 52 357 01) to splines.
CAUTION: Kohler starter drive lubricant (Part No. 52 357 01) must be used on all Kohler electric starter drives. The use of other lubrications can cause the drive to stick or bind.
5. Apply a small amount of Loctite® No. 271 to stop nut threads.
6. Reinstall the drive pinion, dust cover spacer, anti-drift spring, stop gear spacer, and stop nut. Torque stop nut to **160 in. lb.** Install the dust cover.

Disassembly

1. Remove the dust cover, stop nut, stop gear spacer, anti-drift spring, dust cover spacer, and drive pinion. Refer to "Starter Drive Service."
2. Remove the temporary nuts and thru bolts.
3. Remove the drive end cap and thrust washer.
4. Remove the commutator end cap with brushes and springs.
5. Remove the armature from inside the starter frame.

Brush Replacement (Refer to Figure 8-21)

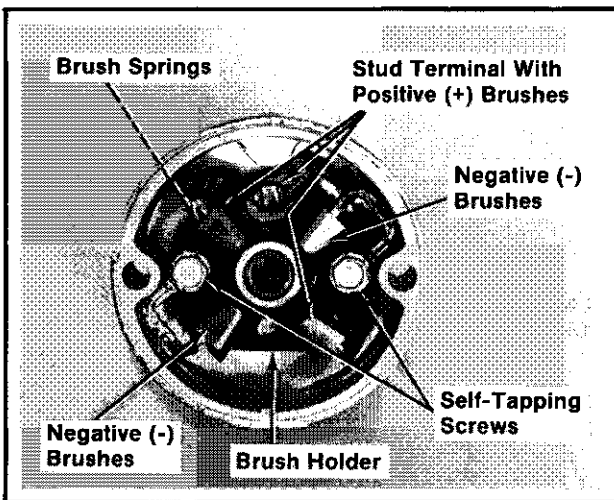

Figure 8-21. Commutator End Cap With Brushes.

1. Remove the brush springs from the pockets in brush holder.
2. Remove the self-tapping screws and negative (-) brushes.
3. Remove hex nut, split lock washer, plain washer, and fiber washer from the stud terminal.

Remove the stud terminal with positive (+) brushes, and plastic brush holder from end cap.

4. Reinstall the brush holder and new stud terminal with positive (+) brushes into end cap. Secure with the fiber washer, plain washer, split lock washer, and hex nut.

CAUTION: To prevent electric arcing, make sure the stud terminal and braided brush leads do not touch the end cap.

5. Install the new negative (-) brushes and secure with the self-tapping screws.

6. Install the brush springs and brushes into the pockets in brush holder. Make sure the chamfered sides of brushes are away from the springs.

NOTE: Use a brush holder tool to keep the brushes in the pockets. A brush holder tool can easily be made from thin sheet metal. Refer to Figure 8-22.

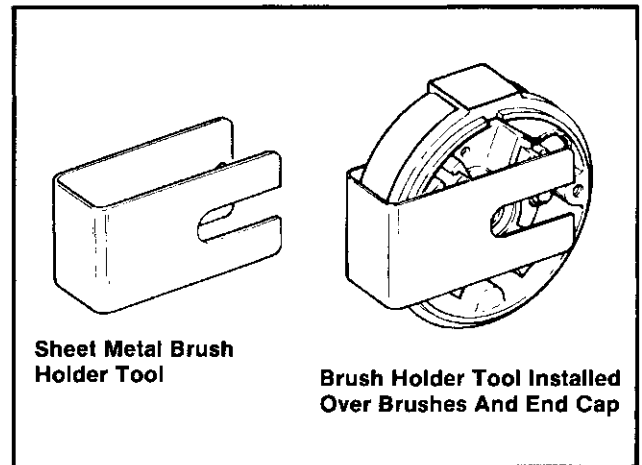

Figure 8-22. Brush Holder Tool

Commutator Service

Clean the commutator with a coarse, lint free cloth. Do not use emery cloth. If the commutator is badly worn or grooved, turn down on a lathe, or replace the armature.

Reassembly

1. Insert the armature into the starter frame. Make sure the magnets are closer to the drive shaft end of armature. The magnets will hold the armature inside the frame.
2. Install the thrust washer and drive end cap. Make sure the match marks on end cap and frame are aligned. Refer to Figure 8-23.

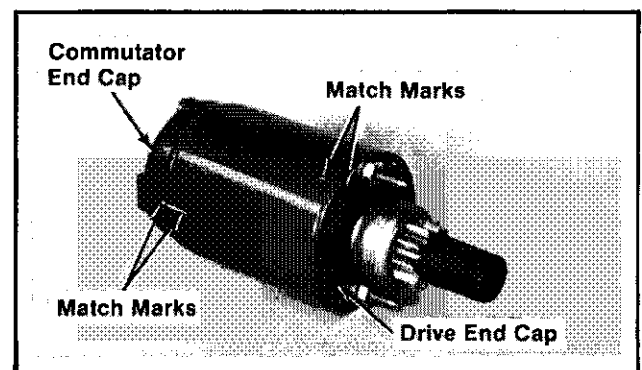

Figure 8-23. Starter Assembly Match Marks

3. Install the brush holder tool to keep the brushes in the pockets of commutator end cap. Refer to Figure 8-22.
4. Install the commutator end cap to armature and starter frame. Firmly hold the drive end cap and commutator end cap to the starter frame. Remove the brush holder tool.
5. Make sure the match marks on end cap and frame are aligned. Refer to Figure 8-23. Install the thru bolts and temporary nuts to keep the starter assembled.
6. Install the drive pinion, dust cover spacer, anti-drifting spring, stop gear spacer, stop nut, and dust cover. Refer to "Starter Drive Service."

**OIL SENTRY™
OIL LEVEL MONITOR**



Operation

Some engines are equipped with optional Oil Sentry system. Oil Sentry uses a float switch in the oil pan to detect a low engine oil level. On stationary or unattended applications (pumps, generators, etc.) the float switch can be used to ground the ignition module to stop the engine. On vehicular applications (garden tractors, mowers, etc.) and those equipped with a battery or electric start, the float switch can be used to activate a "low oil" warning light.

NOTE: Refer to the Specifications in the "General Information" section for maximum angles of operation for engines equipped with Oil Sentry. Always operate the engine within the guidelines specified. Operating the engine at angles greater than specified could cause the engine to stop if wired for low oil shut off.

The following instructions will enable switch removal, installation, and testing without removing the oil pan. Follow these instructions carefully to prevent damage to the switch.

Float Switch Removal

1. Make sure the engine/equipment is resting on a level surface.
2. Remove the oil drain plug and drain oil from crankcase.
3. Disconnect float switch leads.

4. Using a 9/16" open end wrench, turn switch counterclockwise 1/4 TURN to loosen. STOP turning switch when flat surface on float switch is in a horizontal position. (Flat surface parallel with base of oil pan and N.C./N.O. markings down.) Refer to Figures 8-24 and 8-25.

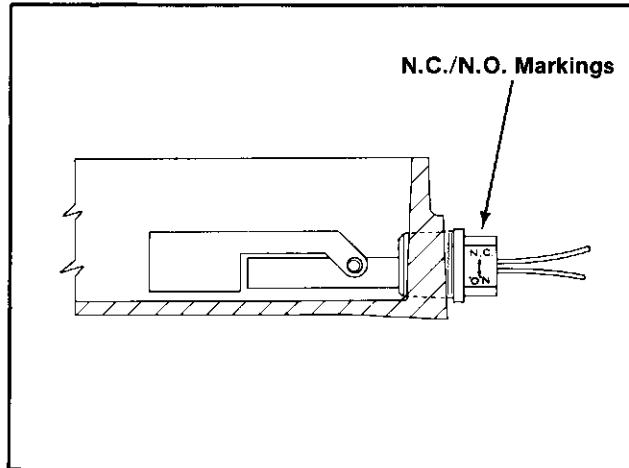

Figure 8-24. Float Switch Removal.

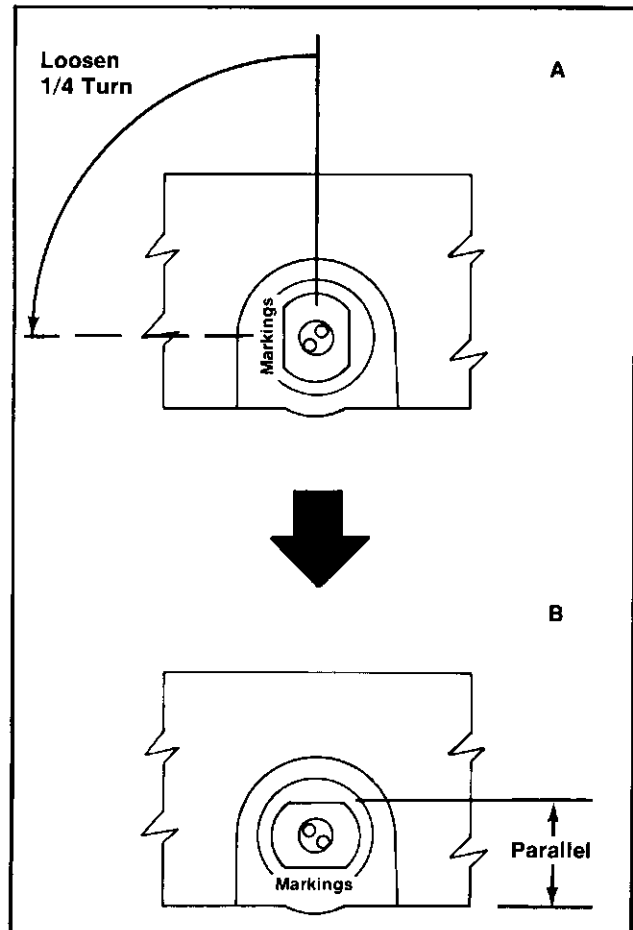

Figure 8-25. Float Switch Removal.

5. Turn the switch counterclockwise in 1/2 TURN INCREMENTS using a smooth, continuous action. Pause briefly between increments and keep the flat surface of float switch in a horizontal position (parallel with base of oil pan). Refer to Figure 8-26.

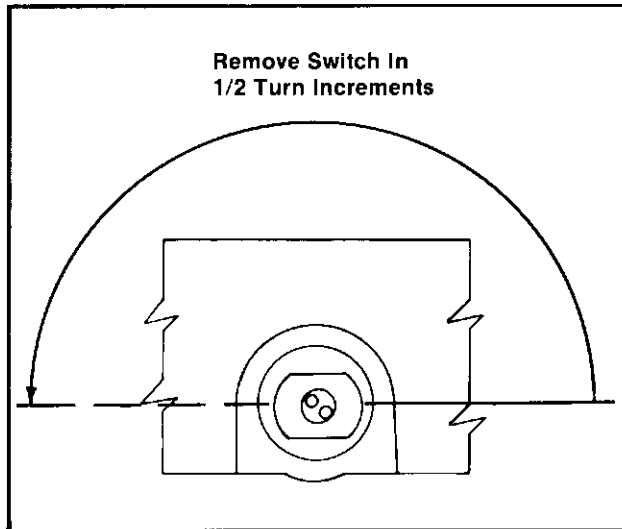

Figure 8-26. Float Switch Removal.

CAUTION: To prevent damage to the float switch, and to enable you to “feel” if the float strikes the oil pan, REMOVE THE SWITCH BY HAND as soon as it is loose enough for you to do so.

When turning the float switch, use a smooth, continuous action for the ENTIRE 1/2 turn increment. Pausing the rotation of the switch in the position shown in Figure 8-27 will cause the float to strike the oil pan.

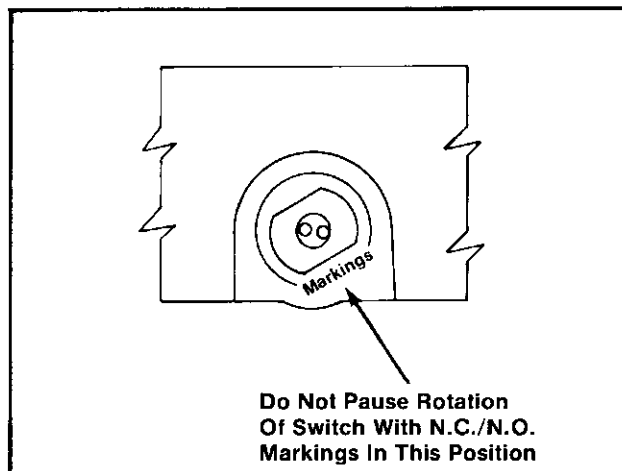

Figure 8-27. Float Switch Removal.

If the float does strike the oil pan, STOP turning the switch, then use the following procedure.

- A. Turn the switch clockwise until the flat surface is in a vertical position as shown in Figure 8-25A. (N.C./N.O. markings on left.) This will allow the float to return against the switch body.
- B. Turn the switch counterclockwise 1/4 TURN. STOP turning switch when flat surface is in a horizontal position. (Flat surface parallel with base of oil pan and N.C./N.O. markings down.) Refer to Figure 8-25B.
- C. Turn the switch counterclockwise in 1/2 TURN INCREMENTS as instructed in step 5 above.

Float Switch Installation

1. Make sure the engine/equipment is resting on a level surface.
2. Remove the oil drain plug and drain oil from crankcase.
3. When adding this switch as an accessory, remove and discard the 1/2" NPSF pipe plug from the location in oil pan where switch will be installed.

CAUTION: To prevent damage to the float switch, and to enable you to “feel” if the float strikes the oil pan, INSTALL THE SWITCH BY HAND as long as it is loose enough for you to do so.

4. Apply Locite® No. 592 Teflon® sealant (or equivalent) to the entire thread area of switch.
5. Apply a thick film of clean SAE 30 oil to the float and switch body as shown in Figure 8-28.

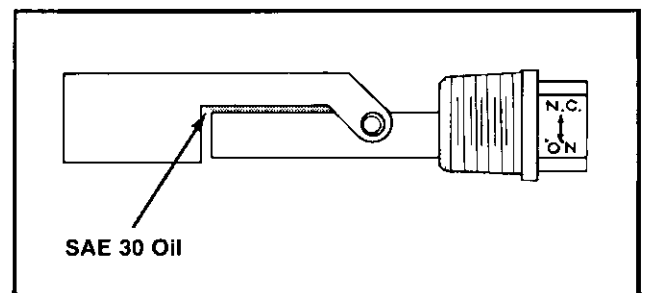

Figure 8-28. Float Switch Removal.

6. Hold the switch with the flat surface in a vertical position. (N.C./N.O. markings to the left.) Insert the switch into the oil pan and turn the switch 1/4 turn. STOP turning the switch when the flat surface on switch is in a horizontal position. Flat surface parallel with base of oil pan and N.C./N.O. markings up.) Refer to Figures 8-29A and 8-29B.

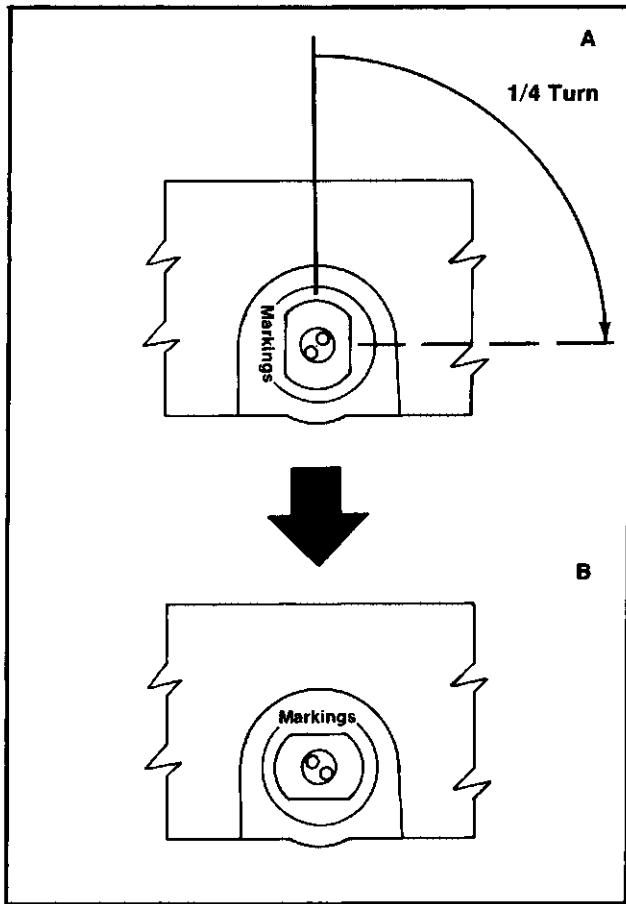

Figure 8-29. Float Switch Installation.

7. Turn the switch clockwise in 1/2 TURN INCREMENTS using a smooth continuous action. Pause briefly between increments and keep the flat surface of switch in a horizontal position (parallel with base of oil pan.) Refer to Figure 8-30.

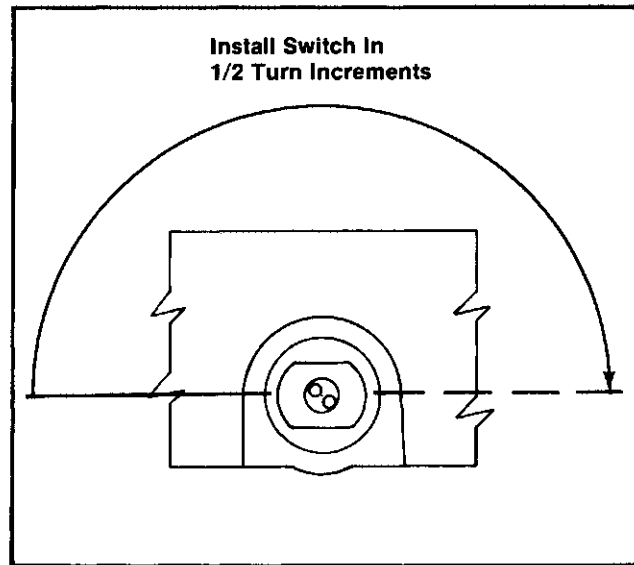

Figure 8-30. Float Switch Installation.

NOTE: Several "1/2 turn increments" may be required until the threads on switch engage in oil pan.

CAUTION: When turning the float switch, use a smooth continuous action for the entire 1/2 turn increment. Pausing the rotation of the switch in the position shown in Figure 8-31 will cause the float to strike the oil pan.

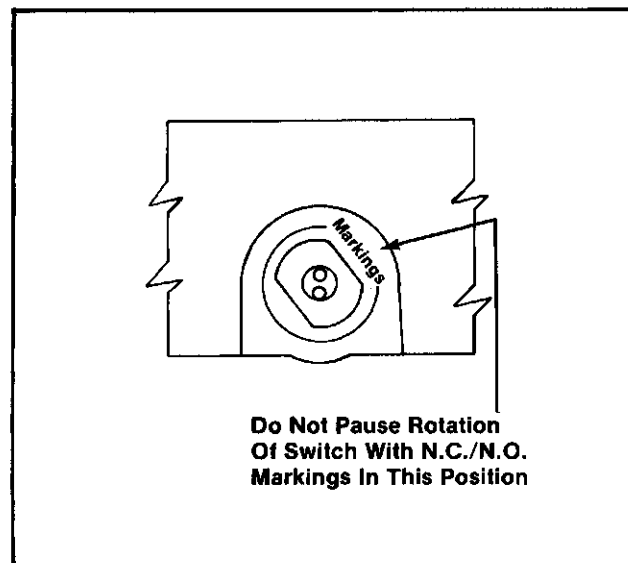

Figure 8-31. Float Switch Installation.

If the float does strike the oil pan, STOP turning the switch, then use the following procedure.

- A. Turn the switch counterclockwise until the flat surface is in a vertical position, (N.C./N.O. markings on left.) This will allow the float to return against the switch body. Refer to Figure 8-29A.
- B. Turn the switch clockwise 1/4 TURN. STOP turning switch when flat surface is in a horizontal position. (Flat surface parallel with base of oil pan and N.C./N.O. markings up.) Refer to Figure 8-29B.
- C. Turn the switch clockwise in 1/2 TURN INCREMENTS as instructed in step 7 above.

8. Turn in the switch approximately five (5) to six (6) full turns to obtain the proper position. Use a 9/16" open end wrench to tighten the switch. The "N.C." markings on switch will be at the top when the switch is positioned properly as shown in Figure 8-32.

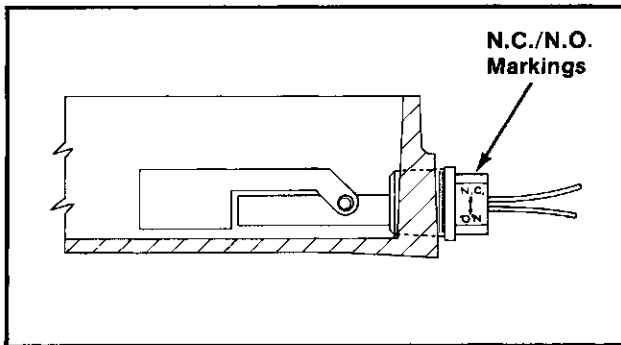

Figure 8-32. Float Switch Installation,

Float Switch Test

Test switch for continuity by placing an ohmmeter or continuity test light across leads. Refer to Figure 8-33.

Switch Position	Continuity
A	No (Switch open)
B	Yes (Switch closed)

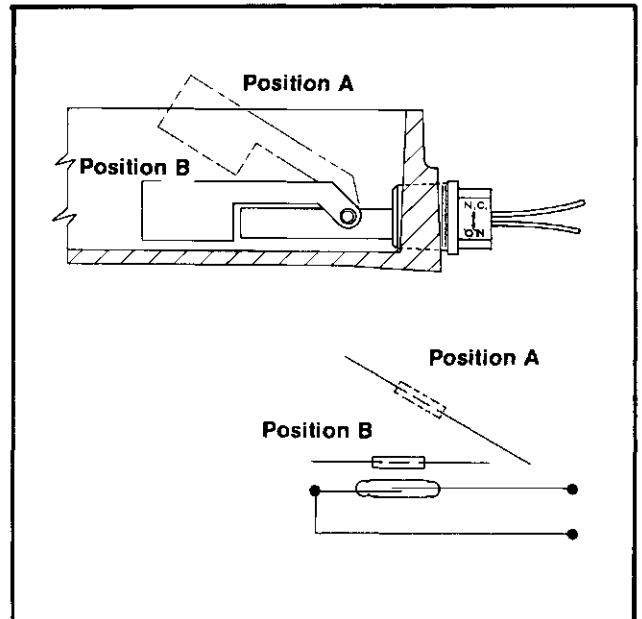

Figure 8-33. Float Switch Test.

Perform the following tests to ensure that the float switch is positioned and working properly before connecting the leads.

NOTE: These test apply to engines equipped with a standard oil pan and dipstick. Special oil pan and/or dipstick arrangements can give inaccurate test results.

1. Connect a continuity test light across float switch leads. The light **should be "on"**.
2. Install oil drain plug and refill crankcase with oil. The light **should be "off"** after oil is above the "L" mark on the dipstick.
3. If the float switch fails this test:
 - A. Make sure the switch is in the proper position with the "N.C." markings at the top. Refer to Figure 8-32.
 - B. If switch is positioned properly, drain oil and remove switch (see "Float Switch Removal"). If the float is not attached to the switch body, the oil pan must be removed.
 - C. Replace a faulty or broken switch with a new one. (See "Float Switch Installation".)

Operational Test

Reconnect the leads and perform the following test.

1. Make sure the oil level is up to, but not over the "F" mark on dipstick.

2. Start the engine.

If the switch is wired as a low oil level shutdown, the engine should start.

If the switch is wired to activate a low oil warning light, the light should be "off."

3. Stop the engine. Drain the oil until the oil level is below the "L" mark on dipstick. If properly wired, the engine will not start, or the light will be "on".

4. If the test results of steps 2 and 3 are not as indicated, check for improper wiring and/or improper float installation.

SECTION 9

MAGNUM

Single Cylinder Engine
Service Manual
Models M8, M10, M12
M14, M16
TP-2203-A 3/86

KOHLER
engines

AUTOMATIC COMPRESSION RELEASE

All Magnum single cylinder engines are equipped with Automatic Compression Release (ACR). The ACR mechanism lowers compression at cranking speeds to make starting easier.

OPERATION

The ACR mechanism consists of two flyweights and a spring attached to the gear on camshaft. When the engine is rotating at low cranking speeds (600 RPM or lower) the flyweights are held by the spring in the position shown in Figure 9-1.

In this position, the tab on the larger flyweight protrudes above the exhaust cam lobe. This lifts the exhaust valve off of its seat during the first part of the compression stroke. The reduced compression results in an effective compression ratio of about 2:1 during cranking.

After the engine speed increases to about 600 RPM, centrifugal force moves the flyweights to the position shown in Figure 9-2. In this position the tab on the larger flyweight drops into the recess in the exhaust cam lobe. When in the recess, the tab

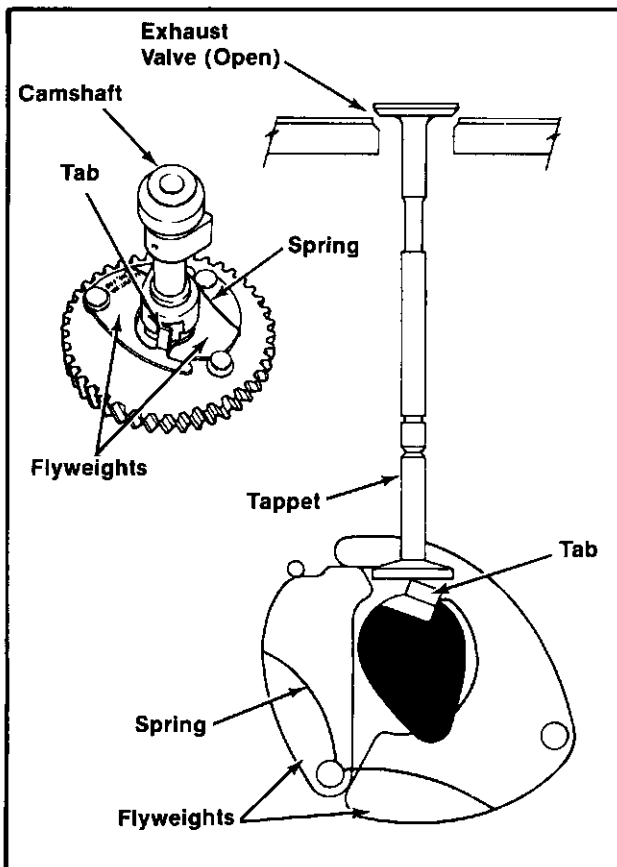

Figure 9-1. Automatic Compression Release (ACR) - Starting Position.

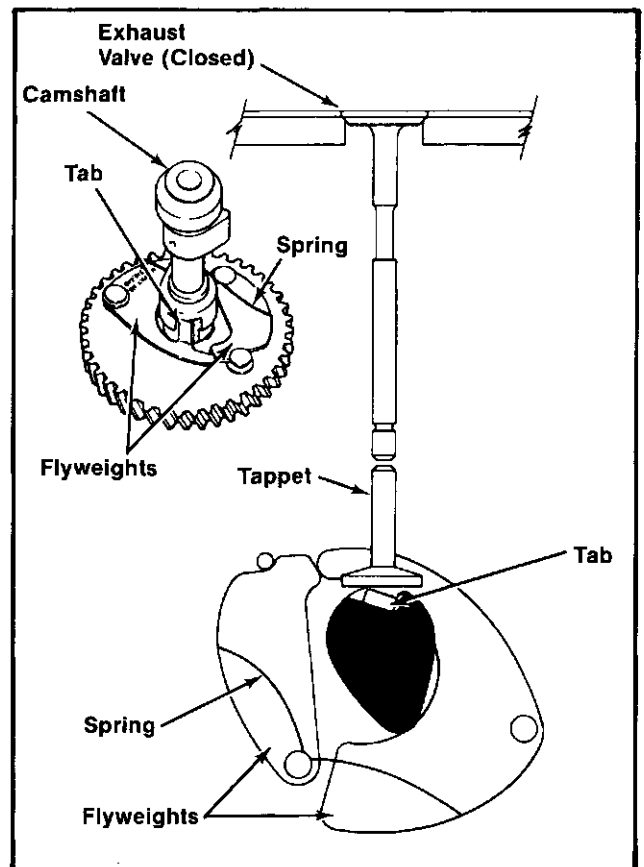

Figure 9-2. Automatic Compression Release (ACR) - Running Position.

has no effect on the exhaust valve and the engine operates at full compression and full power.

When the engine is stopped, the spring returns the flyweights to the position shown in Figure 9-1, ready for the next start.

BENEFITS

Because of the reduced compression pressures at cranking speeds, several important benefits are obtained.

- Manual starting (rope start or retractable start) is much easier. Without ACR, manual starting at full compression would be virtually impossible.
- Electric start models can use a starter and battery size that are practical for the applications in which these engines are used.
- ACR eliminates the need for a spark retard/advance mechanism. A spark retard/advance mechanism would be required on engines without ACR to prevent “kickback” that occurs when starting. ACR eliminates this “kickback” making manual starting safer.
- The choke control setting is less critical, and in the event of flooding, excess fuel is blown out of the lifted exhaust valve and does not hamper starting.
- Engines with ACR start much faster in cold weather than those without ACR.
- Engines with ACR can be started with spark plugs that are worn or fouled. Engines without ACR probably could not be started with those same plugs.

INSPECTION AND SERVICE

The ACR mechanism is extremely rugged and virtually troublefree. If hard starting is experienced, check the exhaust valve for lift as follows:

1. Check exhaust valve to tappet clearance and adjust as necessary to specification.
2. Remove cylinder head and turn the crankshaft clockwise by hand and observe the exhaust valve carefully.

When the piston is approx. 2/3 of the way up the cylinder during the compression stroke, the exhaust valve should lift off the seat slightly.

If the exhaust valve does not lift, the ACR spring may be unhooked or broken. To service the spring, remove the oil pan and rehook the

spring or replace it. The camshaft does not have to be removed.

The flyweights are not serviceable. If they are stuck or worn excessively, the camshaft must be replaced.

CAUTION: The tab on the flyweights is hardened and is not adjustable. Do not attempt to bend the tab—it will break and a new camshaft will be required.

COMPRESSION TESTING

Because of the ACR mechanism, it is difficult to obtain an accurate compression reading.

To check the condition of the combustion chamber, and related mechanisms, physical inspection and a crankcase vacuum test are recommended.

SECTION 10A

MAGNUM

Single Cylinder Engine
Service Manual

Models M8, M10, M12
M14, M16

TP-2203-A 3/86

KOHLER
engines

MODEL M8 DISASSEMBLY PROCEDURE

WARNING: Accidental Starts!



Before servicing the engine or equipment, always remove the spark plug lead to prevent the engine from starting accidentally. Ground the lead to prevent sparks that could cause fires.

The following sequence is suggested for complete engine disassembly. This procedure may have to be varied slightly to accommodate options or special equipment.

Clean all parts thoroughly as the engine is disassembled. Only clean parts can be accurately inspected and gauged for wear or damage. There are many commercially available cleaners that quickly remove grease, oil, and grime from engine parts. When such a cleaner is used, follow the manufacturer's instructions carefully. Make sure all traces of the cleaner are removed before the engine is reassembled and placed in operation—even small amounts of these cleaners quickly break down the lubricating properties of engine oil.

1. Disconnect spark plug lead.
2. Drain oil from crankcase.
3. Remove air cleaner.
4. Remove muffler.
5. Remove rectifier/regulator.
6. Remove choke linkage, throttle linkage, and carburetor.
7. Remove fuel pump.
8. Remove external governor components, and throttle and choke controls.
9. Remove retractable starter.
10. Remove electric starter and solenoid.
11. Remove fuel tank.
12. Remove cylinder head baffle, blower housing, and side air baffles.

13. Remove breather assembly.
14. Remove spark plug and cylinder head.
15. Remove ignition module and air baffle.
16. Remove drive cup or rope start pulley, grass screen, flywheel, and fan.
17. Remove stator.
18. Remove valves.
19. Remove oil pan.
20. Remove connecting rod and piston.
21. Remove piston from connecting rod.
22. Remove piston rings.
23. Remove crankshaft and bearing plate.
24. Remove camshaft and tappets.
25. Remove governor gear and cross shaft.
26. Remove oil seals.
27. Remove bearings.

DISCONNECT SPARK PLUG LEAD DRAIN OIL FROM CRANKCASE REMOVE AIR CLEANER

1. Remove the wing nut and air cleaner cover. Refer to Figure 10A-1.

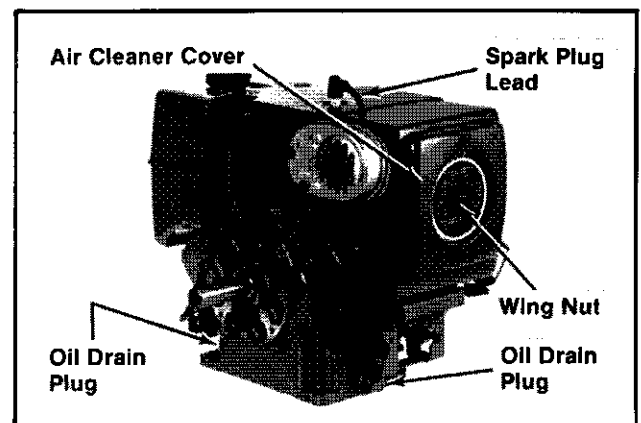

Figure 10A-1. Removing Spark Plug Lead, Oil Drain Plug, And Air Cleaner Cover

- Remove the precleaner (if so equipped), element cover nut, element cover, paper element, and seal. Refer to Figures 10A-2 and 10A-3.

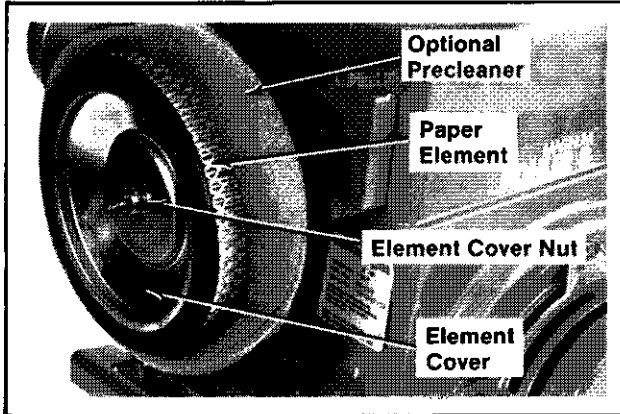

Figure 10A-2. Removing Air Cleaner Element.

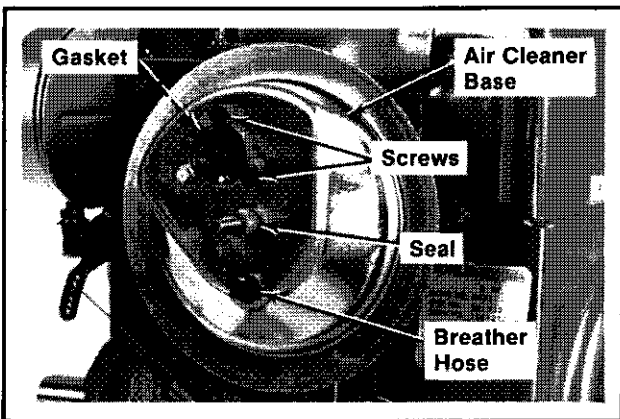

Figure 10A-3. Removing Air Cleaner Base.

- Remove the screws, air cleaner base, gasket, and breather hose.

REMOVE MUFFLER

- Remove cap screws, muffler, gasket, and heat shield. Refer to Figure 10A-4.

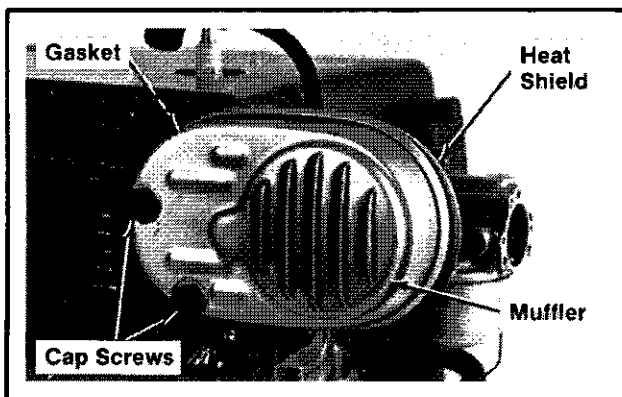

Figure 10A-4. Removing Muffler.

REMOVE RECTIFIER-REGULATOR

Refer to Figure 10A-5.

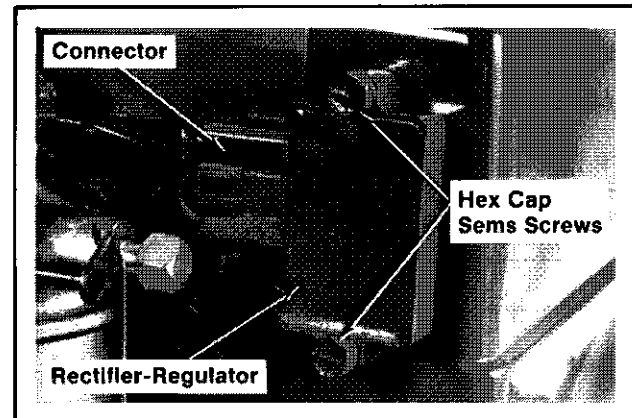

Figure 10A-5. Removing Rectifier-Regulator.

- Remove the hex cap sems screws and rectifier-regulator.
- Remove the connector from rectifier-regulator.

REMOVE CHOKE LINKAGE, THROTTLE LINKAGE, AND CARBURETOR

WARNING: Explosive Fuel!



Gasoline may be present in carburetor and fuel system. Gasoline is extremely flammable, and its vapors can explode if ignited. Keep cigarettes, sparks, open flames, and other sources of ignition away from the engine. Wipe up spilled fuel immediately.

- Remove the wing nut, plain washer, choke lever, and choke linkage. (Reinstall choke lever, plain washer, and wing nut after removing linkage.) Refer to Figure 10A-6.
- Close the fuel shut-off valve at fuel tank (if so equipped) or drain fuel from tank.
- Loosen the hose clamp, and remove fuel line at carburetor.
- Remove the slotted hex cap sems screws, carburetor, throttle linkage, and gasket.

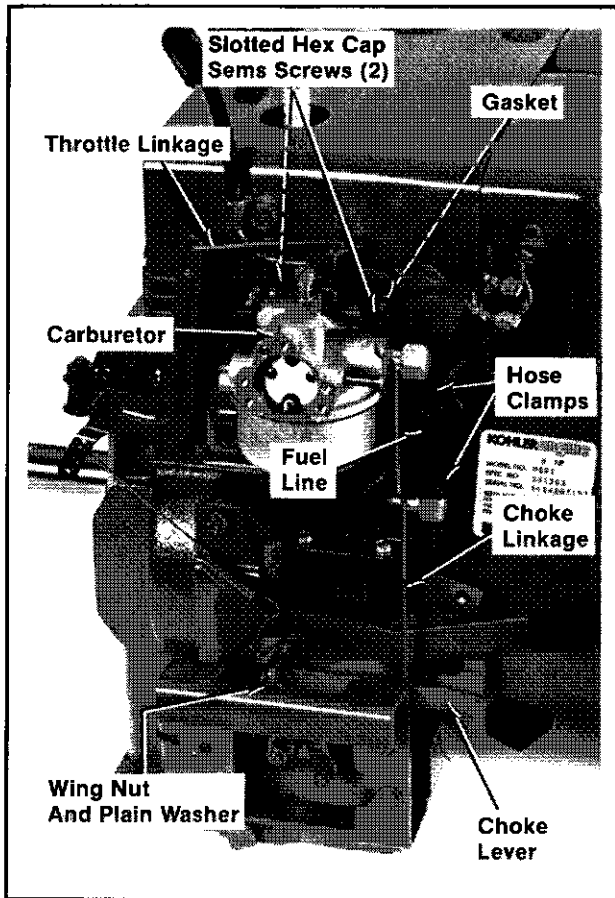

Figure 10A-6. Removing Choke Linkage, Throttle Linkage, And Carburetor.

REMOVE FUEL PUMP

WARNING: Explosive Fuel!



Gasoline may be present in fuel pump and fuel system. Gasoline is extremely flammable, and its vapors can explode if ignited. Keep cigarettes, sparks, open flames, and other sources of ignition away from engine. Wipe up spilled fuel immediately.

1. Disconnect the fuel line from fuel pump inlet fitting. Refer to Figure 10A-7.
2. Remove the fillister head sems screws, plain washer, fuel pump, and gasket.

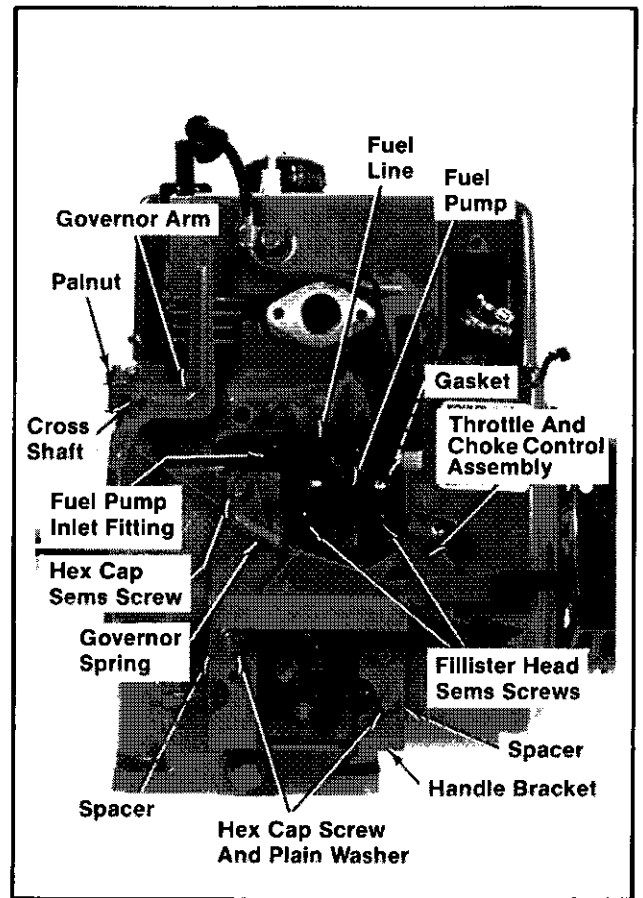

Figure 10A-7. Removing Fuel Pump, External Governor Components, And Throttle and Choke Controls.

REMOVE EXTERNAL GOVERNOR COMPONENTS, AND THROTTLE AND CHOKE CONTROLS

Refer to Figure 10A-7.

1. Note the position of the governor spring in governor arm.
2. Loosen the palnut and remove governor arm from cross shaft. Remove the governor spring.

NOTE: Loosening palnut or removing governor arm will disrupt governor arm to cross shaft adjustment. Readjustment will be required upon reassembly.

3. Remove the hex cap sems screw, hex cap screws, plain washers, and spacers.
4. Remove the throttle and choke control assembly from handle bracket and engine crankcase.
5. Disconnect the lead from engine kill switch (if so equipped).

REMOVE RETRACTABLE STARTER

1. Remove the screws and starter assembly. Refer to Figure 10A-8.

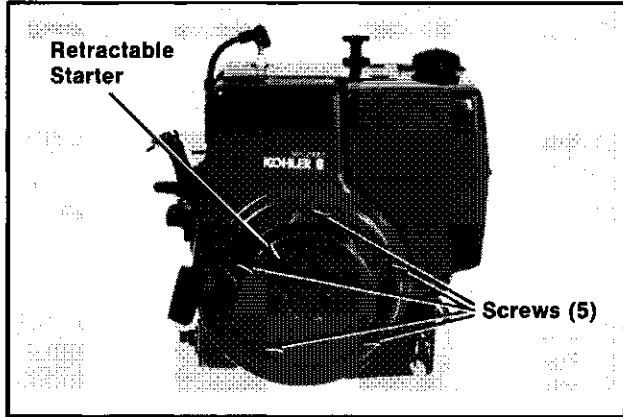

Figure 10A-8. Removing Retractable Starter.

REMOVE ELECTRIC STARTER AND SOLENOID

1. Remove the lead from stud terminal of electric starter. Refer to Figure 10A-9.

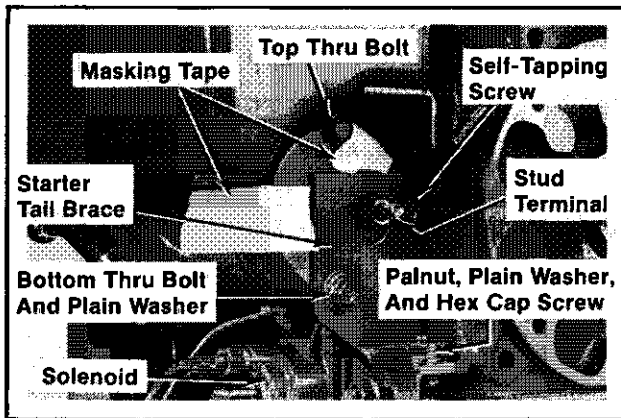

Figure 10A-9. Removing Starter Tail Brace And Starter.

2. Remove the palnut, plain washer, and hex cap screw from starter tail brace.
3. Place masking tape across the commutator end cap and frame.
4. Remove the bottom thru bolt, plain washer, self-tapping screw, and starter tail brace.
5. Hold the commutator end cap against frame, and carefully remove top thru bolt. Remove starter from bearing plate. Refer to Figure 10A-10.

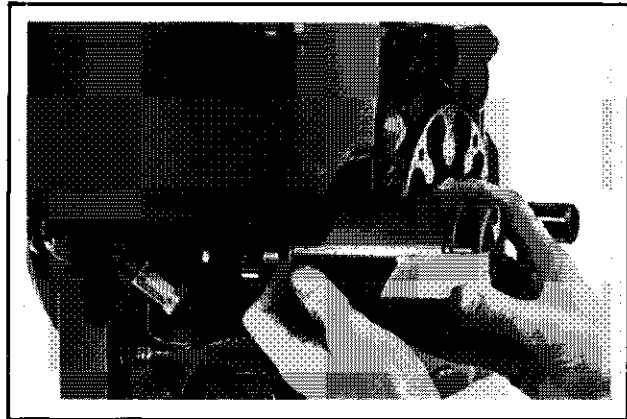

Figure 10A-10. Removing Starter From Bearing Plate.

CAUTION: The starter may become disassembled if the end caps are not taped or held against the frame.

6. Reinstall the thru bolts and two 1/4-20 hex nuts to keep starter assembled during remaining engine disassembly.
7. Remove the leads from solenoid. Remove the palnuts, screws, and solenoid from bracket.

REMOVE FUEL TANK

WARNING: Explosive Fuel!



Gasoline may be present in fuel tank and fuel system. Gasoline is extremely flammable, and its vapors can explode if ignited. Keep cigarettes, sparks, open flames, and other sources of ignition away from engine. Wipe up spilled fuel immediately.

1. Remove the fuel line from tank outlet fitting.
2. Remove the hex cap screws, truss head screws, and fuel tank with bracket. Refer to Figures 10A-11 and 10A-12.

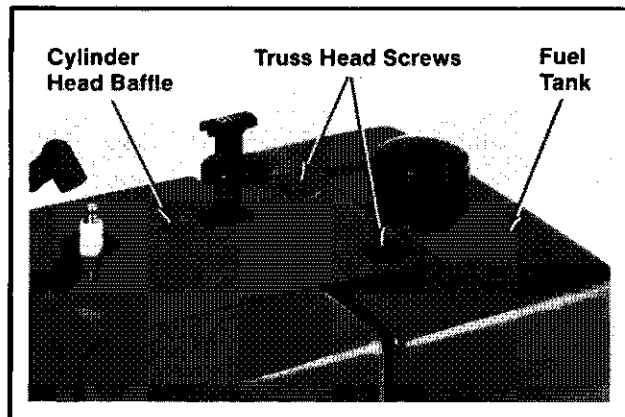

Figure 10A-11. Removing Fuel Tank.

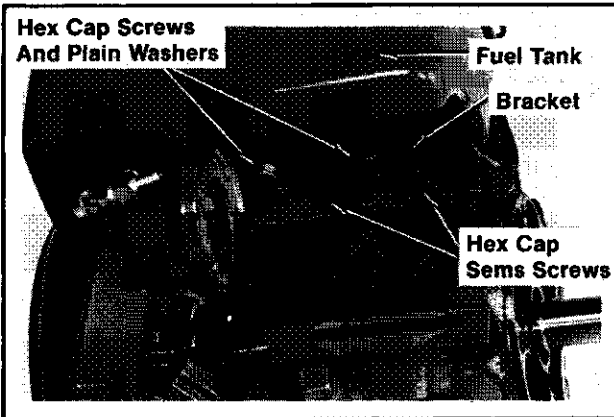

Figure 10A-12. Removing Fuel Tank.

3. Remove the hex cap screws, plain washers, and bracket from fuel tank, if necessary.
4. Remove the hex cap screws, split lock washers, and bracket from crankcase, if necessary. Refer to Figure 10A-13.

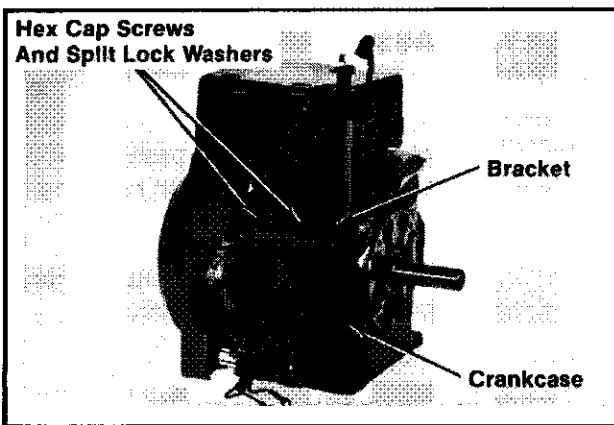

Figure 10A-13. Removing Fuel Tank Bracket From Crankcase.

REMOVE CYLINDER HEAD BAFFLE, BLOWER HOUSING, AND SIDE AIR BAFFLES

1. Remove the hex cap sems screw, spark plug lead clip, plain washer, self-tapping screw, and cylinder head baffle. Refer to Figure 10A-14.

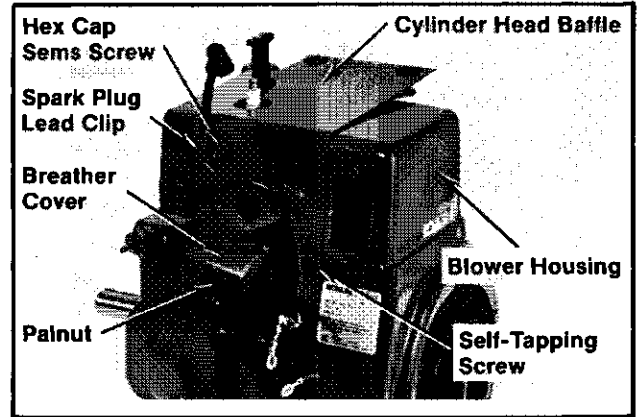

Figure 10A-14. Removing Cylinder Head Baffle, Blower Housing, And Breather Cover.

2. Remove the self-tapping screws, hex cap screw, plain washer, side air baffle, keyswitch panel (if so equipped), and blower housing. Refer to Figure 10A-15.

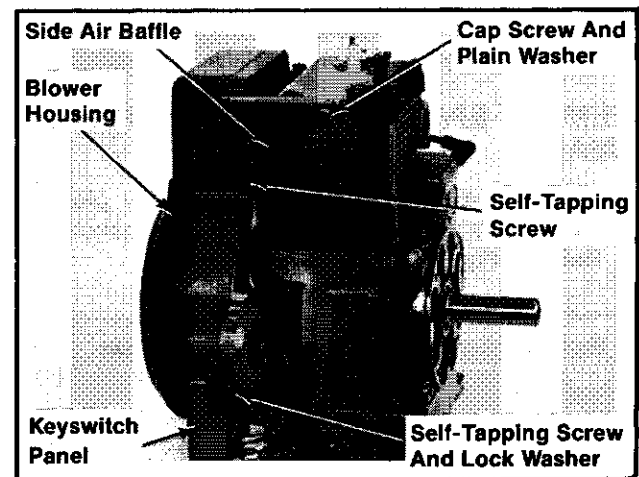

Figure 10A-15. Removing Side Air Baffle, Keyswitch Panel, And Blower Housing.

REMOVE BREATHER ASSEMBLY

1. Remove the palnut and breather cover with filter. Refer to Figure 10A-14.
2. Remove the seal, gasket, breather plate, gasket, and stud (if necessary). Refer to Figure 10A-16.

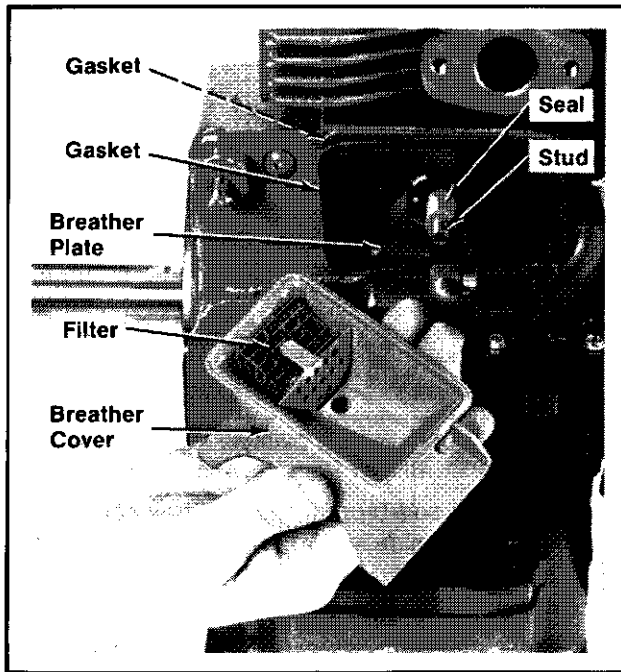

Figure 10A-16. Removing Breather Components.

REMOVE SPARK PLUG AND CYLINDER HEAD

1. Remove the spark plug, hex cap screws, plain washers, bracket, cylinder head, and gasket. Refer to Figure 10A-17.

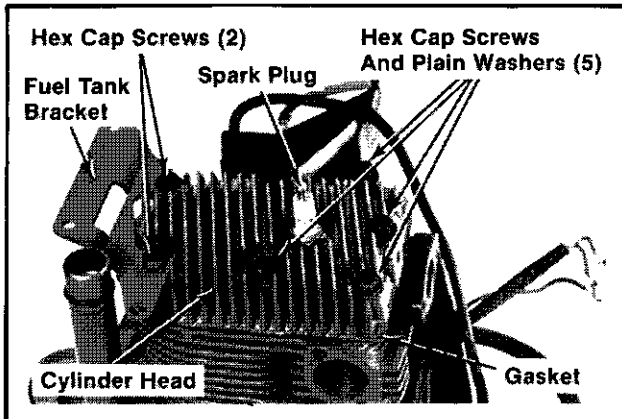

Figure 10A-17. Removing Spark Plug And Cylinder Head.

REMOVE IGNITION MODULE AND AIR Baffle

1. Remove the hex cap sems screws, plain washers, ignition module, and air baffle. Refer to Figure 10A-18.

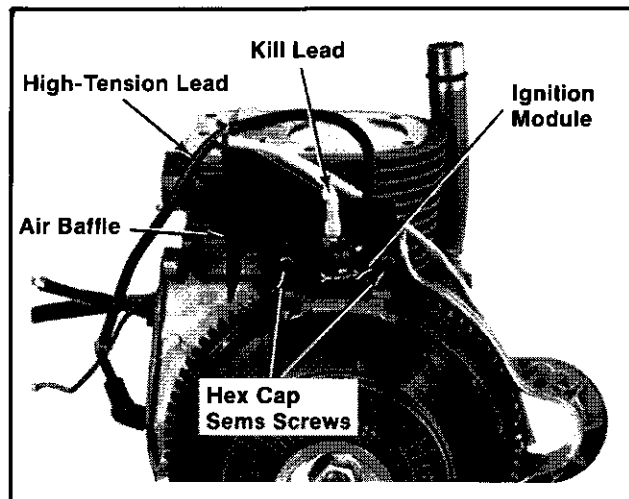

Figure 10A-18. Removing Ignition Module And Air Baffle.

2. Remove the high-tension lead and kill lead from slots in baffle. Separate the ignition module and air baffle, if necessary.

REMOVE DRIVE CUP OR ROPE START PULLEY, GRASS SCREEN, FLYWHEEL, AND FAN

CAUTION: Always use the flywheel strap wrench to hold flywheel when loosening or tightening flywheel and fan retaining fasteners. (Refer to Figure 10A-19 and Section 2, Special Tools.) Do not use any type of bar or wedge between fins of cooling fan, as the fins could become cracked or damaged.

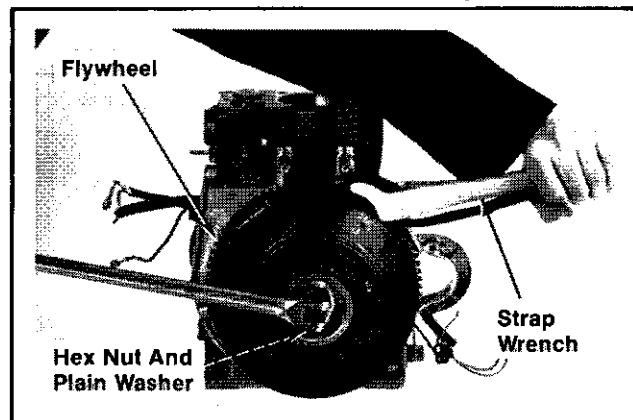

Figure 10A-19. Removing Flywheel Fastener.

Always use a puller to remove flywheel from crankshaft. (Refer to Figure 10A-20 and Section 2, Special Tools.) Do not strike the crankshaft or flywheel, as these parts could become cracked or damaged.

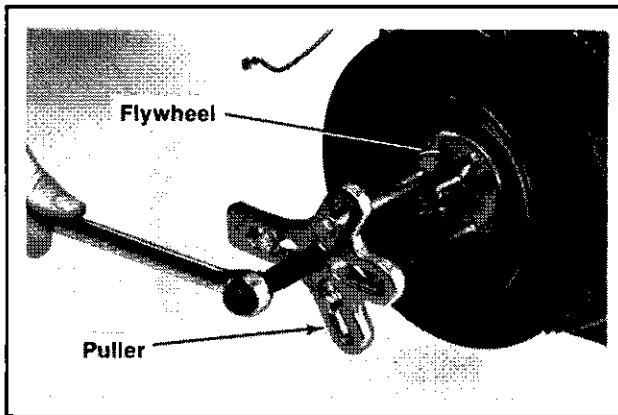

Figure 10A-20. Removing Flywheel Using A Puller.

Rope Start Models

1. Remove the grass screen retainer and grass screen. Refer to Figure 10A-21.

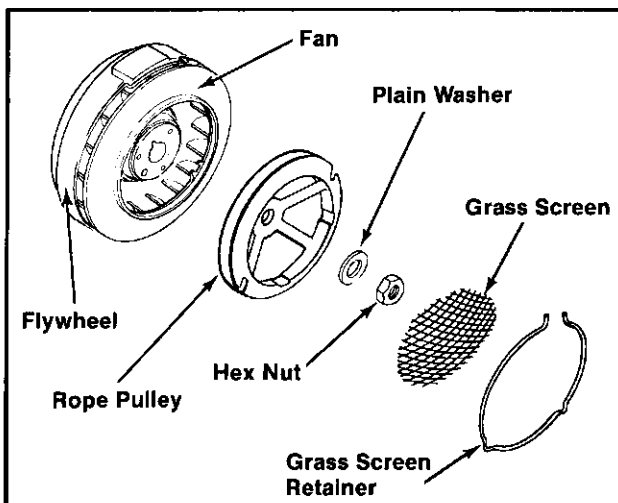

Figure 10A-21. Removing Grass Screen, Rope Pulley, And Flywheel - Rope Start Models.

2. Hold the flywheel with strap wrench and loosen hex nut (Refer to Figure 10A-19). Remove the hex nut, plain washer, and rope pulley.

Retractable Start Models

1. Hold the flywheel with strap wrench and loosen hex nut (Refer to Figure 10A-19). Remove the hex nut, plain washer, and drive cup. Refer to Figure 10A-22.
2. Remove the grass screen from fan.

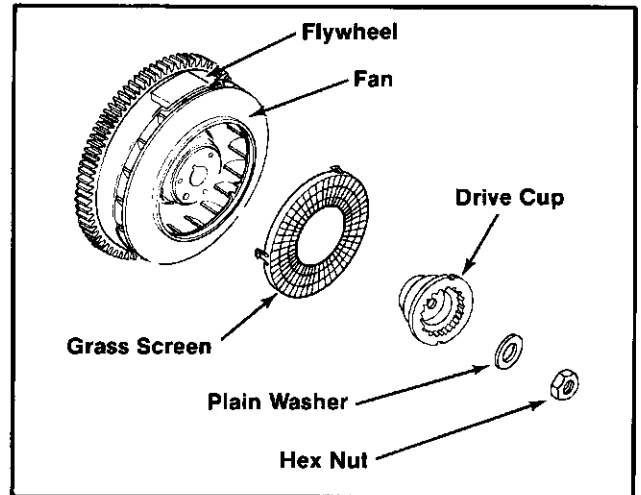

Figure 10A-22. Removing Drive Cup, Grass Screen, And Flywheel - Retractable Start Models.

Electric Start Models

1. Remove the grass screen from fan. Refer to Figure 10A-23.

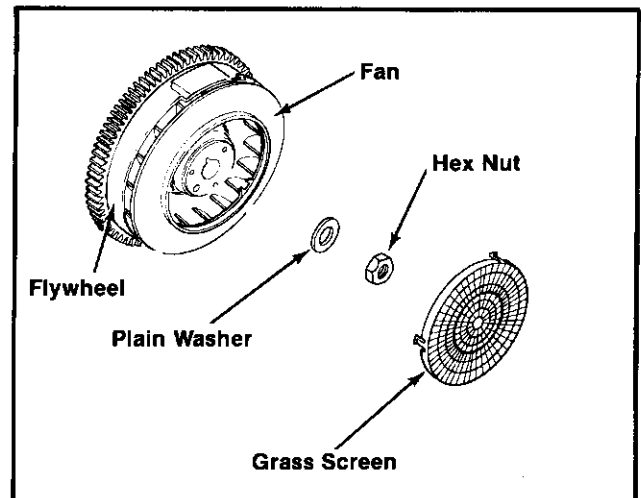

Figure 10A-23. Removing Grass Screen And Flywheel - Electric Start Models.

2. Hold the flywheel with strap wrench and loosen hex nut (refer to Figure 10A-19). Remove the hex and plain washer.

On All Models

3. Remove the flywheel from crankshaft using a puller. Refer to Figure 10A-20.
4. Remove the hex flange screws, spacers and fan. Refer to Figure 10A-24.

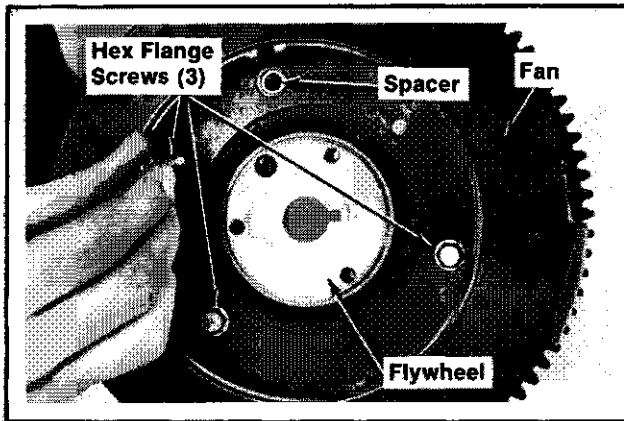

Figure 10A-24. Removing Fan From Flywheel.

WARNING: Ignition Magnet is Not Removable Or Serviceable!



Do not attempt to remove the ignition magnet from flywheel. Loosening or removing the magnet mounting screws could cause the magnet to come off during engine operation and be thrown from the engine causing severe injury. Replace the flywheel if magnet is damaged.

REMOVE STATOR

1. Remove the connector body from stator leads. Refer to Figure 10A-25.

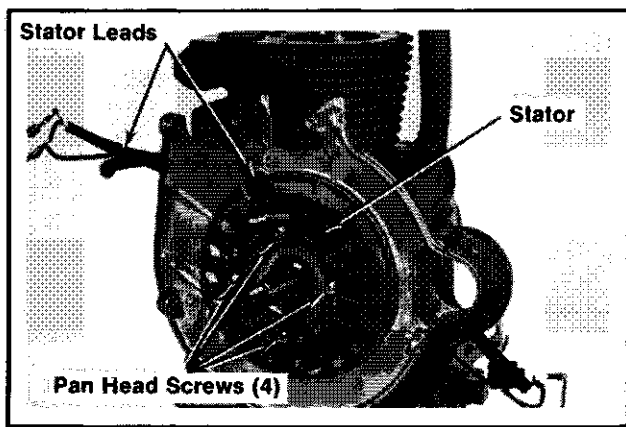

Figure 10A-25. Removing Stator.

2. Remove the pan head screws and stator.

REMOVE VALVES

1. Rotate the crankshaft until piston is at top dead center of compression stroke (both valves closed and piston flush with top of bore).
2. Compress the valve springs with a valve spring compressor and remove keepers. Refer to Figure 10A-26.

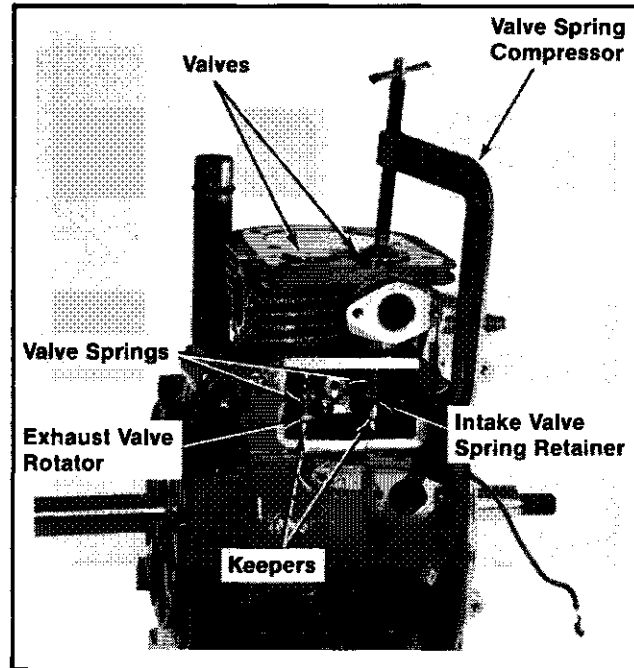

Figure 10A-26. Removing Valves.

3. Remove the valve spring compressor, then remove the valves, intake valve spring retainer, exhaust valve rotator, and valve springs.

NOTE: Some models use a valve rotator on both valves.

REMOVE OIL PAN

CAUTION: Make sure the piston is at top dead center in bore to prevent damage to oil dipper on connecting rod.

1. Remove the hex cap sems screws and solenoid bracket from starter side of oil pan. Refer to Figure 10A-27.

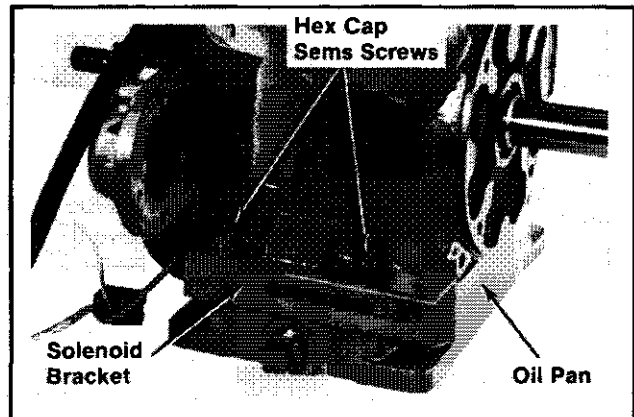

Figure 10A-27. Removing Solenoid Bracket And Oil Pan.

- Remove the hex nuts, split lock washers, plain washers, and handle bracket from studs on carburetor side of oil pan. Remove the oil pan and gasket from crankcase. Refer to Figure 10A-28.

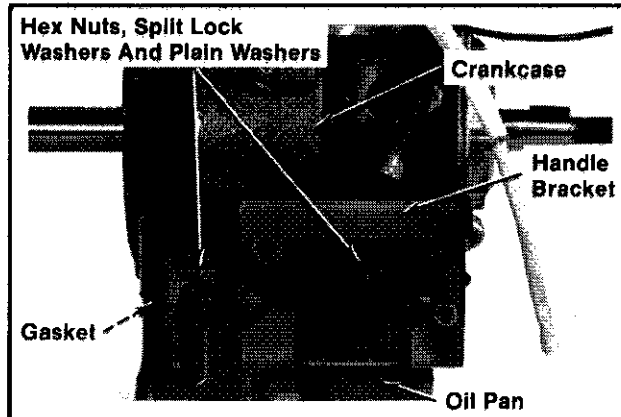

Figure 10A-28. Removing Handle Bracket And Oil Pan.

REMOVE CONNECTING ROD AND PISTON

- Remove the hex nuts and connecting rod cap. Refer to Figure 10A-29.

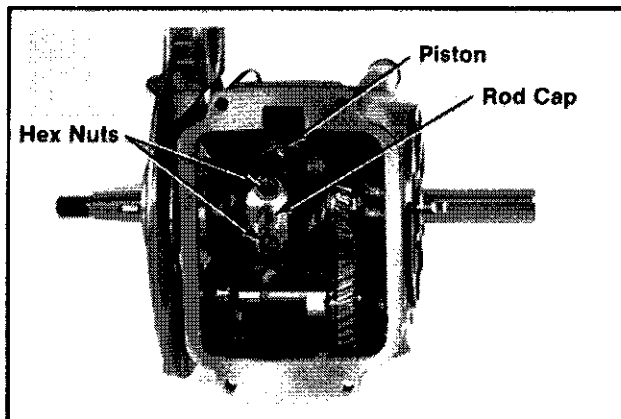

Figure 10A-29. Removing Connecting Rod And Piston.

NOTE: If a carbon ridge is present at top of bore, use a ridge reamer tool to remove it before attempting to remove piston.

- Carefully push the connecting rod and piston out top of bore.

REMOVE PISTON FROM CONNECTING ROD

- Remove the retainer and wrist pin. Separate the piston from connecting rod. Refer to Figure 10A-30.

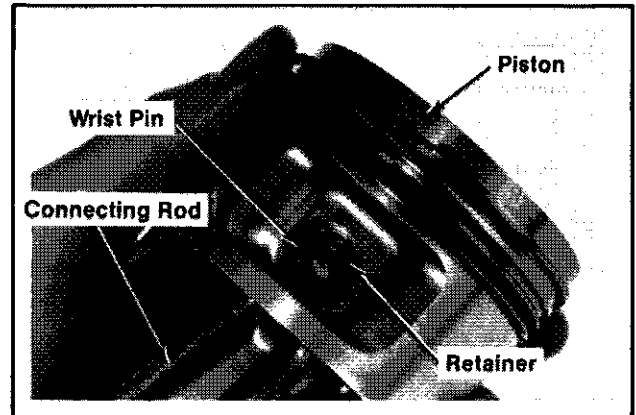

Figure 10A-30. Removing Piston From Connecting Rod.

REMOVE PISTON RINGS

- Remove the top and center compression rings using a ring expander tool. Refer to Figure 10A-31.

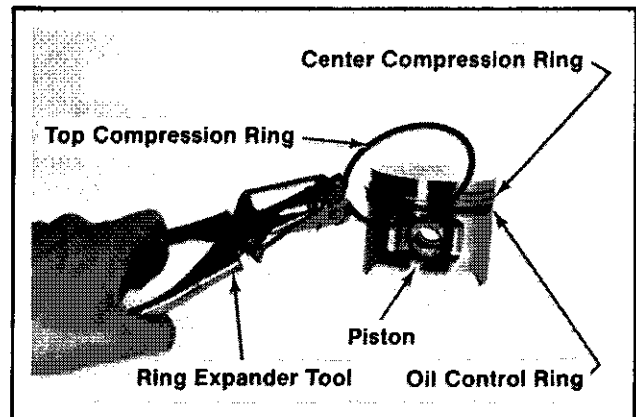

Figure 10A-31. Removing Piston Rings.

- Remove oil control ring rails, then remove rails spacer.

REMOVE CRANKSHAFT AND BEARING PLATE

NOTE: To make reassembly easier, mark the positions of the fuel line and wiring harness before removing the bearing plate. Mark the locations where they exit from between the crankcase and bearing plate, on both the carburetor and starter sides.

- Remove the hex cap screws securing bearing plate to crankcase.
- Remove the bearing plate from crankshaft using a puller. Refer to Figure 10A-32.

NOTE: The front bearing may remain either in the bearing plate or on the crankshaft, when the bearing plate is removed.

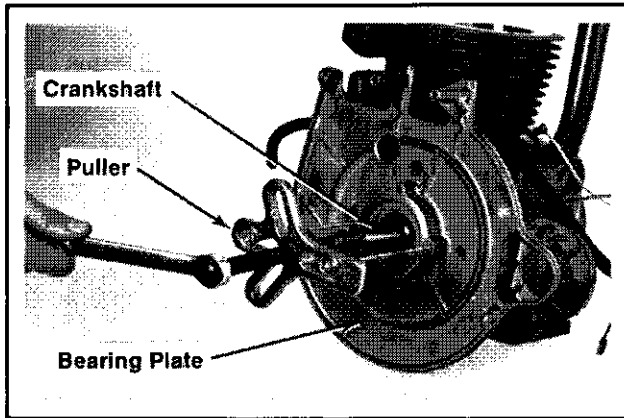

Figure 10A-32. Removing Bearing Plate Using A Puller.

3. Press the crankshaft out of crankcase from PTO side.

NOTE: If the repair does not require separating the bearing plate from crankshaft, the crankshaft and bearing plate can be pressed out as an assembly.

REMOVE CAMSHAFT AND TAPPETS

1. Drive the camshaft pin (and cup plug on bearing plate side) out of crankcase from PTO side.
2. Remove the camshaft pin, camshaft, and shims (on bearing plate side of camshaft). Refer to Figure 10A-33.

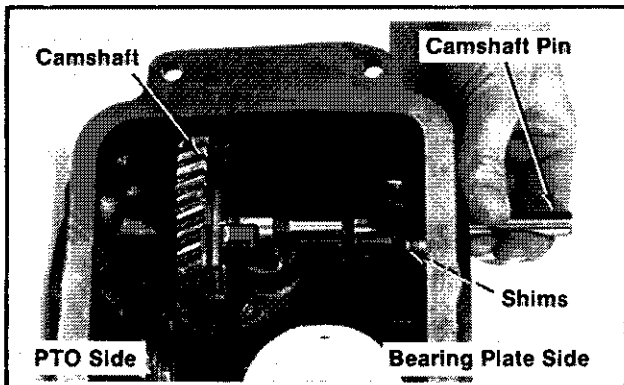

Figure 10A-33. Removing Camshaft.

3. Mark the tappets as being intake or exhaust. Remove the tappets from crankcase. Refer to Figure 10A-34.

NOTE: The intake valve tappet is closest to the bearing plate side of crankcase. The exhaust valve tappet is closest to the PTO side of crankcase.

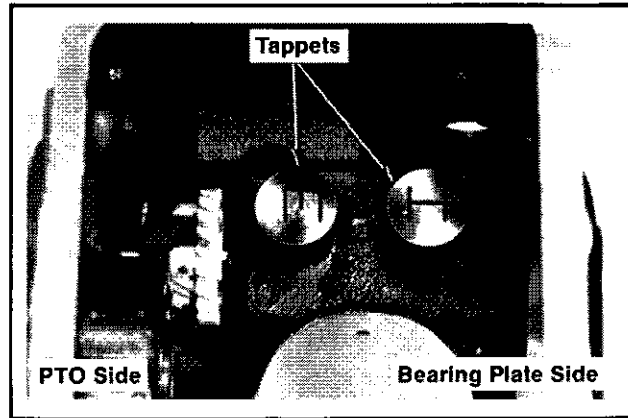

Figure 10A-34. Removing Tappets.

REMOVE GOVERNOR GEAR AND CROSS SHAFT

1. Remove the stop pin, copper washer, and governor gear. Refer to Figures 10A-35 and 10A-36.

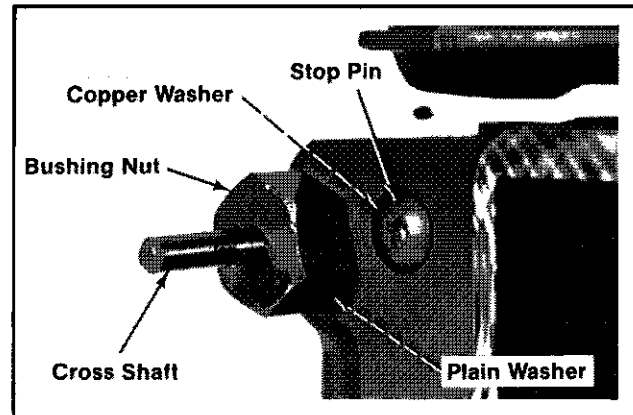

Figure 10A-35. Removing Cross Shaft And Stop Pin.

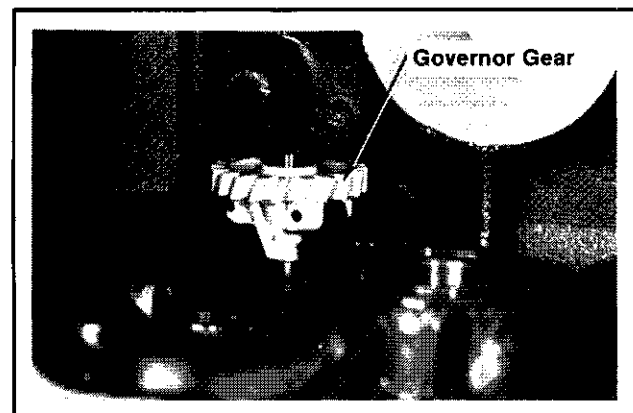

Figure 10A-36. Removing Governor Gear.

-
2. Remove the bushing nut and plain washer.
Remove the cross shaft from inside crankcase.

REMOVE OIL SEALS

1. Remove the oil seals from crankcase and bearing plate.

REMOVE BEARINGS

1. Press the bearings out of bearing plate and crankcase.

NOTE: If bearings have remained on the crankshaft, remove using a puller.

SECTION 10B

MAGNUM

Single Cylinder Engine
Service Manual

Models M8, M10, M12
M14, M16

TP-2203-A 3/86

KOHLER
engines

MODELS M10, M12, M14, M16 DISASSEMBLY

WARNING: Accidental Starts!



Before servicing the engine or equipment, always remove the spark plug lead to prevent the engine from starting accidentally. Ground the lead to prevent sparks that could cause fires.

The following sequence is suggested for complete engine disassembly. This procedure may have to be varied slightly to accommodate options or special equipment.

Clean all parts thoroughly as the engine is disassembled. Only clean parts can be accurately inspected and gauged for wear or damage. There are many commercially available cleaners that quickly remove grease, oil, and grime from engine parts. When such a cleaner is used, follow the manufacturer's instructions carefully. Make sure all traces of the cleaner are removed before the engine is reassembled and placed in operation—even small amounts of these cleaners quickly break down the lubricating properties of engine oil.

1. Disconnect spark plug lead.
2. Drain oil from crankcase.
3. Remove air cleaner.
4. Remove muffler.
5. Remove rectifier/regulator.
6. Remove choke linkage, throttle linkage, and carburetor.
7. Remove external governor components, and throttle and choke controls.
8. Remove breather.
9. Remove fuel pump.
10. Remove retractable starter.
11. Remove fuel tank and solenoid.
12. Remove oil fill/dipstick tube.

13. Remove electric starter.
14. Remove cylinder head baffle, blower housing, and side air baffles.
15. Remove spark plug and cylinder head.
16. Remove ignition module and air baffle.
17. Remove drive cup or rope start pulley, grass screen, flywheel and fan.
18. Remove stator.
19. Remove valves.
20. Remove oil pan.
21. Remove connecting rod and piston.
22. Remove piston from connecting rod.
23. Remove piston rings.
24. Remove crankshaft and bearing plate.
25. Remove camshaft and tappets.
26. Remove balance gears.
27. Remove governor gear and cross shaft.
28. Remove oil seals.
29. Remove bearings.

DISCONNECT SPARK PLUG LEAD DRAIN OIL FROM CRANKCASE REMOVE AIR CLEANER

1. Remove the wing nut and air cleaner cover. Refer to Figure 10B-1.

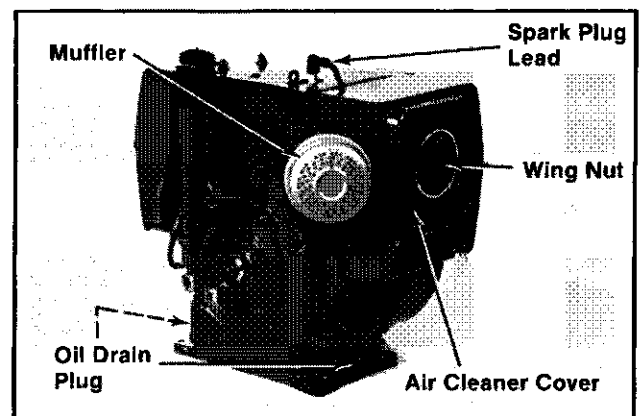

Figure 10B-1. Removing Spark Plug Lead, Oil Drain Plug, Air Cleaner Cover, And Muffler.

10

2. Remove the precleaner, element cover nut, element cover, paper element, and seal. Refer to Figures 10B-2 and 10B-3.

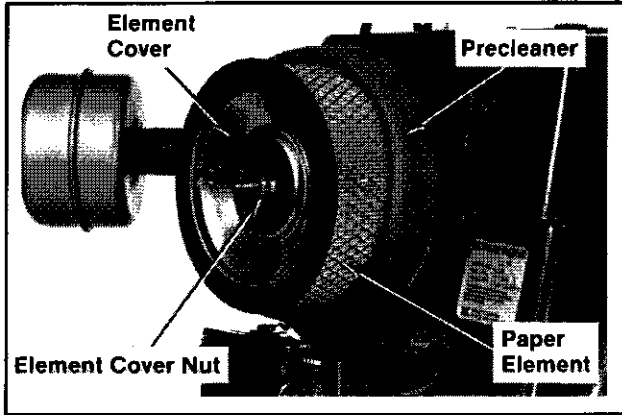

Figure 10B-2. Removing Air Cleaner Element.

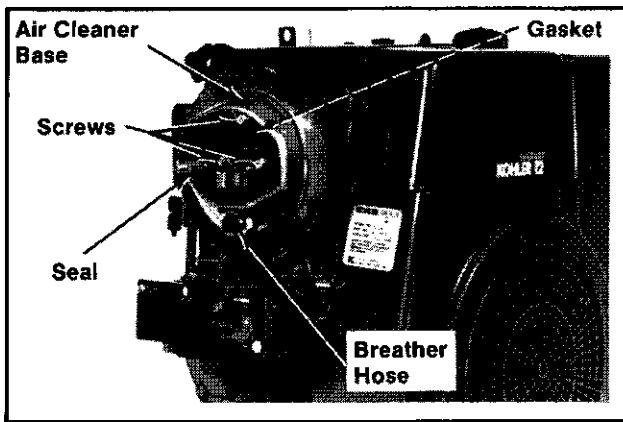

Figure 10B-3. Removing Air Cleaner Base.

3. Remove the three screws, air cleaner base, gasket, and breather hose. Refer to Figure 10B-3.

REMOVE MUFFLER

1. Remove the muffler and threaded exhaust pipe. Refer to Figure 10B-1.

REMOVE RECTIFIER-REGULATOR

1. Remove two screws and the rectifier-regulator. Refer to Figure 10B-4.
2. Remove the electrical connector from the rectifier-regulator.

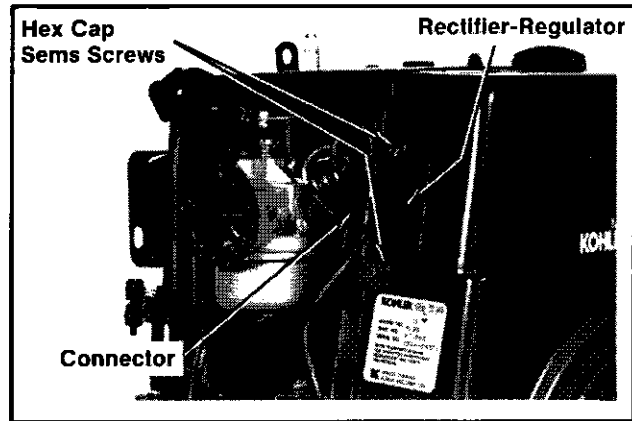

Figure 10B-4. Removing Rectifier-Regulator.

REMOVE CHOKE LINKAGE, THROTTLE LINKAGE, AND CARBURETOR

WARNING: Explosive Fuel!



Gasoline may be present in carburetor and fuel system. Gasoline is extremely flammable, and its vapors can explode if ignited. Keep cigarettes, sparks, open flames, and other sources of ignition away from the engine. Wipe up spilled fuel immediately.

1. Remove the throttle linkage from the nylon inserts in governor arm and carburetor throttle lever. Remove the choke linkage from the nylon insert in the choke control lever, then from the carburetor choke lever. Refer to Figure 10B-5.
2. Close the fuel shut-off valve at fuel tank (if so equipped) or drain fuel from tank.

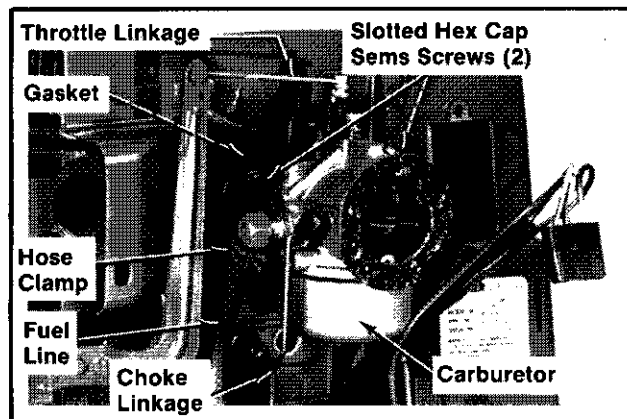

Figure 10B-5. Removing Choke Linkage, Throttle Linkage, And Carburetor.

3. Loosen the hose clamp and remove fuel line from the carburetor inlet.
4. Remove two slotted hex cap sems screws, the carburetor, and gasket.

REMOVE EXTERNAL GOVERNOR COMPONENTS, AND THROTTLE AND CHOKE CONTROLS

1. Note the position of the governor spring in governor arm. Refer to Figure 10B-6.

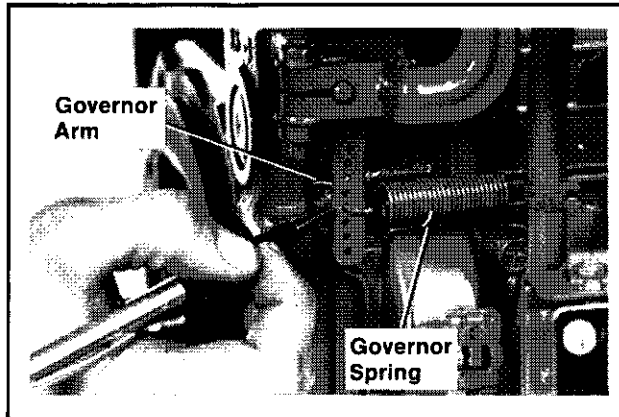

Figure 10B-6. Governor Spring Location In Governor Arm.

2. Loosen palnut and remove governor arm from cross shaft. Refer to Figure 10B-7.

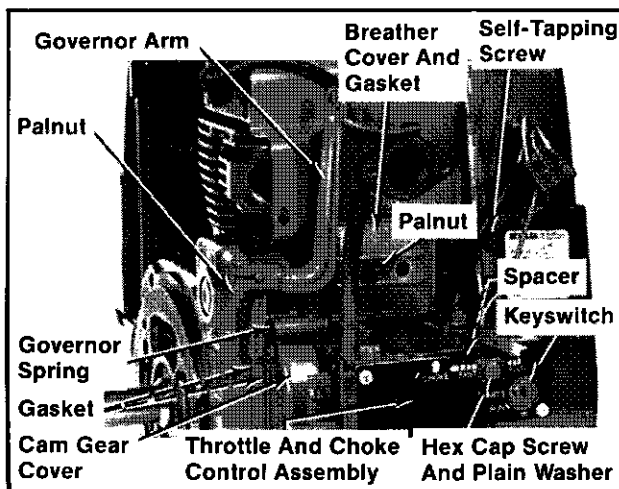

Figure 10B-7. Removing External Governor Components, And Throttle And Choke Controls.

NOTE: Loosening palnut or removing governor arm will disrupt governor arm to cross shaft adjustment. Readjustment will be required upon reassembly.

3. Remove the governor spring from the governor arm.
4. Remove the electrical connector from the back of keyswitch.

5. Remove the hex cap screw, plain washer, and spacer. Remove the self-tapping screw securing the bracket to blower housing/bearing plate. Remove four hex cap screws, cam gear cover, gasket, throttle and choke control assembly, and gasket.

REMOVE BREATHER

1. Remove palnut, breather cover, and gasket. Refer to Figure 10B-7.
2. Remove the filter, seal, reed stop, reed, breather plate, gasket, and stud. Refer to Figure 10B-8.

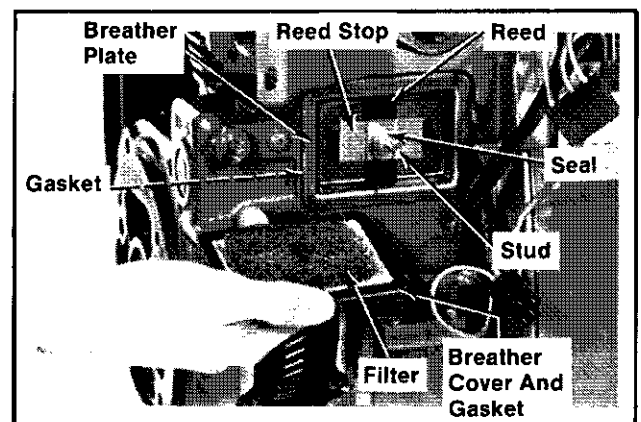

Figure 10B-8. Removing Breather Components.

REMOVE FUEL PUMP

1. Disconnect the fuel line from the fuel pump inlet fitting. Refer to Figure 10B-9.

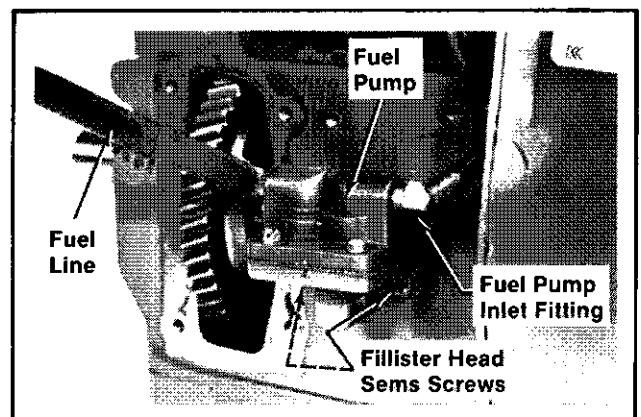

Figure 10B-9. Removing Fuel Pump.

2. Remove the fillister head sems screws, plain washers, fuel pump, and gasket.

REMOVE RETRACTABLE STARTER

1. Remove five screws and the starter assembly.

REMOVE FUEL TANK AND SOLENOID

WARNING: Explosive Fuel!



Gasoline may be present in fuel tank and fuel system. Gasoline is extremely flammable, and its vapors can explode if ignited. Keep cigarettes, sparks, open flames, and other sources of ignition away from engine. Wipe up spilled fuel immediately.

1. Disconnect leads from starter and solenoid. Refer to Figure 10B-10.

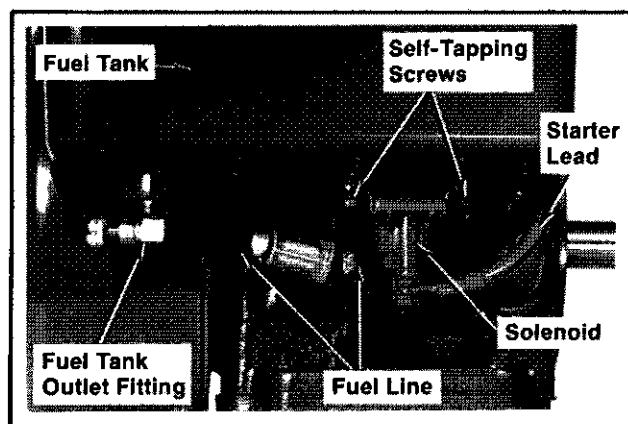

Figure 10B-10. Removing Fuel Tank.

2. Remove the self-tapping screws and solenoid from the fuel tank lower bracket.
3. Remove the fuel line from tank outlet fitting.
4. Remove the self-tapping screw securing starter tail brace to fuel tank bracket and remove the two acorn nuts and washers at the top of fuel tank. Refer to Figure 10B-11.

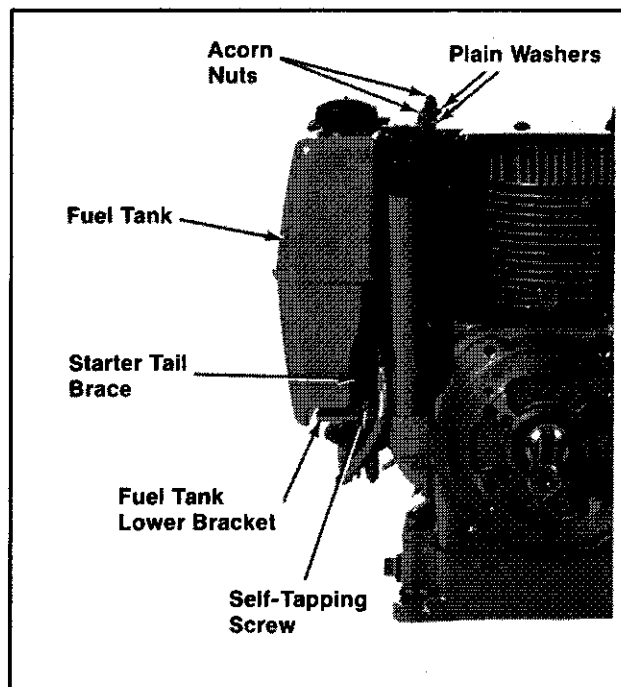

Figure 10B-11. Removing Fuel Tank.

5. Remove two hex cap sems screws and fuel tank with bracket. Refer to Figure 10B-12.

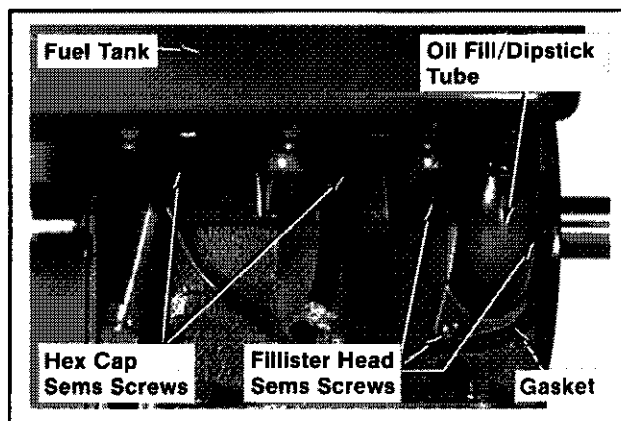

Figure 10B-12. Removing Fuel Tank And Oil Fill/Dipstick Tube.

6. Remove palnuts, fuel tank lower bracket, and isolation mounts from fuel tank, if necessary.

REMOVE OIL FILL/DIPSTICK TUBE

1. Remove the dipstick, fillister head sems screws, oil fill/dipstick tube, and gasket. Refer to Figure 10B-12.

REMOVE ELECTRIC STARTER

1. Place tape across the commutator end cap and starter frame. Refer to Figure 10B-13.

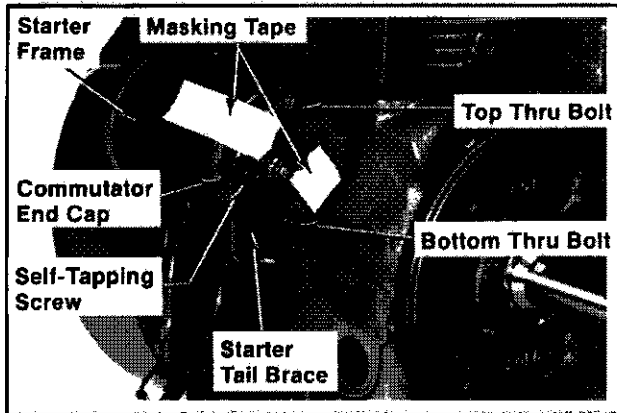

Figure 10B-13. Removing Starter Tail Brace And Starter.

2. Remove the self-tapping screw, bottom through bolt, and starter tail brace.
3. Hold the commutator end cap against frame and carefully remove top thru bolt. Remove starter from bearing plate. Refer to Figure 10B-14.



Figure 10B-14. Removing Starter.

CAUTION: The starter may become disassembled if end caps are not taped or held against frame.

4. Reinstall thru bolts and two (2) 1/4-20 hex nuts to keep starter assembled during remaining engine disassembly.

REMOVE CYLINDER HEAD BAFFLE, BLOWER HOUSING, AND SIDE AIR BAFFLES

1. Remove the hex cap sems screw, plain washer, spark plug lead clip, and carburetor side air baffle. Refer to Figure 10B-15.

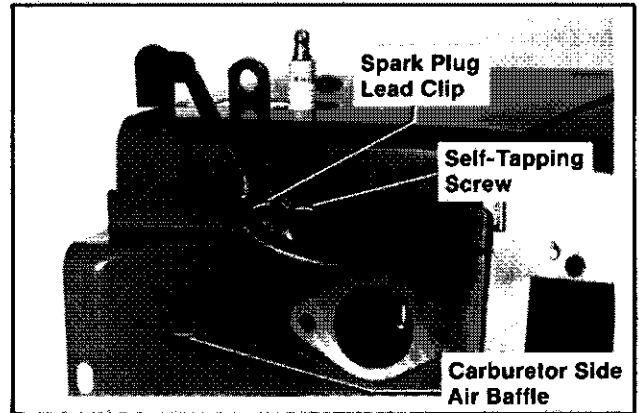

Figure 10B-15. Removing Carburetor Side Air Baffle.

2. Remove the hex cap sems screw, plain washer, self-tapping screw, and starter side air baffle. Refer to Figure 10B-16.

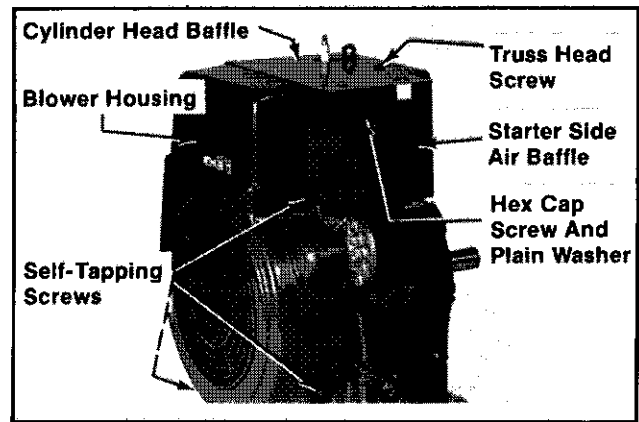

Figure 10B-16. Removing Starter Side Air Baffle, Cylinder Head Baffle And Blower Housing.

3. Remove the truss head screw and cylinder head baffle.
4. Remove the remaining self-tapping screws and the blower housing.

REMOVE SPARK PLUG AND CYLINDER HEAD

1. Remove the spark plug, hex cap screws, lifting strap, hex spacer screw, plain washers, cylinder head, and gasket. Refer to Figure 10B-17.

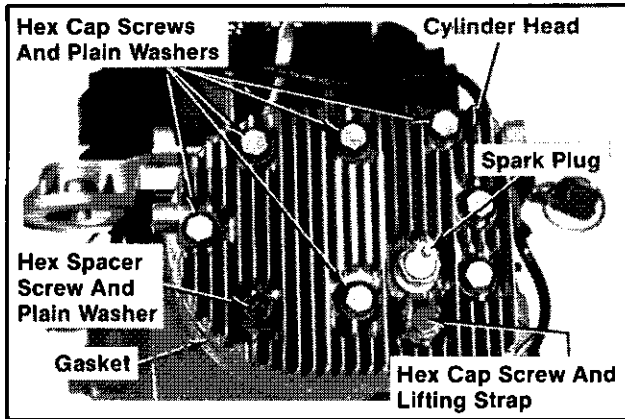

Figure 10B-17. Removing Spark Plug And Cylinder Head.

REMOVE IGNITION MODULE AND AIR BAFFLE

1. Remove the hex cap sems screws, plain washers, ignition module, and air baffle. Refer to Figure 10B-18.

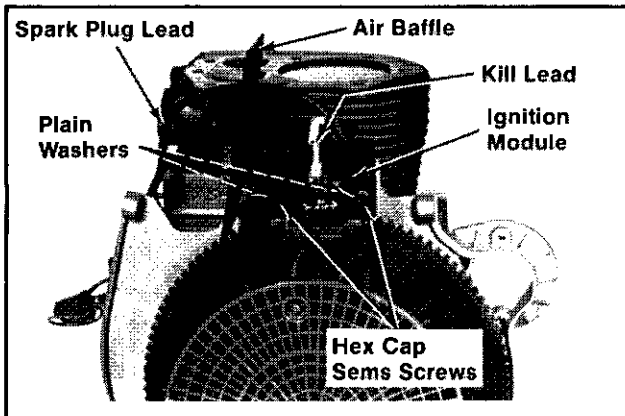

Figure 10B-18. Removing Ignition Module And Air Baffle.

2. Remove the spark plug lead and kill lead from the slots in the baffle. Separate the ignition module and air baffle, if necessary.

REMOVE DRIVE CUP OR ROPE START PULLEY, GRASS SCREEN, FLYWHEEL, AND FAN

CAUTION: Always use a flywheel strap wrench to hold the flywheel when loosening or tightening flywheel and fan retaining fasteners. (Refer to Figure 10B-19.) Do not use any type of bar or wedge between fins of cooling fan, as the fins could become cracked or damaged.

Always use a puller to remove flywheel from crankshaft. Do not strike the crankshaft or flywheel, as these parts could become cracked or damaged.

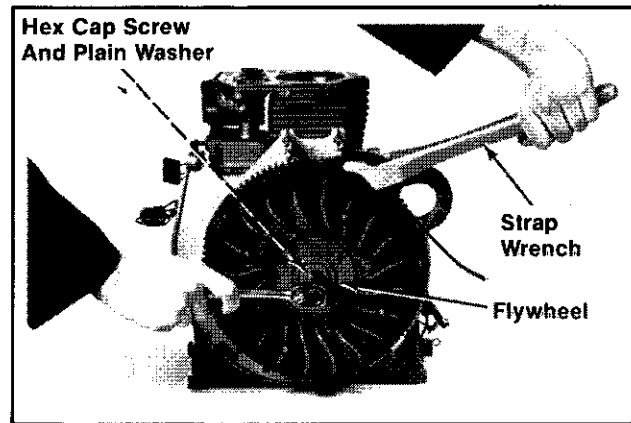

Figure 10B-19. Removing Flywheel Fastener.

Rope Start Models

1. Remove the grass screen retainer and wire mesh grass screen from rope pulley. Refer to Figure 10B-20.

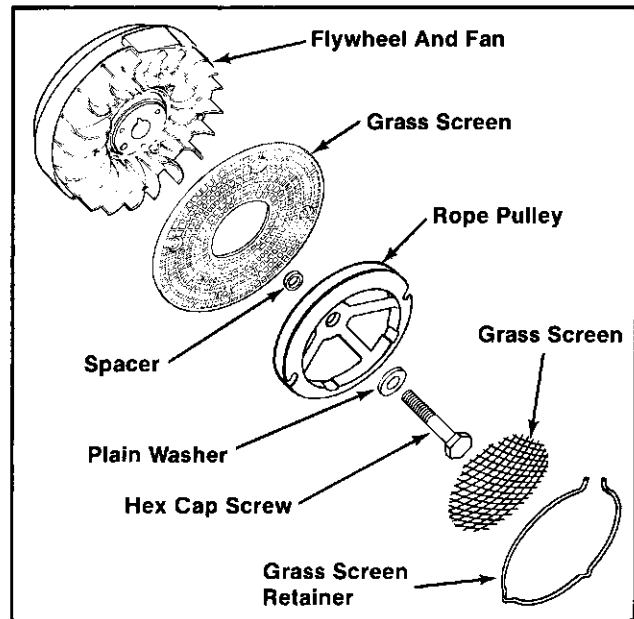

Figure 10B-20. Removing Grass Screen, Rope Pulley, and Flywheel — Rope Start Models.

2. Hold the flywheel with a strap wrench and loosen the hex cap screw (Refer to Figure 10B-19). Remove the hex cap screw, plain washer, rope pulley, and spacer. Remove the nylon grass screen from the fan. Refer to Figure 10B-20.

Retractable Start Models

1. Hold the flywheel with a strap wrench and loosen hex cap screw securing flywheel to crankshaft (Refer to Figure 10B-19). Remove the hex cap screw, plain washer, and drive cup. Refer to Figure 10B-21.

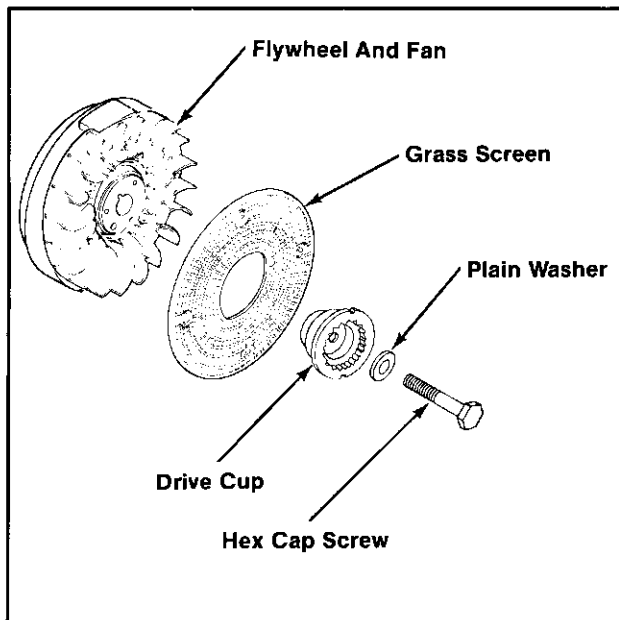

Figure 10B-21. Removing Grass Screen, Drive Cup, And Flywheel — Retractable Start Models.

2. Remove the grass screen from the fan.

Electric Start Models

1. Remove the grass screen from the fan. Refer to Figure 10B-22.

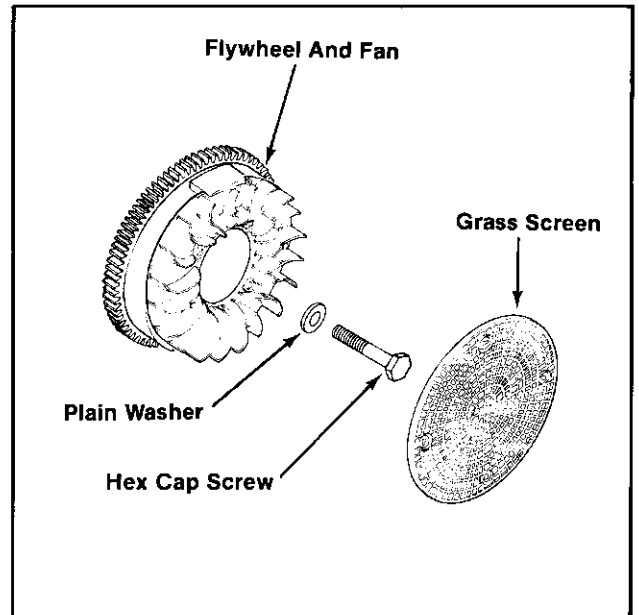

Figure 10B-22. Removing Grass Screen And Flywheel — Electric Start Models.

2. Hold the flywheel with a strap wrench and loosen hex cap screw securing flywheel to crankshaft (Refer to Figure 10B-19). Remove the hex cap screw and plain washer.

On All Models

3. Remove the flywheel from the crankshaft using a puller.
4. Remove the hex cap screws, fan, and spacers, if necessary. Refer to Figure 10B-23.

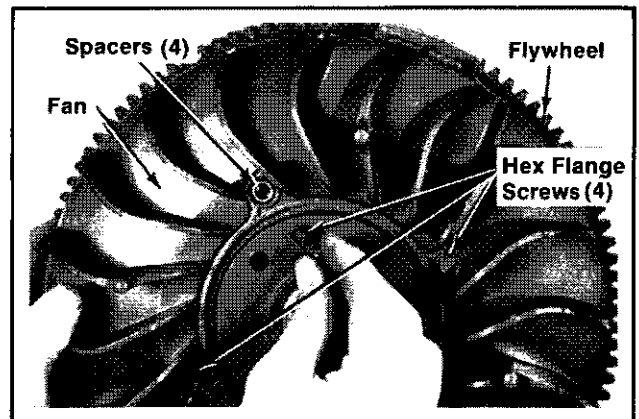

Figure 10B-23. Removing Fan From Flywheel.

WARNING: Ignition magnet is not removable or serviceable!



Do not attempt to remove ignition magnet from flywheel. Loosening or removing magnet mounting screws could cause the magnet to come off during engine operation and be thrown from the engine causing severe injury. Replace the flywheel if magnet is damaged.

REMOVE STATOR

1. Remove the connector body from the stator leads. Remove the self-tapping screw and stator lead clip from bearing plate. Refer to Figure 10B-24.

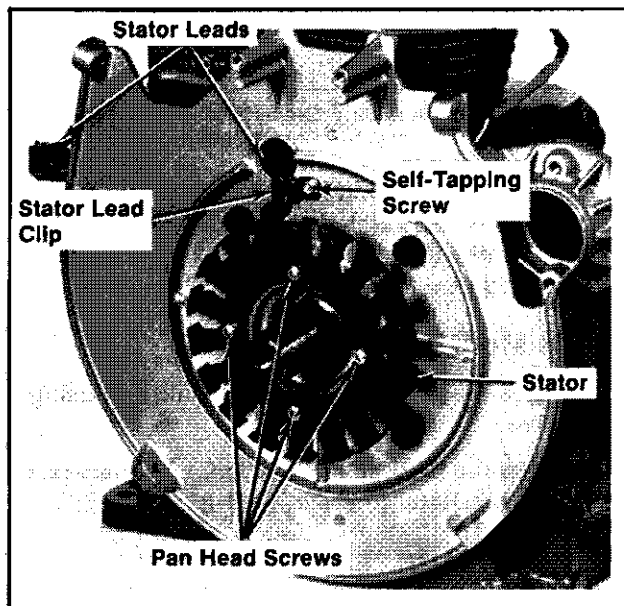

Figure 10B-24. Removing Stator.

2. Remove the pan head screws and stator.

REMOVE VALVES

1. Rotate the crankshaft until the piston is at top dead center of compression stroke (both valves closed and piston flush with top of bore).
2. Compress the valve springs with a valve spring compressor and remove the keepers. Refer to Figure 10B-25.

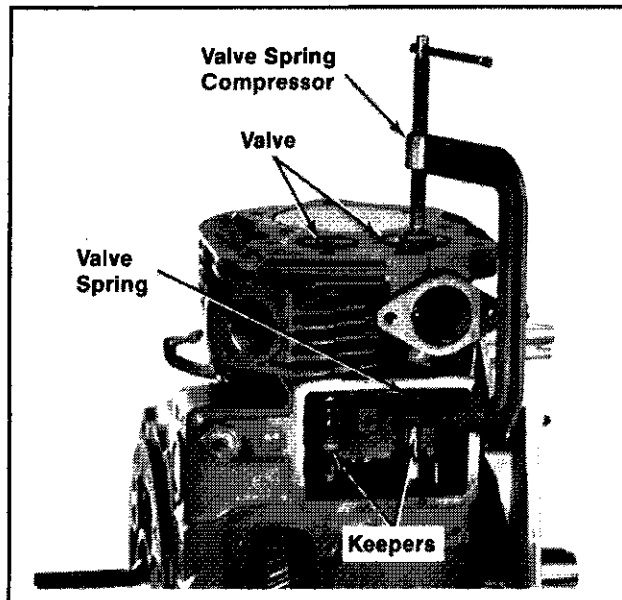

Figure 10B-25 Removing Valves.

3. Remove the valve spring compressor, then remove the valves, intake valve spring lower retainer, exhaust valve rotator, valve springs, and valve spring upper retainers. Refer to Figure 10B-26.

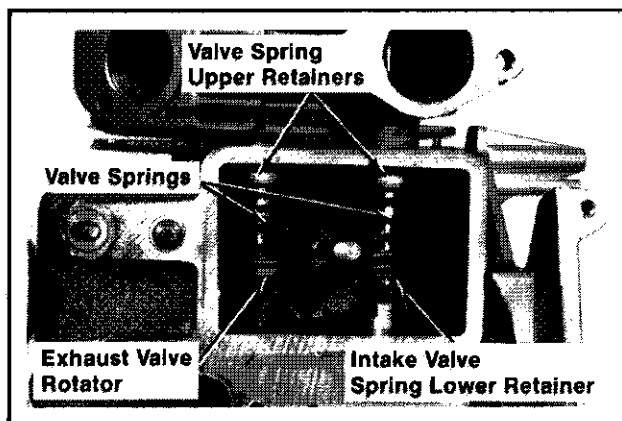

Figure 10B-26. Removing Valves.

NOTE: Some models use a valve rotator on both valves.

REMOVE OIL PAN

CAUTION: Make sure the piston is at top dead center in bore to prevent damage to oil dipper on connecting rod.

1. Remove the hex cap screws, oil pan, and gasket. Refer to Figure 10B-27.

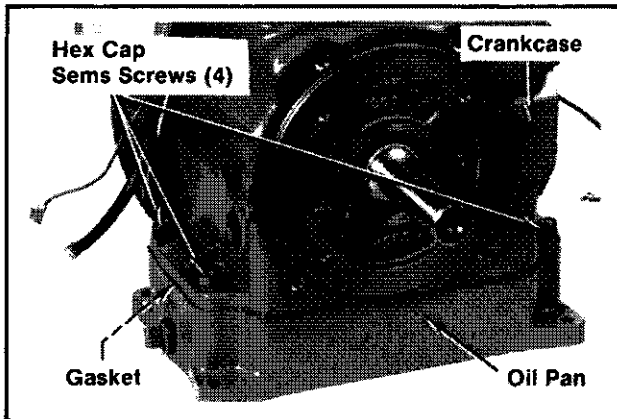

Figure 10B-27. Removing Oil Pan.

REMOVE CONNECTING ROD AND PISTON

1. Remove the hex nuts and connecting rod cap. Refer to Figure 10B-28.

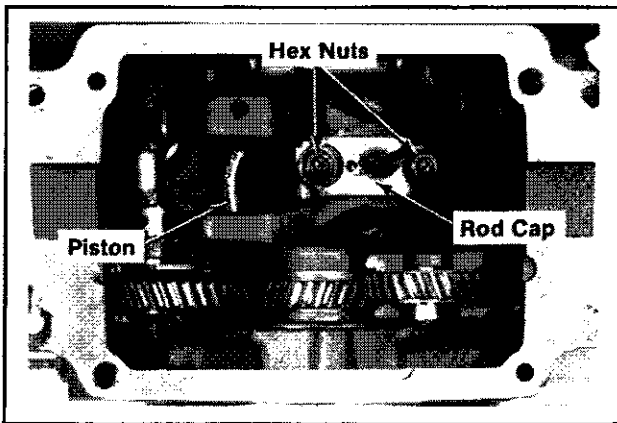

Figure 10B-28. Removing Connecting Rod And Piston.

NOTE: If a carbon ridge is present at top of bore, use a ridge reamer tool to remove it before attempting to remove piston.

2. Carefully push the connecting rod and piston out top of bore.

REMOVE PISTON FROM CONNECTING ROD

1. Remove the retainer and wrist pin. Separate the piston from the connecting rod. Refer to Figure 10B-29.

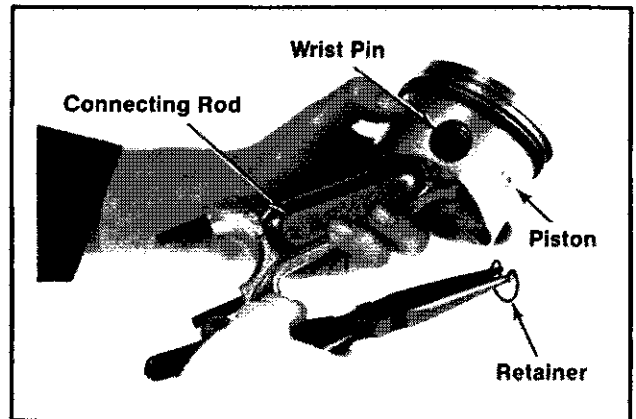

Figure 10B-29. Removing Piston From Connecting Rod.

REMOVE PISTON RINGS

1. Remove the top and center compression rings and the oil control ring spacer using a ring expander tool. Refer to Figure 10B-30.

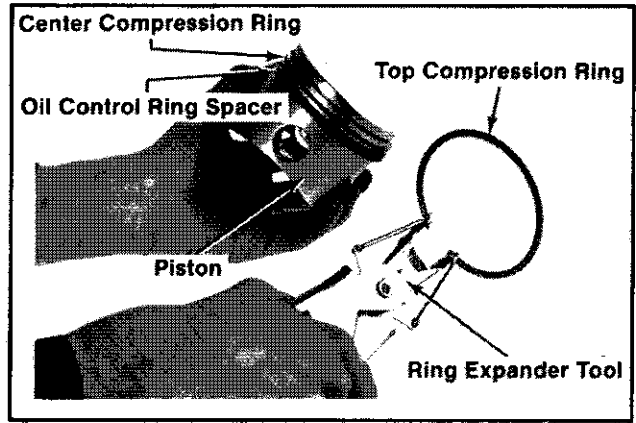

Figure 10B-30. Removing Piston Rings.

2. Remove the rails and expander spring(s).

REMOVE CRANKSHAFT AND BEARING PLATE

NOTE: To make reassembly easier, mark the positions of the fuel line and wiring harness before removing the bearing plate. Mark the locations where they exit from between the crankcase and bearing plate, on both the carburetor and starter sides.

1. Remove the hex cap sems screws securing the bearing plate to crankcase. Refer to Figure 10B-31.

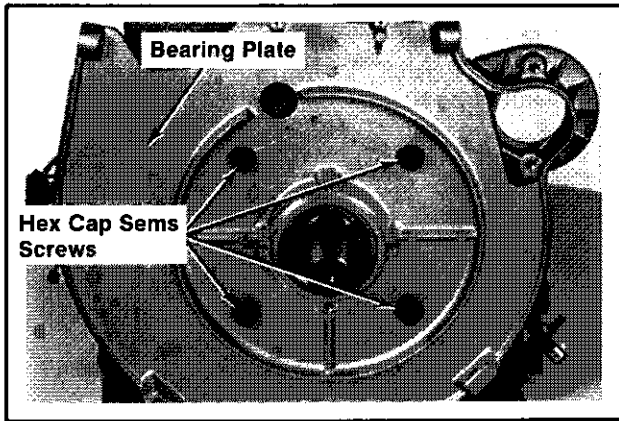

Figure 10B-31. Removing Bearing Plate Mounting Screws.

- Remove the bearing plate from the crankshaft using a puller. Refer to Figure 10B-32.

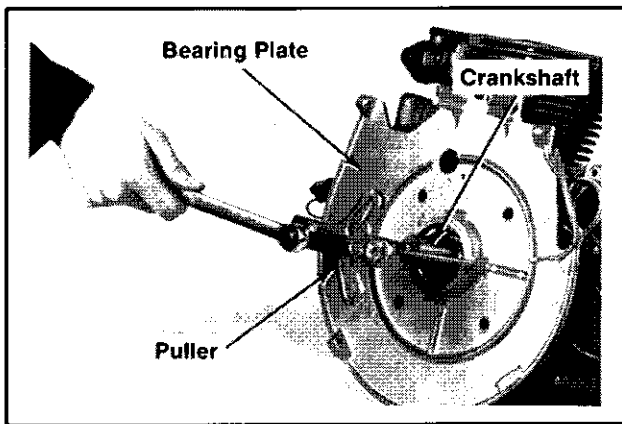

Figure 10B-32. Removing Bearing Plate Using A Puller.

NOTE: The front bearing may remain either in the bearing plate or on the crankshaft when the bearing plate is removed.

- Press the crankshaft out of the crankcase from the PTO side.

NOTE: If the repair does not require separating the bearing plate from crankshaft, the crankshaft and bearing plate can be pressed out as an assembly.

REMOVE CAMSHAFT AND TAPPETS

- Drive the camshaft pin (and cup plug on bearing plate side) out of the crankcase from the PTO side.
- Remove the camshaft pin, camshaft, and shim(s) (on bearing plate side of camshaft). Refer to Figure 10B-33.

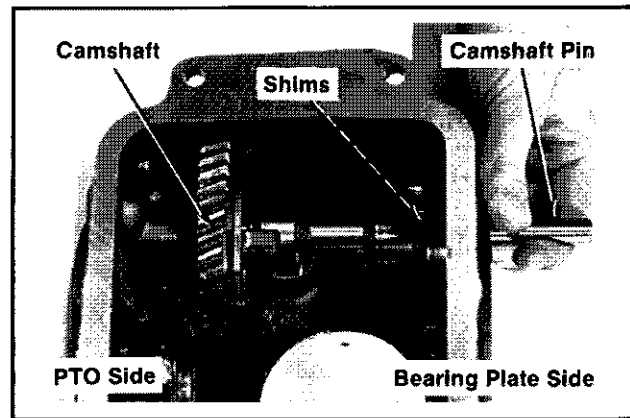

Figure 10B-33. Removing Camshaft.

- Mark the tappets as being either intake or exhaust. Refer to Figure 10B-34. Remove the tappets from the crankcase.

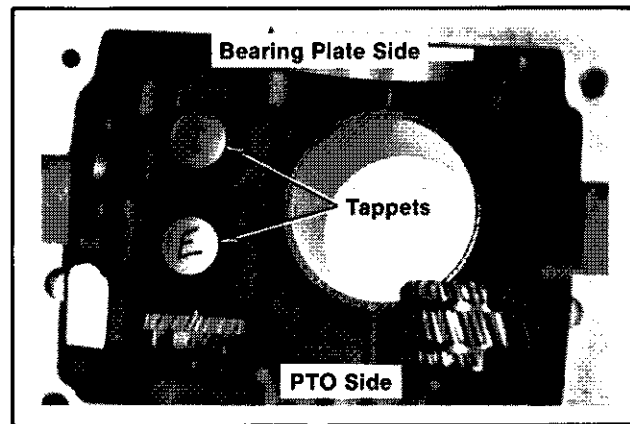

Figure 10B-34. Removing Tappets.

NOTE: The intake valve tappet is closest to the bearing plate side of crankcase. The exhaust valve tappet is closest to the PTO side of crankcase.

REMOVE BALANCE GEARS

- Remove the retaining rings, shims, balance gears with needle bearings, shims, and spacers. Refer to Figure 10B-35.

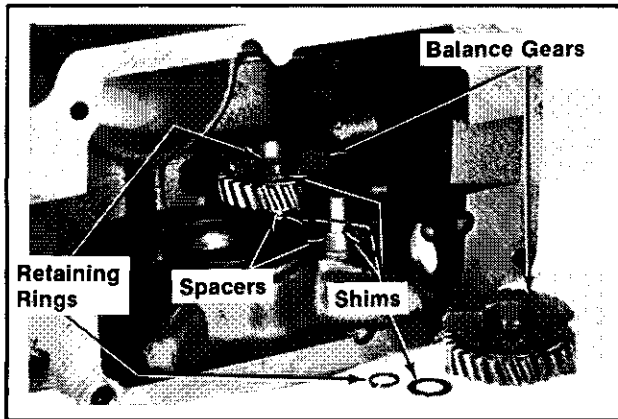

Figure 10B-35. Removing Balance Gears.

REMOVE GOVERNOR GEAR AND CROSS SHAFT

1. Remove the stop pin, copper washer, governor gear, and thrust washer. Refer to Figures 10B-36 and 10B-37.

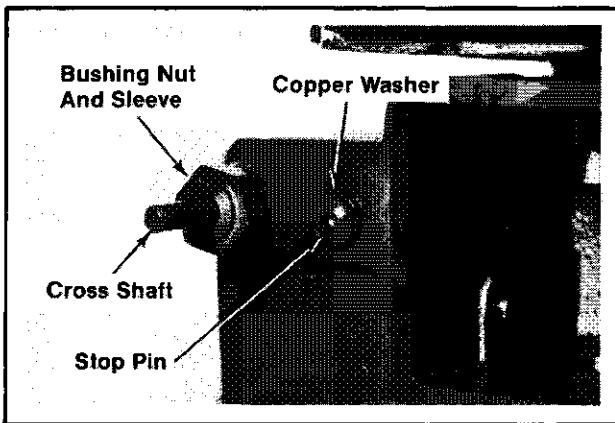

Figure 10B-36. Removing Governor Gear And Cross Shaft.

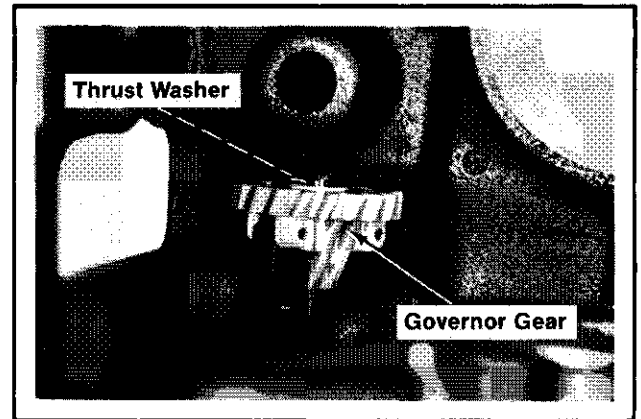

Figure 10B-37. Removing Governor Gear And Cross Shaft.

2. Remove bushing nut and sleeve. Remove cross shaft from inside crankcase.

REMOVE OIL SEALS

1. Remove the oil seals from the crankcase and bearing plate.

REMOVE BEARINGS

1. Press the bearings out of the bearing plate and crankcase.

NOTE: If the bearings have remained on the crankshaft, remove bearing by using a puller.

MAGNUM

Single Cylinder Engine
Service Manual
Models M8, M10, M12
M14, M16
TP-2203-A 3/86

KOHLER
engines

INSPECTION AND REPAIR/RECONDITIONING

All parts should be thoroughly cleaned—dirty parts cannot be accurately gauged or inspected properly for wear or damage. There are many commercially available cleaners that quickly remove grease, oil and grime accumulation from engine parts. If such a cleaner is used, follow the *manufacturers instructions carefully*, and make sure that all of the cleaner is removed before the engine is reassembled and placed in operation. Even small amounts of these cleaners quickly break down the lubricating properties of engine oils.

Refer to TP-2150, A Guide To Engine Rebuilding, for additional information. Also available is TP-2159, Measurement Guide, which you can use to record your inspection results.

FLYWHEEL Inspection

Inspect the flywheel for cracks, and the flywheel keyway for damage. Replace flywheel if cracked. Replace the flywheel, the crankshaft, and the key if flywheel key is sheared or the keyway damaged.

Inspect ring gear for cracks or damage. Kohler no longer provides ring gears as a serviceable part. Replace flywheel if the ring gear is damaged.

CYLINDER HEAD Inspection

Blocked cooling fins often cause localized "hot spots" which can result in a "blown" cylinder head gasket. If the gasket fails, high temperature gases can burn away portions of the aluminum alloy head. A cylinder head in this condition must be replaced.

If the cylinder head appears in good condition, use a block of wood or plastic scraper to scrape away carbon deposits. Be careful not to nick or scratch the aluminum, especially in gasket seating area.

The cylinder head should also be checked for flatness. Use a feeler gauge and a surface plate or a piece of plate glass to make this check. Cylinder head flatness should not vary more than **.003"**; if it does, replace the cylinder head (refer to Figure 11-1).

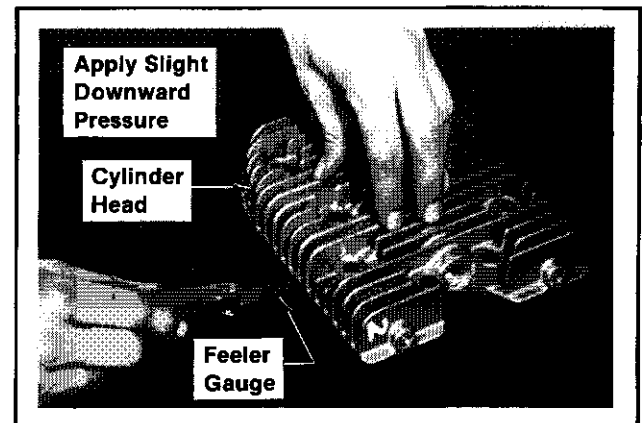

Figure 11-1. Checking Cylinder Head Flatness.

NOTE: Measure cylinder head flatness between each cap screw hole.

In cases where the head is warped or burned, it will also be necessary to replace the head screws. The high temperatures that warped or burned the head could have made the screws ductile which will cause them to stretch when tightened.

CYLINDER BLOCK

Inspection And Reconditioning

Check all gasket surfaces to make sure they are free of gasket fragments. Gasket surfaces must also be free of deep scratches or nicks.

Scoring of the Cylinder Wall: Unburned fuel, in severe cases, can cause scuffing and scoring of the cylinder wall. As raw fuel seeps down the cylinder wall, it washes the necessary lubricating oils off the piston and cylinder wall so that the piston rings make metal to metal contact with the wall. Scoring of the cylinder wall can also be caused by localized hot spots resulting from blocked cooling fins or from inadequate or contaminated lubrication.

If the cylinder bore is badly scored, excessively worn, tapered, or out of round, resizing is necessary. Use an inside micrometer to determine amount of wear (see Specifications, Tolerances, And Special Torque Values, Section 1), then select the nearest suitable oversize of either .003", .010" or .030". Resizing to one of these oversizes will allow usage of the available oversize piston and ring assemblies. Initially, resize using a boring bar, then use the following procedures for honing the cylinder:

Honing

While most commercially available cylinder hones can be used with either portable drills or drill presses, the use of a low speed drill press is preferred as it facilitates more accurate alignment of the bore in relation to the crankshaft crossbore. Honing is best accomplished at a drill speed of about 250 RPM and 60 strokes per minute. After installing coarse stones in hone, proceed as follows:

1. Lower hone into bore and after centering, adjust so that stones are in contact with the cylinder wall. Use of a commercial cutting-cooling agent is recommended.
2. With the lower edge of each stone positioned even with the lowest edge of the bore, start drill and honing process. Move hone up and down while resizing to prevent formation of cutting ridges. Check size frequently.

NOTE: Keep in mind the temperatures caused by honing may cause inaccurate measurements. Make sure the block is cool when measuring.

3. When bore is within .0025" of desired size, remove coarse stones and replace with burnishing stones. Continue with burnishing stones until within .0005" of desired size and then use finish stones (220-280 grit) and polish to final size. A crosshatch should be observed if honing is done correctly. The crosshatch should intersect at approximately 23-33° off the horizontal. Too flat an angle could cause the rings to skip and wear excessively, too high an angle will result in high oil consumption (see Figure 11-2).

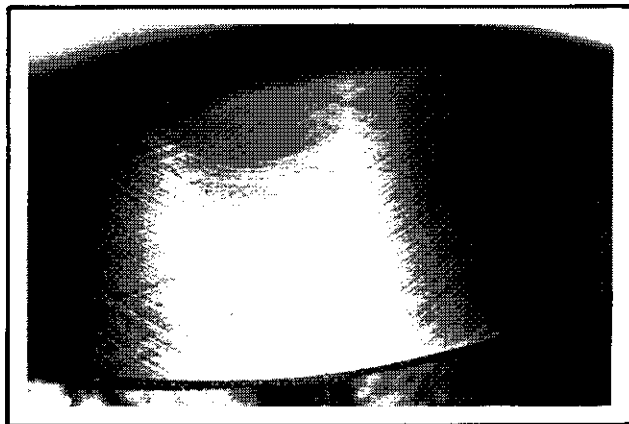

Figure 11-2. Cylinder Bore Crosshatch After Honing.

4. After resizing, check the bore for roundness, taper, and size. Use an inside micrometer, telescoping gauge, or bore gauge to take measurements (refer to Figure 11-3). The measurements should be taken at three locations in the cylinder—at the top, middle, and bottom. Two measurements should be taken (perpendicular to each other) at each of the three locations.

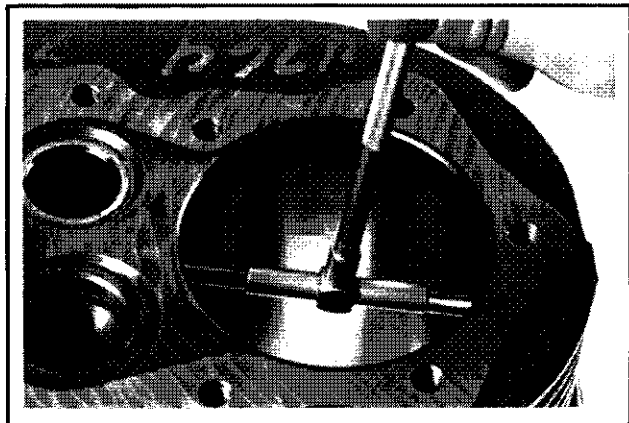

Figure 11-3. Measuring Cylinder Bore.

5. Thoroughly clean cylinder wall with soap and hot water. Use a scrub brush to remove all traces of boring/honing debris. Dry thoroughly and apply a light coat of SAE 10 oil to prevent rust.

Measuring Piston-to-Bore Clearance

Before installing the piston into the cylinder bore, it is necessary that the clearance be accurately checked. This step is often overlooked, and if the clearances are not within specifications, generally engine failure will result.

NOTE: Do not use a feeler gauge to measure piston-to-bore clearance—it will yield inaccurate measurements. Use a micrometer.

The following procedures should be used to accurately measure the piston to bore clearance:

1. Use a micrometer and measure the diameter of the piston as shown in Figure 11-4.

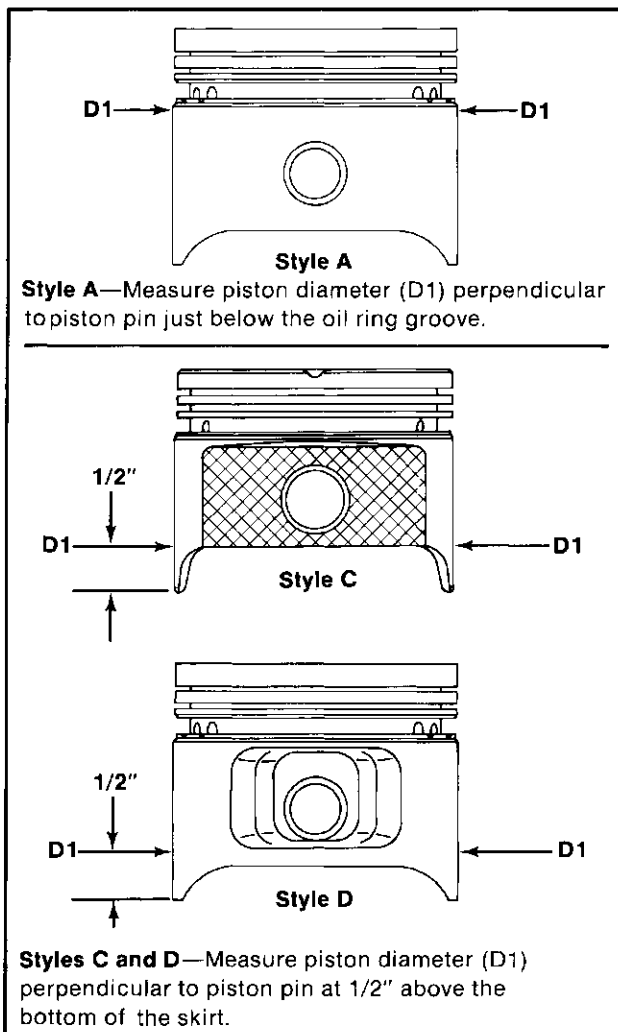

Figure 11-4. Measuring Piston Diameter.

2. Use an inside micrometer, telescoping gauge, or bore gauge and measure the cylinder bore. Take the measurement approximately 2-1/2" below the top of the bore and perpendicular to the piston pin.
3. Piston-to-bore clearance is the difference between the bore and the piston diameter (step 2 minus step 1). Clearance should be: **.007"-.010"** (style **A** piston), **.003"-.005"** (style **C** piston), **.0034"-.0051"** (style **D** piston).

VALVES

Inspection and Service

Carefully inspect valve mechanism parts. Inspect valve springs and related hardware for excessive wear or distortion. Valve spring free height should be at approximately the dimension given in the chart below. Check valves and valve seat area or inserts for evidence of deep pitting, cracks or distortion. Check clearance of valve stems in guides. See Figure 11-5 for valve details and specifications.

Valve Spring Free Height (New).

Model	Intake	Exhaust
M8	1.80"	1.53"
M10, M12	1.80"	1.53"
M14, M16	1.53"	1.53"

Hard starting, or loss of power accompanied by high fuel consumption may be symptoms of faulty valves. Although these symptoms could also be attributed to worn rings, remove and check valves first. After removal, clean valve head, face and stem with power wire brush and then carefully inspect for defects such as warped valve head, excessive corrosion or worn stem end. Replace valves found to be in bad condition. A normal valve and valves in bad condition are shown in the accompanying illustrations.

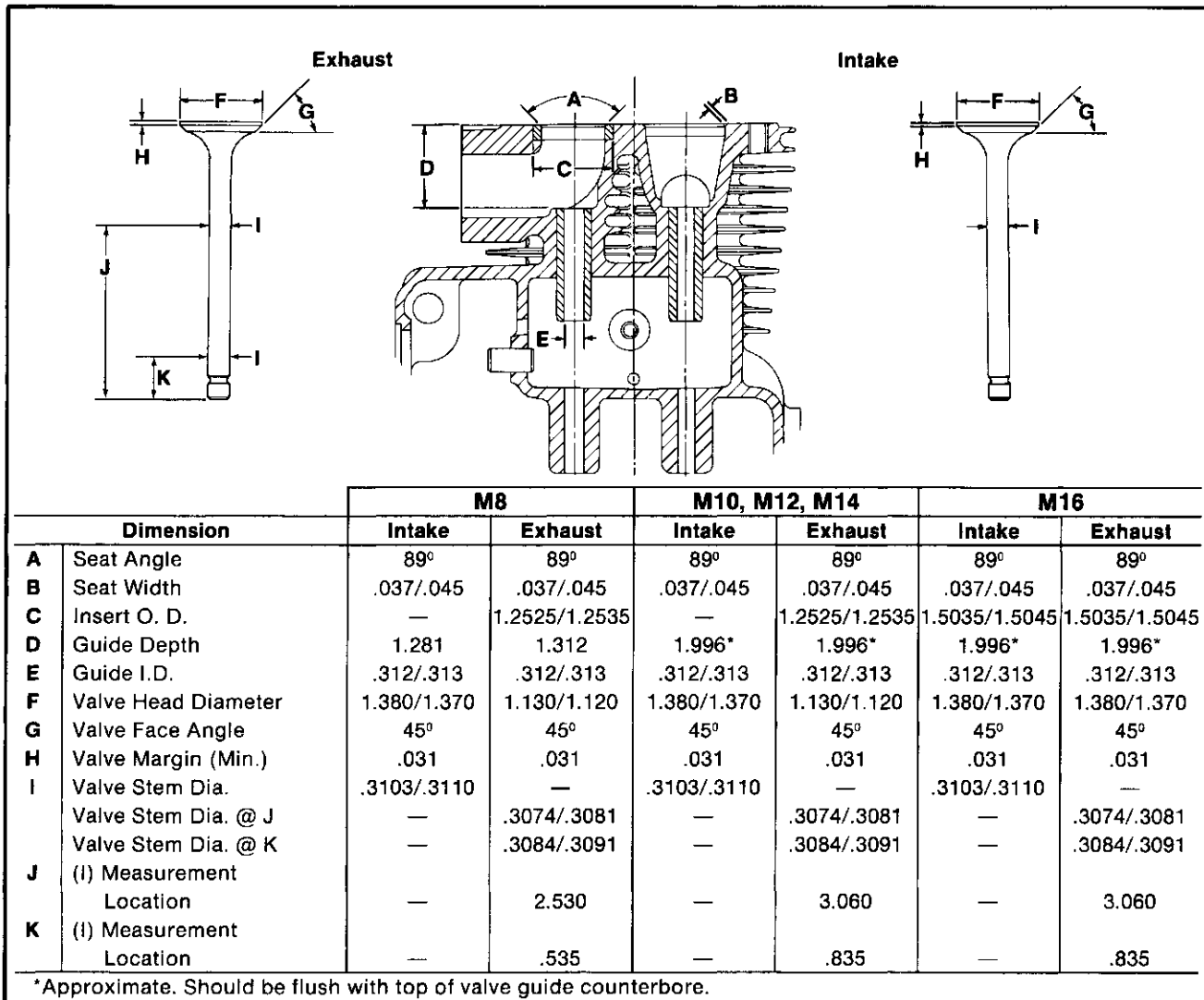
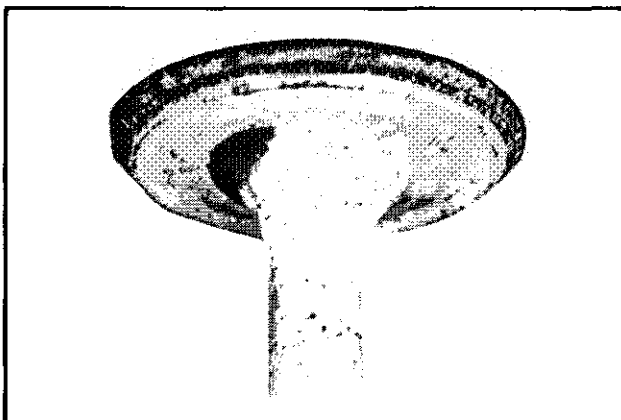
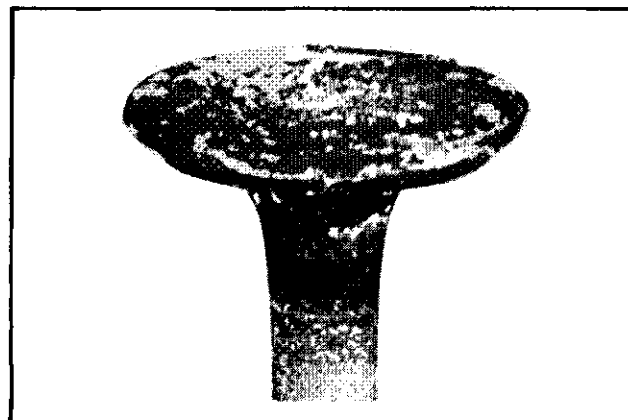

Figure 11-5. Valve Details.



Normal: Even after long hours of operation a valve can be reconditioned and reused if the face and margin are in good shape. If a valve is worn to where the margin is less than 1/32" do not reuse it. The valve shown was in operation for almost 1000 hours under controlled test conditions.



Bad Condition: The valve depicted here should be replaced. Note the warped head; margin damaged and too narrow. These conditions could be attributed to excessive hours or a combination of poor operating conditions.

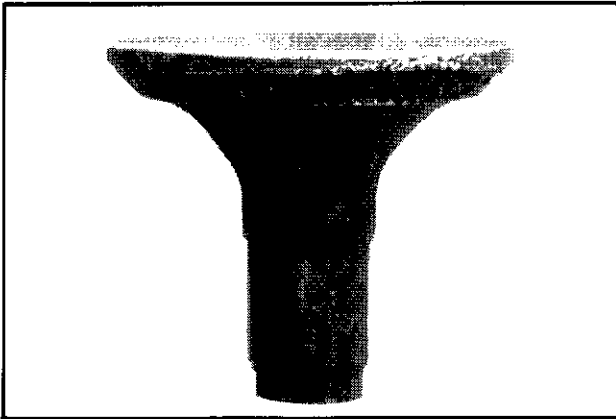

Leakage: A poor grind on face or seat of valve will allow leakage resulting in a burned valve on one side only.



Coking: Coking is normal on intake valves and is not harmful. If the seat is good, the valve could be reused after cleaning.

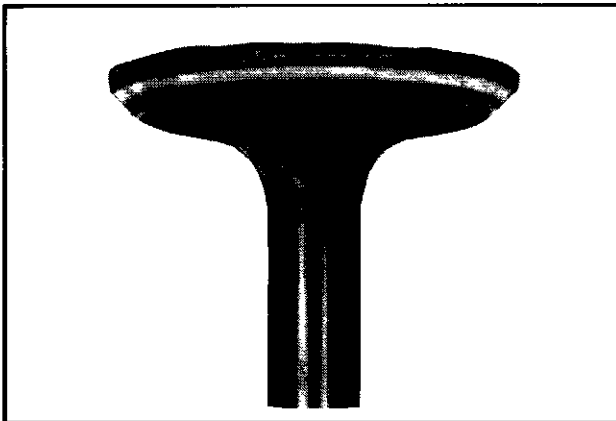

Overheating: An exhaust valve subject to overheating will have a dark discoloration in the area above the valve guide. Worn guides and faulty valve springs may cause this condition. Also check for clogged air intake, blocked fins, and lean fuel mixture when this condition is noted.

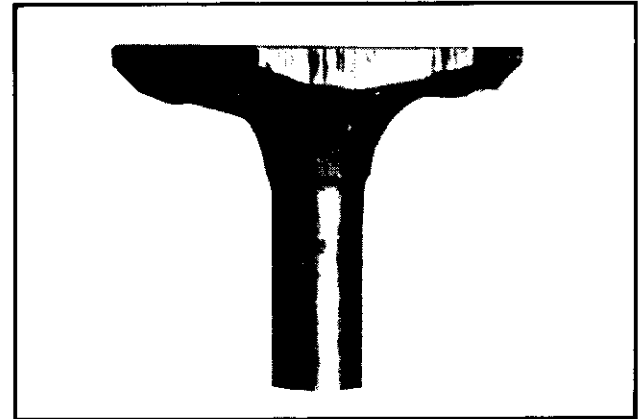

Carbon Cut: Excessive buildup of deposits in the combustion chamber may result in valve damage because deposits can become hard enough to cut the valve. Cleaning of the cylinder head at proper intervals could prevent such damage.

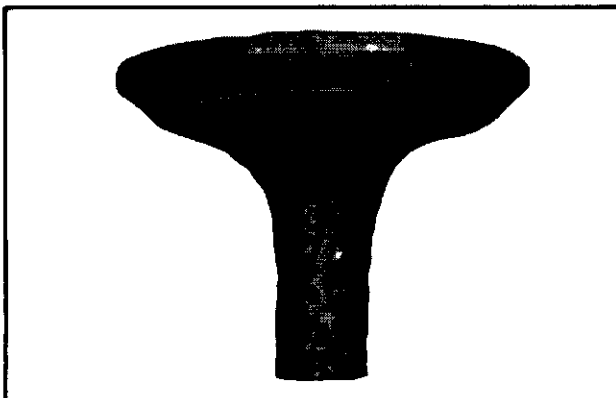

Stem Corrosion: Moisture in fuel or from condensation are the most common causes of valve stem corrosion. Condensation occurs from improper preservation during storage and when engine is repeatedly stopped before it has a chance to reach normal operating temperatures. Replace corroded valves.

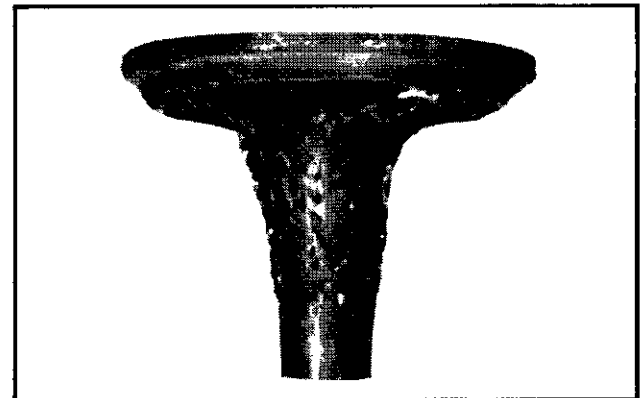

Gum: Gum deposits usually result from using stale gasoline. This condition is often noted in applications where fuel is not drained out of tank during the off season. Gum is a prevalent cause of valve sticking. The cure is to ream the valve guides and clean or replace the valves, depending on their condition.

Valve Guides

If a valve guide is worn beyond specifications, it will not guide the valve in a straight line. This may result in a burnt valve face or seat, loss of compression, and excessive oil consumption.

To check valve guide to valve stem clearance, thoroughly clean the valve guide and, using a split-ball gauge, measure the inside diameter. Then, using an outside micrometer, measure the diameter of the valve stem at several points on the stem where it moves in the valve guide. Use the largest stem diameter to calculate the clearance. If the clearance exceeds **.006** on intake or **.008** on exhaust valves, determine whether the valve stem or the guide is responsible for the excessive clearance.

NOTE: The exhaust valves on these engines have a slightly tapered valve stem to help prevent sticking. Because of the taper, the valve stem must be measured in two places (refer to Figure 11-5) to determine if valve stem is worn. If the valve stem diameter is within specifications, replace the valve guide.

Remove Valve Guide

The valve guides are a tight press fit in the cylinder block. A valve guide removal tool is recommended to remove the guides (refer to "Special Tools" section). To remove valve guide, refer to Figure 11-6 and proceed as follows:

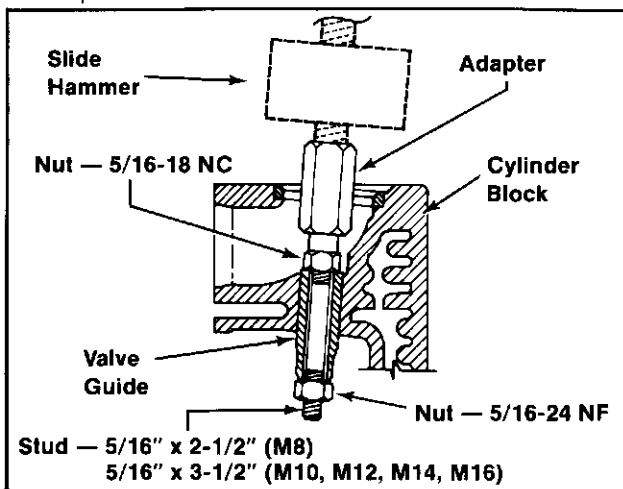

Figure 11-6. Pulling Valve Guide (Typical).

1. Install 5/16-18 NC nut on coarse threaded end of 2-1/2" long stud (M8) or 3-1/2" long stud (M10, M12, M14, M16).
2. Insert other end of stud through valve guide bore and install 5/16-24 NF nut. Tighten both nuts securely.

NOTE: Valve guide must be held firmly by the stud assembly so that all slide hammer force will act on the guide.

3. Assemble the valve guide removal adapter to the stud and then the slide hammer to the adapter.
4. Use the slide hammer to pull the guide out.

Install Valve Guide

To Install valve guide, proceed as follows:

1. Make sure valve guide bore is clean and free of nicks or burrs.
2. Using valve guide driver (refer to "Special Tools" section), align and then press guide in until valve guide driver bottoms on valve guide counterbore.
3. Valve guides are often slightly compressed during insertion. Use a piloted reamer and then a finishing reamer to resize the guide bore to **.3125"**. Refer to Figure 11-7.

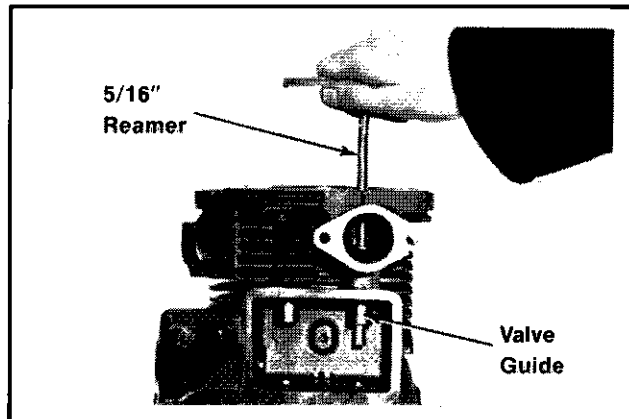

Figure 11-7. Reaming Valve Guide.

Valve Seat Inserts

The intake valve seat is usually machined into the cylinder block, however, certain applications may specify a hard alloy insert. The exhaust valve seat is a replaceable alloy insert. If the seat becomes badly pitted, cracked, or distorted, the insert must be replaced.

The insert is a tight press fit in the cylinder block. A valve seat removal tool is recommended for this job (refer to "Special Tools" section). Since insert removal causes loss of metal in the insert bore area, use only Kohler service replacement inserts, which are slightly larger to provide proper retention in the cylinder block. Make sure new insert is properly started and pressed into bore to prevent cocking of the insert.

Remove Valve Seat Insert

To remove a valve seat insert, refer to Figure 11-8 and proceed as follows:

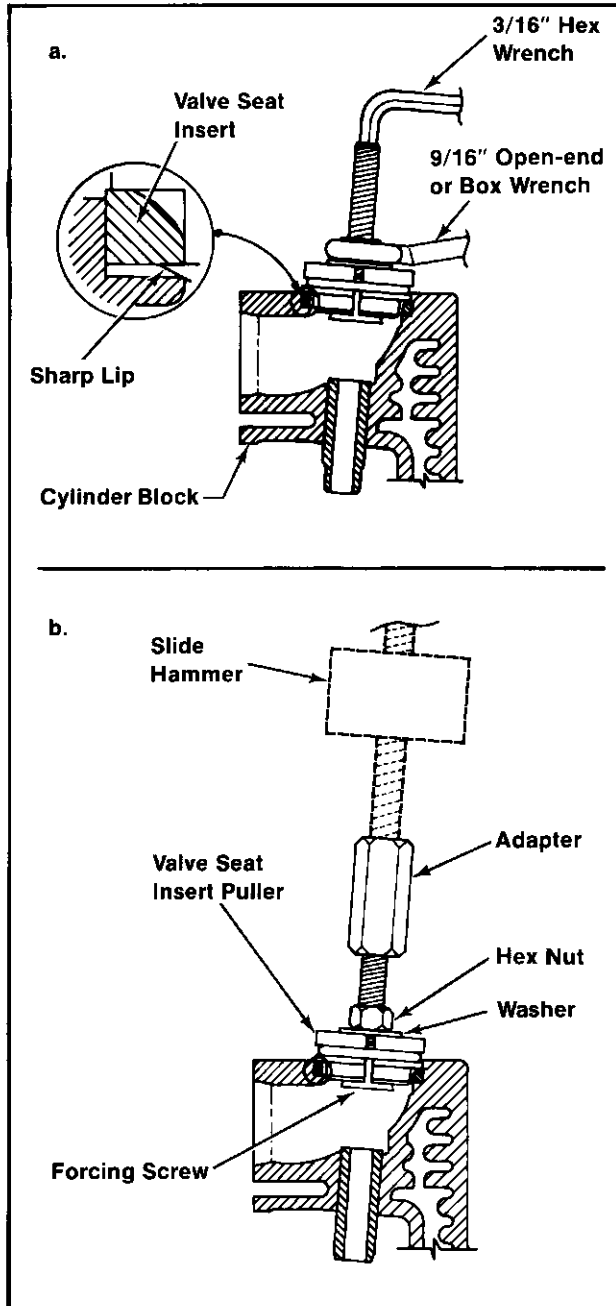

Figure 11-8. Pulling Valve Seat Insert (Typical).

1. Install valve seat puller on forcing screw and lightly secure with washer and nut.
2. Center the puller assembly on valve seat insert.
3. Hold forcing screw with a hex wrench to prevent turning and slowly tighten nut. See Figure 11-8a.

NOTE: Make sure sharp lip on puller (see insert) engages in joint between bottom of valve seat insert and cylinder block counterbore, all the way around.

4. Continue to tighten nut until puller is tight against valve seat insert.
5. Assemble adapter to valve seat puller forcing screw and slide hammer to adapter. See Figure 11-8b.
6. Use slide hammer to remove valve seat insert.

Install Valve Seat Insert

To install valve seat insert, proceed as follows:

1. Make sure valve seat insert bore is clean and free of nicks or burrs.
2. Align valve seat insert in counterbore and using valve seat installer and driver (refer to "Special Tools" section), press seat in until bottomed.
3. Use a standard valve seat cutter (see Figure 11-9) and cut seat to dimensions shown in Figure 11-5.

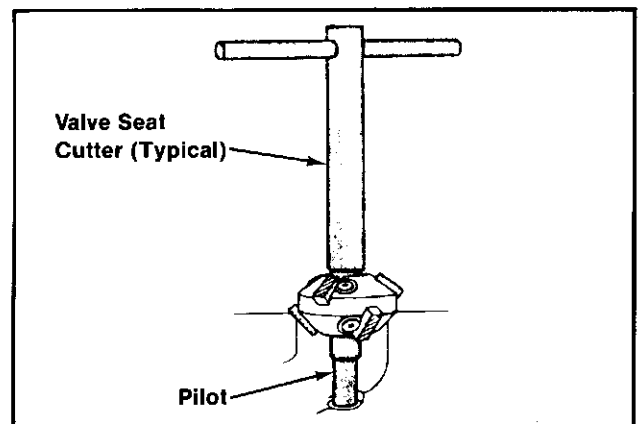

Figure 11-9. Standard Valve Seat Cutter.

Reground or new valves must be lapped in to provide proper fit. Use a hand valve grinder with suction cup for final lapping. Lightly coat valve face with "fine" grade of grinding compound, then rotate valve on seat with grinder. Continue grinding until smooth surface is obtained on seat and on valve face. Thoroughly clean cylinder block in soap and hot water to remove all traces of grinding compound. After drying cylinder block apply a light coating of SAE 10 oil to prevent rusting.

PISTON AND RINGS

Identification

Three different styles of pistons are currently being used in Kohler Magnum engines.

Style "A" pistons were used in M8 engines prior to serial number 1601300012 and are used in all M10, M12, and M14 engines. The style A piston can be identified by its full skirt and by its lack of an installation direction identifier on its crown (a new piston can be installed facing in either direction).

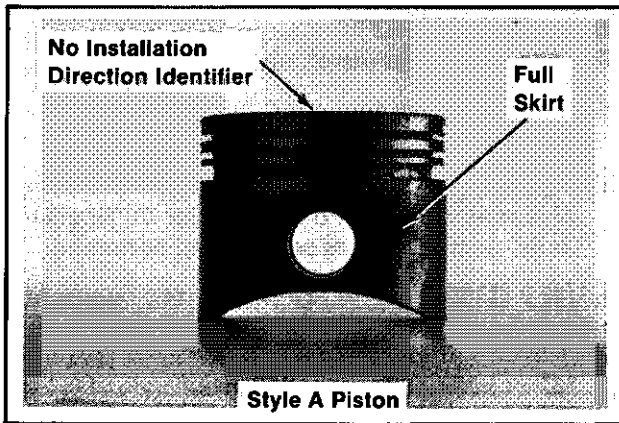

The Style "C" piston is used in the M16 engine and it can be identified by its partial skirt and raised criss-cross design in the recessed area around the piston pin bore. In addition, it has an installation direction identifier (a notch) at its top. The style C piston is to be installed with the notch facing the flywheel.

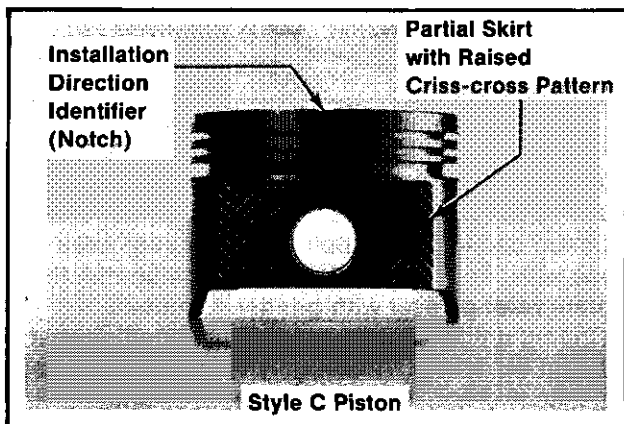

The Style "D" piston has been used in M8 engines from serial number 1601300012 on up. It can be identified by its partial skirt and rectangular recessed area around the piston pin bore. In addition, it has an installation direction identifier, Fly, which is stamped into the top of the piston. The style D piston is to be installed with the arrow of the Fly mark pointing towards the flywheel.

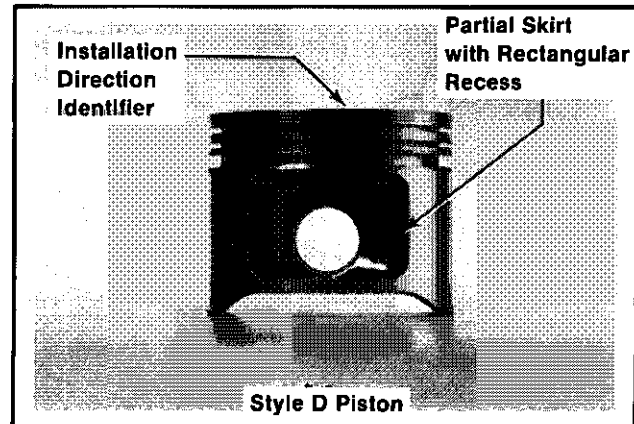

Inspection

Scuffing and scoring of piston and cylinder wall occurs when internal temperatures approach the melting point of the piston. Temperatures high enough to do this are created by friction, which is usually attributed to improper lubrication, and/or overheating of the engine.

Normally, very little wear takes place in the piston boss-piston pin area. If the original piston and connecting rod can be reused after new rings are installed, the original pin can also be reused but new piston pin retainers are required. The piston pin is included as part of the piston assembly — if the pin boss in piston, or the pin are worn or damaged, a new piston assembly is required.

Ring failure is usually indicated by excessive oil consumption and blue exhaust smoke. When rings fail, oil is allowed to enter the combustion chamber where it is burned along with the fuel. High oil consumption can also occur when the piston ring end gap is incorrect because the ring cannot properly conform to the cylinder wall under this condition. Oil control is also lost when ring gaps are not staggered during installation.

When cylinder temperatures get too high, lacquer and varnish collect on piston causing rings to stick which results in rapid wear. A worn ring usually takes on a shiny or bright appearance. Scratches on rings and piston are caused by abrasive material such as carbon, dirt, or pieces of hard metal.

Detonation damage occurs when a portion of the fuel charge ignites spontaneously from heat and pressure shortly after ignition. This creates two flame fronts which meet and explode to create extreme hammering pressures on a specific area of the piston. Detonation generally occurs from using fuels with too low of an octane rating.

Preignition or ignition of the fuel charge before the timed spark can cause damage similar to detonation. Preignition damage is often more severe than detonation damage—often, a hole is quickly burned right through the piston dome. Preignition is caused by a hot spot in the combustion chamber from sources such as: glowing carbon deposits, blocked fins, improperly seated valves or wrong spark plug.

See Figure 11-10 for some common types of piston and ring damage.

Service

Magnum service replacement pistons are available in STD bore size, and in .003", .010", .020", and .030" oversizes. Replacement pistons include new piston ring sets and new piston pins.

Service replacement piston ring sets are also available separately for STD/.003" (same ring set for both sizes), .010", .020" and .030" oversized pistons. Always use new piston rings when installing pistons. Never reuse old rings.

The cylinder bore must be deglazed before service ring sets are used.

Some important points to remember when servicing piston rings:

1. If the cylinder block does not need reboring and if the old piston is within wear limits (refer to

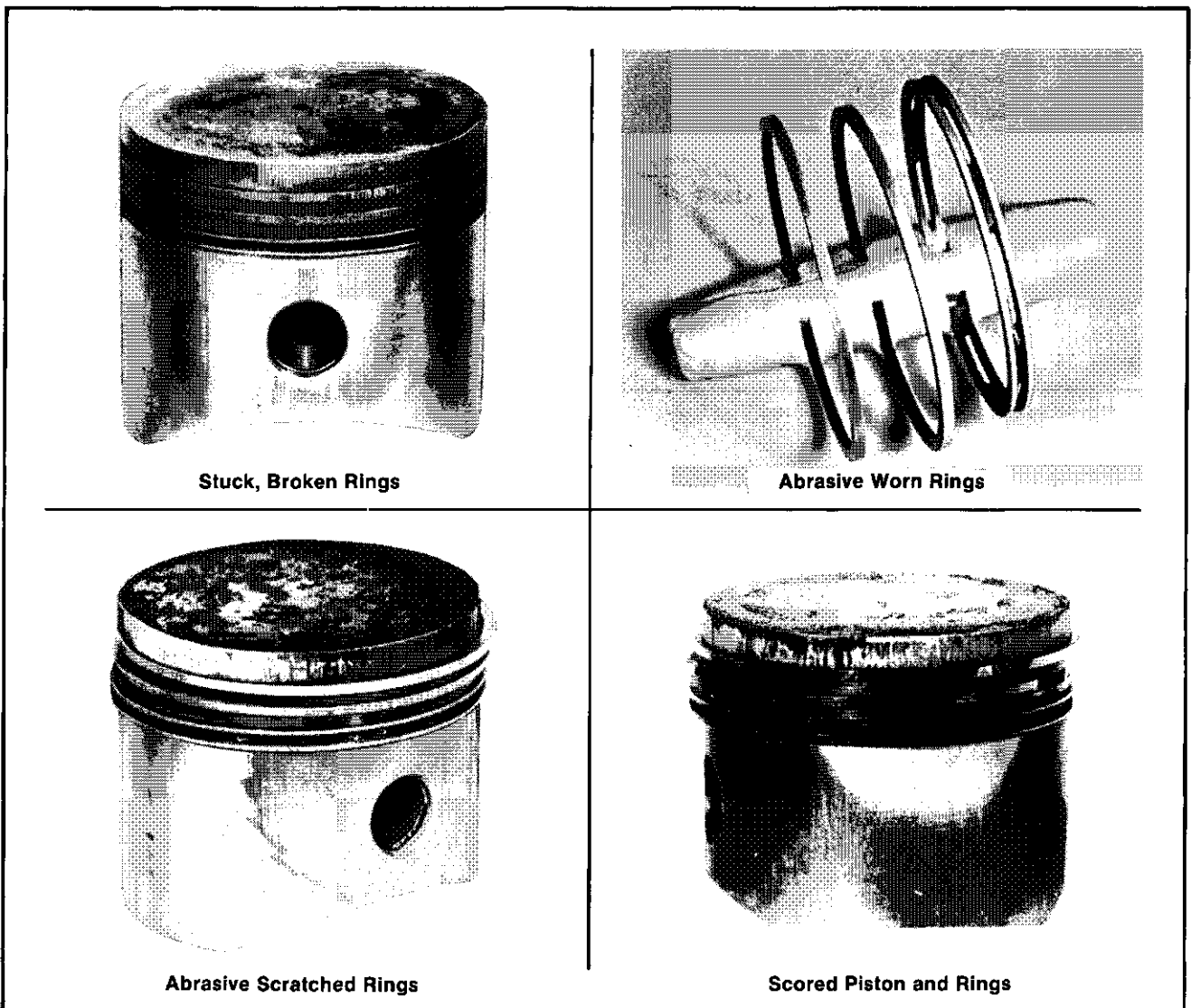
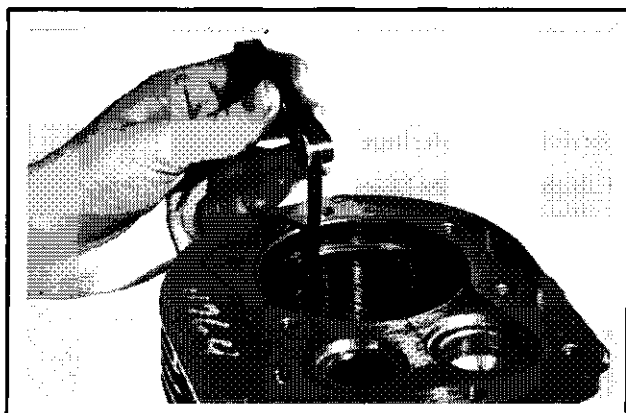

Figure 11-10. Common Types of Piston and Ring Damage.

Section 1, "Specifications, Tolerances And Special Torque Values") and free of score or scuff marks, the old piston may be reused.

2. Remove old rings and clean up grooves. Never reuse old rings.
3. Before installing new rings on piston, place top two rings, each in turn, in its running area in cylinder bore and check end gap (see Figure 11-11).



Model	End Gap	
	New	Used
M8	.007/.017	.007/.027
M10 M12 M14 M16	.010/.020	.010/.030

Figure 11-11. Measuring Piston Ring End Gap.

4. After installing the new compression (top and middle) rings on piston, check piston-to-ring side clearance. Maximum recommended side clearance is **.006"**. If side clearance is greater than **.006"**, a new piston must be used. Refer to Figure 11-12.

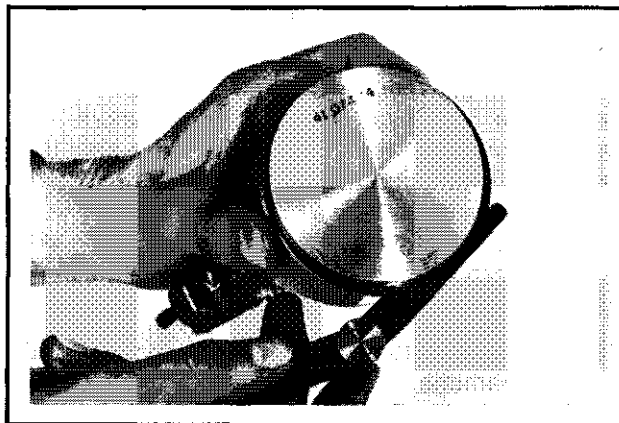

Figure 11-12. Measuring Piston Ring Side Clearance.

Install Piston Rings

To install piston rings, refer to Figure 11-13.

NOTE: Rings must be installed correctly. Ring installation instructions are usually included with new ring sets. Follow instructions carefully. Use a piston ring expander to install rings. Install the bottom (oil control) ring first and the top compression ring last. See Figure 11-13.

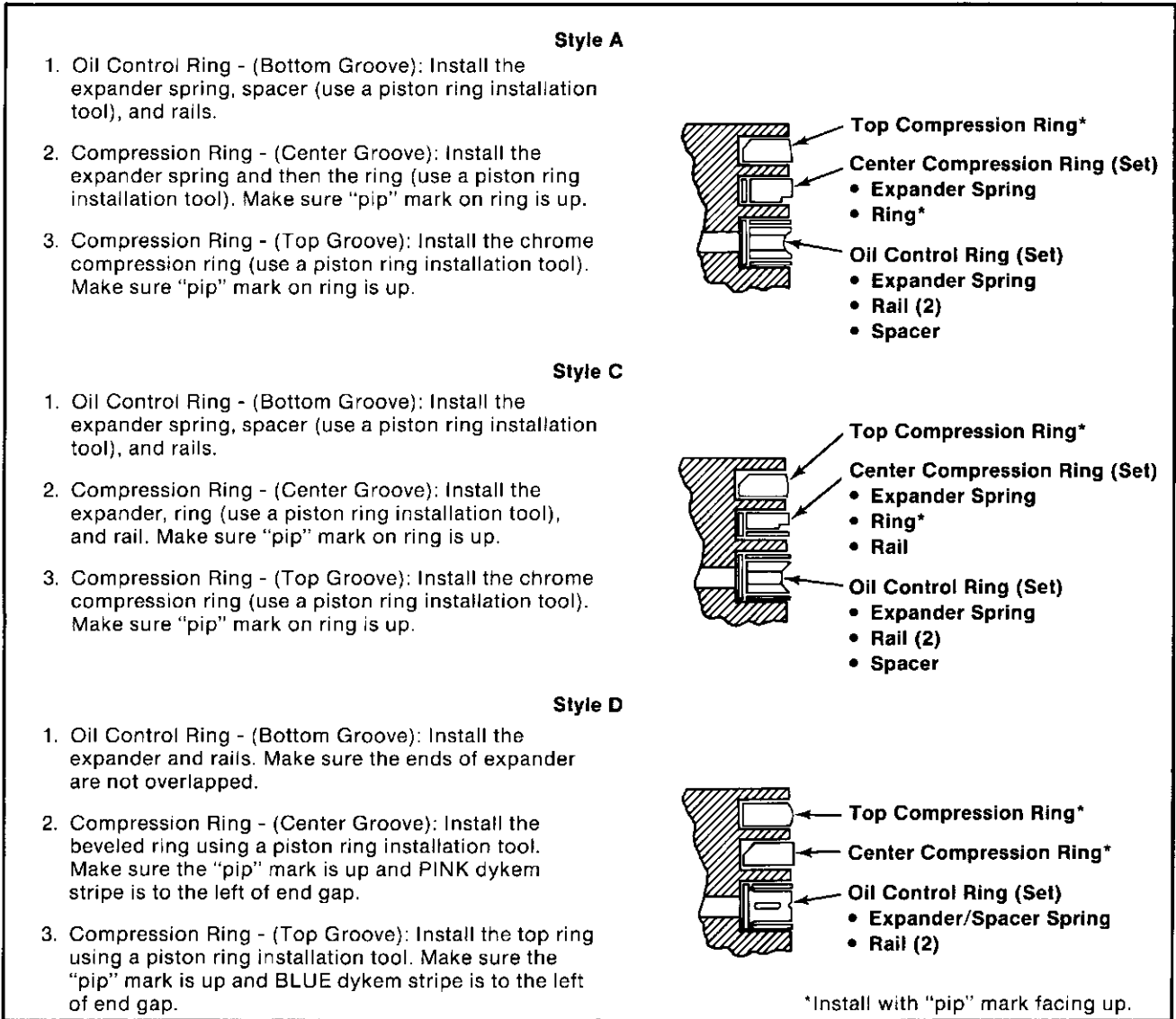

Figure 11-13. Piston Ring Installation.

POSI-LOCK CONNECTING RODS

Posi-Lock connecting rods are used in all Magnum engines. On model M8 engines with the style D pistons (refer to "Piston and Rings, Identification" earlier in this section), the connecting rods have a narrower piston pin end than on the earlier (style A) Posi-Lock connecting rods (refer to Figure 11-14). Therefore, the Posi-Lock connecting rods used with the style D pistons are not interchangeable with the Posi-Lock connecting rods used with style A pistons.

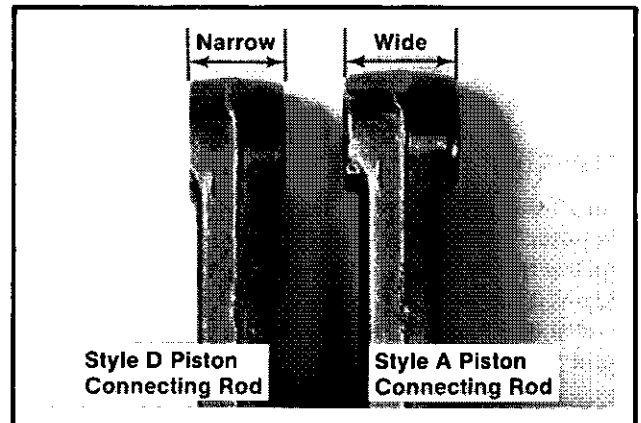

Figure 11-14. Magnum M8 Posi-Lock Connecting Rods.

Inspection and Service

Check bearing area (big end) for excessive wear, score marks, running and side clearances (refer to Section 1, "Specifications, Tolerances And Special Torque Values"). Replace rod and cap if scored or excessively worn.

Service replacement connecting rods are available in STD crankpin size and .010" undersize. The .010" undersize rod can be identified by the drilled hole located in the lower end of the rod shank (refer to Figure 11-15). Always refer to the appropriate parts information to ensure the correct replacements are used.

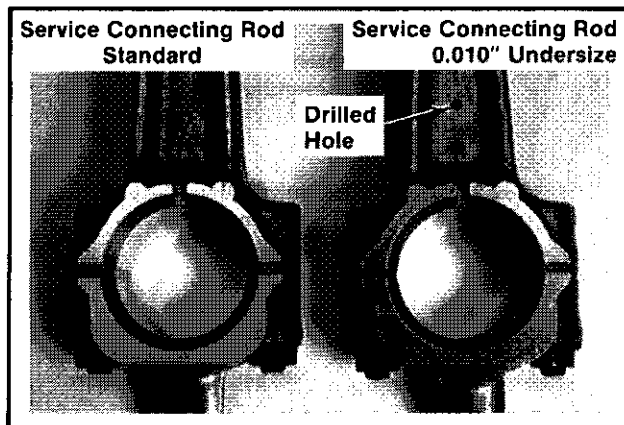

Figure 11-15. Standard and .010" Undersize Connecting Rods.

BALANCE GEARS AND STUB SHAFTS

Most M10, M12, M14, and M16 Magnum engines are equipped with a balance gear system. M8 Magnum engines do not have balance gears.

The system consists of two gears and spacers (used to control end play) mounted on stub shafts which are pressed into the crankcase. The gears and spacers are held on the shafts with snap-ring retainers. The gears are timed with and driven by the engine crankshaft.

Inspection and Repair

Use a micrometer and measure the stub shaft diameter. If the diameter is less than .4996", replace the stub shaft. Use an arbor press to push old shaft out and new shaft in. Press the new shaft in until it is 1.087/1.097" from stub shaft boss. Refer to Figure 11-16.

Inspect the gears for worn or chipped teeth and for worn needle bearings. Use an arbor press and driver to replace bearings, if required.

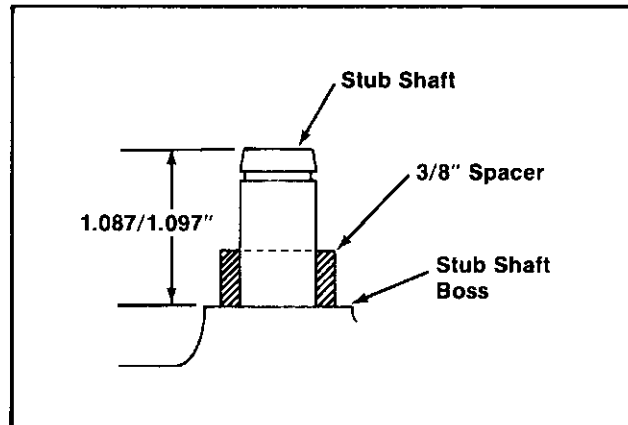

Figure 11-16. Stub Shaft Press Depth.

GOVERNOR GEAR

Inspection

Inspect the governor gear teeth. Look for any evidence of worn, chipped or cracked teeth. If one or more of these problems is noted, replace the governor gear.

CAMSHAFT AND CRANKSHAFT

Inspection and Service

Inspect the gear teeth on both the crankshaft and camshaft. If the teeth are badly worn, chipped or some are missing, replacement of the damaged components will be necessary.

Also, inspect the crankshaft bearings for scoring, grooving, etc. Do not replace bearings unless they show signs of damage or are out of running clearance specifications. If crankshaft turns easily and noiselessly, and there is no evidence of scoring, grooving, etc., on the races or bearing surfaces, the bearings can be resued.

Check crankshaft keyways. If worn or chipped, replacement of the crankshaft will be necessary. Also inspect the crankpin for score marks or metallic pickup. Slight score marks can be cleaned with crocus cloth soaked in oil. If wear limits, as stated in Section 1, "Specifications, Tolerances And Special Torque Values", are exceeded, it will be necessary to either replace the crankshaft or regrind the crankpin to .010" undersize. If reground, a .010" undersize connecting rod (big end) must then be used to achieve proper running clearance. Measure the crankpin for size, taper and out-of-round.

NOTE: If the crankpin is reground, visually check to insure that the fillet blends smoothly with the crankpin surface. Refer to Figure 11-17.

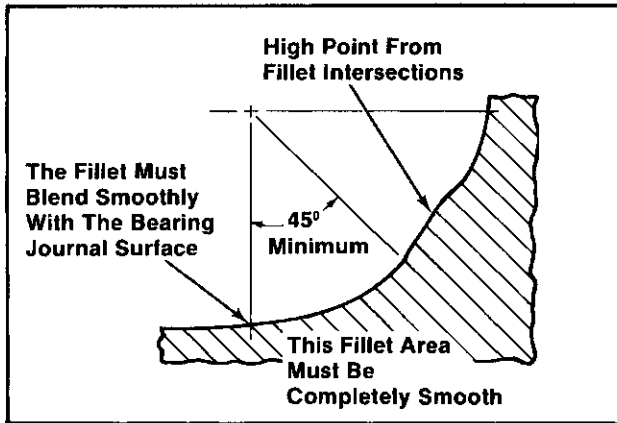

Figure 11-17. Crankpin Fillets.

MAGNUM

Single Cylinder Engine
Service Manual

Models M8, M10, M12
M14, M16

TP-2203-A 3/86

KOHLER
Engines

MODEL M8 REASSEMBLY

The following sequence is suggested for complete engine reassembly. This procedure assumes that all components are new or have been reconditioned, and all component subassembly work has been completed. This procedure may have to be varied slightly to accommodate options or special equipment.

CAUTION: Make sure the engine is assembled using all specified torque values, tightening sequences, and clearances. Failure to observe specifications could cause severe engine wear or damage.

1. Install rear bearing.
2. Install governor gear and cross shaft.
3. Install tappets and camshaft.
4. Install crankshaft.
5. Install front bearing.
6. Install fuel line and wiring harness.
7. Install bearing plate.
8. Install oil seals.
9. Install piston rings.
10. Install piston to connecting rod.
11. Install piston/connecting rod.
12. Install oil pan.
13. Install valves.
14. Install stator.
15. Install fan, flywheel, grass screen, and drive cup or rope start pulley.
16. Install ignition module and air baffle.
17. Install cylinder head and spark plug.
18. Install breather components.
19. Install side air baffles, blower housing, and cylinder head baffle.
20. Install fuel tank and brackets.
21. Install solenoid and electric starter.
22. Install retractable starter.
23. Install external governor components, and throttle and choke controls.

24. Install fuel pump.
25. Install carburetor, throttle linkage, and choke linkage.
26. Install rectifier-regulator.
27. Install muffler.
28. Install air cleaner.

INSTALL REAR BEARING

1. Install the rear bearing into crankcase using the #4747 handle and appropriate bearing installer. (Refer to the "Special Tools" section.) Make sure the bearing is bottomed fully, and straight and true in bore. Refer to Figure 12A-1.

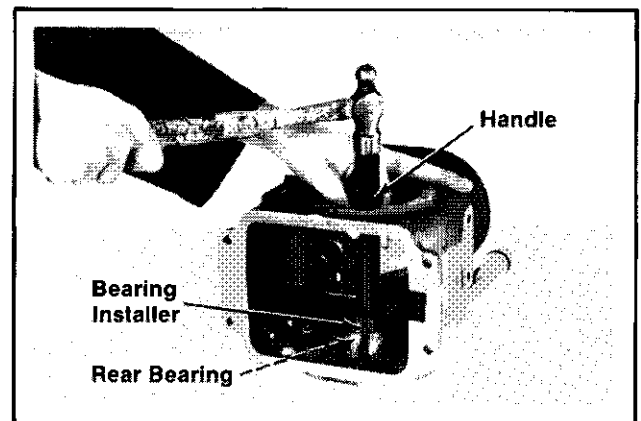

Figure 12A-1. Installing Rear Bearing.

INSTALL GOVERNOR GEAR AND CROSS SHAFT

1. Install the cross shaft, plain washer, and bushing nut. Torque the bushing nut to **100/120 in. lb.** Refer to Figures 12A-2 and 12A-3.

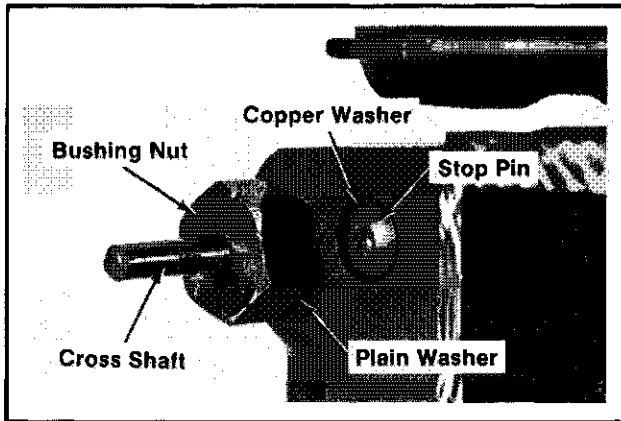

Figure 12A-2. Installing Cross Shaft And Stop Pin.

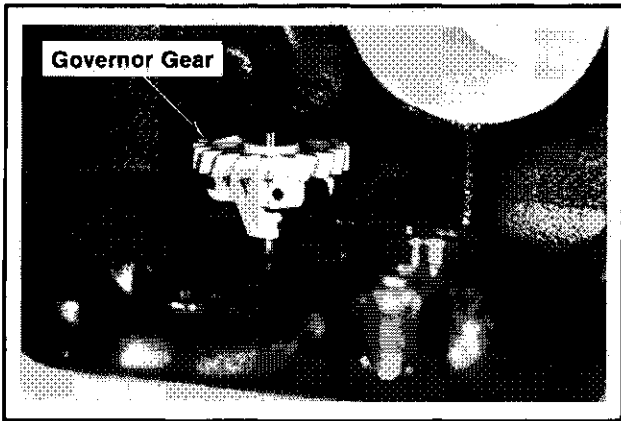

Figure 12A-3. Installing Governor Gear.

2. Install the governor gear, copper washer, and stop pin.

INSTALL TAPPETS AND CAMSHAFT

1. Install the intake valve tappet and exhaust valve tappet into crankcase. (Intake valve tappet towards bearing plate side; exhaust valve tappet towards the PTO side of crankcase.) Refer to Figure 12A-4.



Figure 12A-4. Installing Tappets.

2. Install the camshaft, one .010" shim spacer, and camshaft pin (from bearing plate side). Do not drive the camshaft pin into final position at this time. Refer to Figure 12A-5.

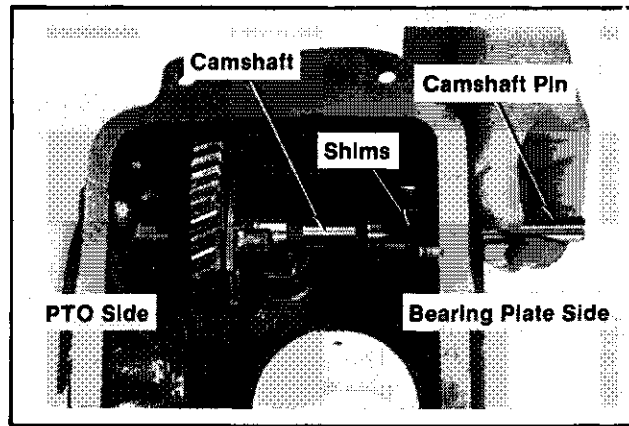

Figure 12A-5. Installing Camshaft.

3. Measure camshaft end play between spacer and crankcase boss using a flat feeler gauge. Refer to Figure 12A-6.

Recommended camshaft end play is $.005"/.010"$. Add or subtract $.005"$ and/or $.010"$ shim spacers as necessary to obtain the proper end play.

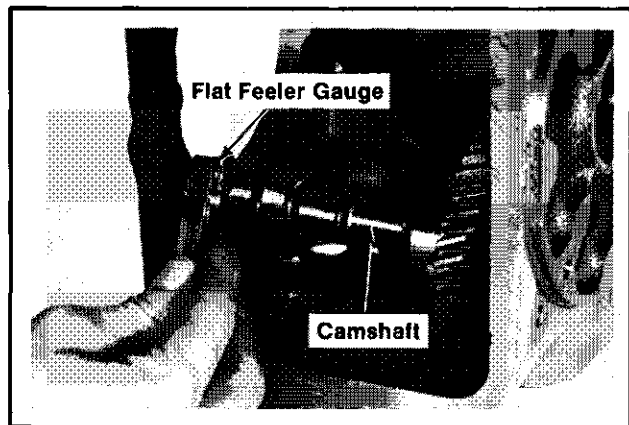

Figure 12A-6. Measuring Camshaft End Play.

4. Drive the camshaft pin into PTO side of crankcase until it is $.275"/.285"$ from machined bearing plate gasket surface. Refer to Figure 12A-7.

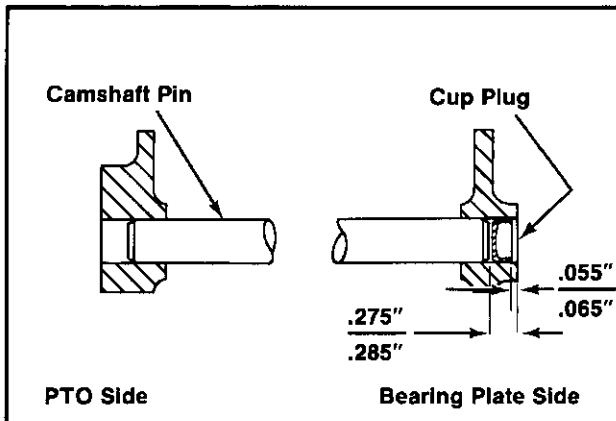

Figure 12A-7. Installing Camshaft Pin And Cup Plug.

5. Apply Loctite® #290 (or equivalent) to the cup plug. Install the cup plug into bore in bearing plate mounting surface to a depth of .055"/.065". Refer to Figures 12A-7 and 12A-8.

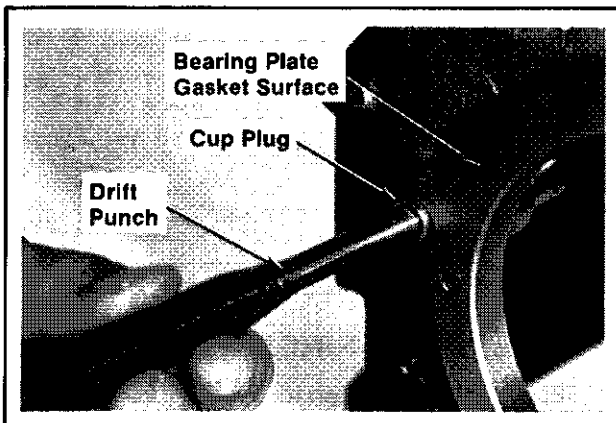

Figure 12A-8. Installing Cup Plug.

INSTALL CRANKSHAFT

1. Lubricate the rear crankshaft bearing surface. Insert the crankshaft through rear bearing.
- NOTE: If the crankshaft and bearing plate have not been separated, position the fuel line and wiring harness between the bearing plate and crankcase before pressing the crankshaft all the way in.
2. Align the timing mark on crankshaft with the timing mark on camshaft. Refer to Figure 12A-9. Press crankshaft into rear bearing. Make sure the camshaft and crankshaft gears mesh and timing marks align while pressing.

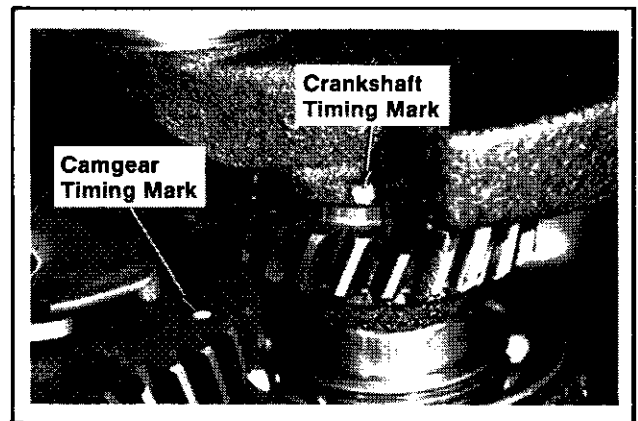

Figure 12A-9. Aligning Crankshaft And Camgear Timing Marks.

INSTALL FRONT BEARING

1. Install the front bearing into bearing plate using the #4747 handle and appropriate bearing installer. (Refer to the "Special Tools" Section.) Make sure the bearing is bottomed fully, and straight and true in bore.

INSTALL FUEL LINE AND WIRING HARNESS

1. Position the fuel line and wiring harness (if so equipped) to crankcase.
2. Adjust the fuel line and wiring harness to their final positions just before securing the bearing plate to crankcase.

INSTALL BEARING PLATE

1. Install 1/4-20 studs into two bearing plate mounting holes. The studs ease locating and assembly of shims, gasket, and bearing plate. Refer to Figure 12A-10.

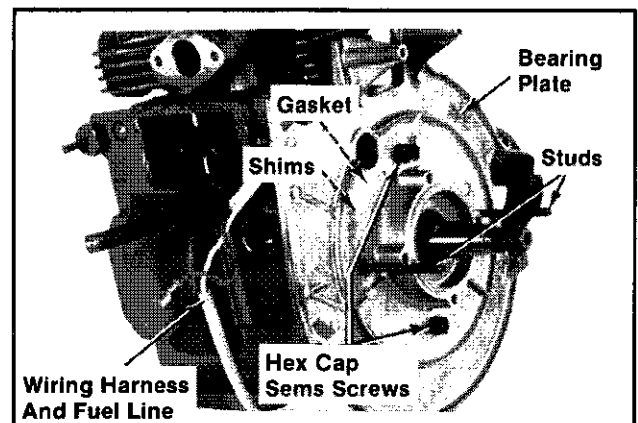

Figure 12A-10. Installing Wiring Harness And Bearing Plate.

- Lubricate the bearing surface of crankshaft and bearing. Install the gasket, two or three .005" shims (as required)*, and bearing plate over studs.

*NOTE: Crankshaft end play is determined by the thickness of the gasket and shims between crankcase and bearing plate. Check the end play after bearing plate is installed.

- Install two hex cap sems screws and hand tighten. Remove the locating studs, and install remaining two hex cap sems screws and hand tighten.
- Position the wiring harness and fuel line in their final positions as marked during disassembly.
- Tighten the screws evenly, drawing bearing plate to crankcase. Torque the screws to **115 in. lb.**
- Check the crankshaft end play between the inner bearing race and shoulder of crankshaft using a flat feeler gauge. Recommended total end play is **.002"-.023"**. Refer to Figure 12A-11.

If measured end play is not within limits, remove the bearing plate and remove or install shims as necessary.

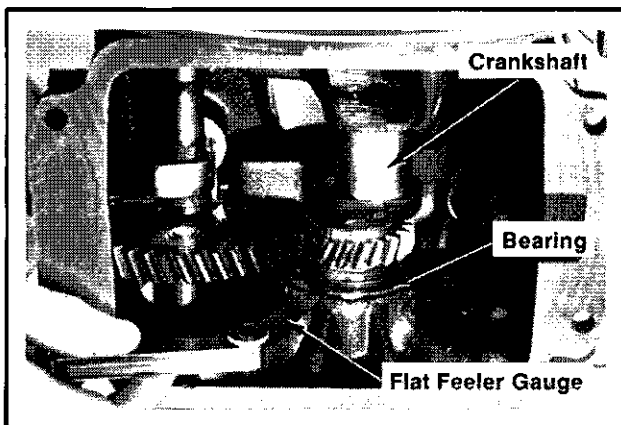

Figure 12A-11. Measuring Crankshaft End Play.

INSTALL OIL SEALS

- Slide the appropriate seal sleeves over crankshaft. (Refer to the "Special Tools" section.) Generously lubricate the lips of oil seals with light grease. Slide the oil seals over sleeves.
- Use the #11795 handle and appropriate seal drivers, install oil seals to the following depths:

Front Oil Seal (Bearing Plate)—1/32"
Rear Oil Seal (Crankcase PTO End)—1/8"
Tolerance on seal position—+3/64"; -1/64"

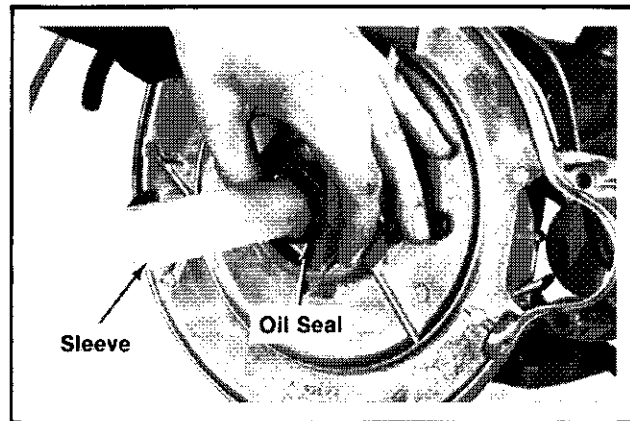

Figure 12A-12. Installing Oil Seals Using Sleeve.

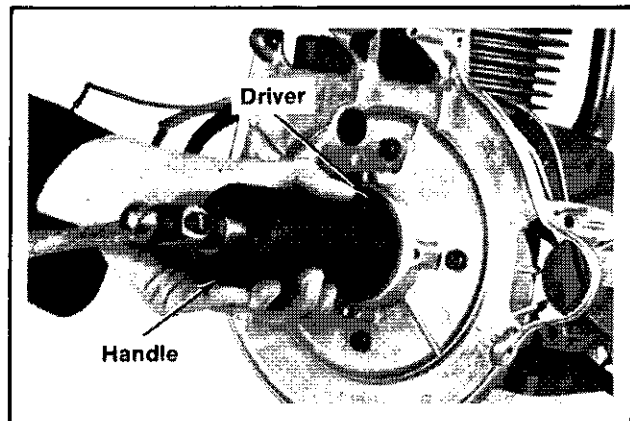

Figure 12A-13. Installing Oil Seals Using Driver.

INSTALL PISTON RINGS

NOTE: For detailed piston inspection procedures, and piston ring installation procedure, refer to the "Inspection And Repair/Reconditioning" section.

INSTALL PISTON TO CONNECTING ROD

On "Style A" Pistons

- Install wrist pin and retainers.

On "Style D" Pistons

CAUTION: Proper orientation of the piston to connecting rod is extremely important. Improper orientation may cause extensive wear or damage.

- Orient the piston and connecting rod so the "Fly" symbol on piston and match marks on connecting rod are facing the same direction.
- Install wrist pin and retainers. Refer to Figure 12A-14.

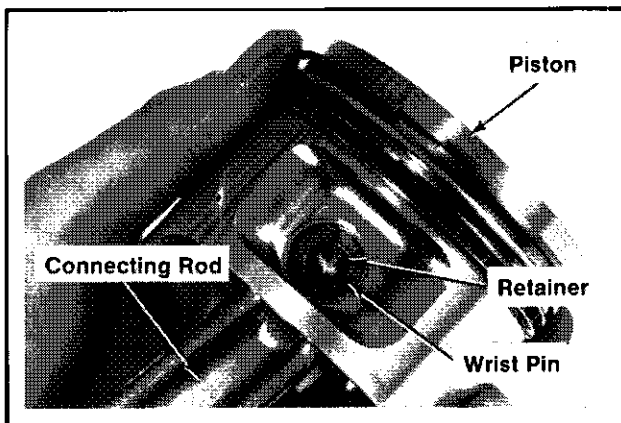

Figure 12A-14. Installing Piston to Connecting Rod (Style "D" Piston Shown).

INSTALL PISTON/CONNECTING ROD

CAUTION: Proper orientation of the piston/connecting rod inside engine is extremely important. Improper orientation may cause extensive wear or damage.

1. Stagger the piston rings in grooves until end gaps are 120° apart.
2. Lubricate the piston and rings with engine oil. Install a piston ring compressor around piston. Refer to Figure 12A-15.

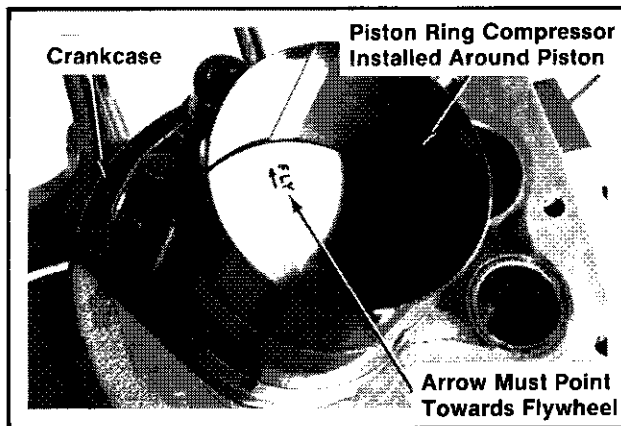

Figure 12A-15. Installing Pistons.

3. Orient the "Fly" mark and match marks on connecting rod towards the flywheel end of crankshaft. Gently push the piston/connecting rod into bore—do not pound on piston.
4. Lubricate the crankshaft and connecting rod journal surfaces with engine oil. Install the connecting rod cap—make sure the match marks are aligned and the oil hole is towards camshaft. Refer to Figure 12A-16.

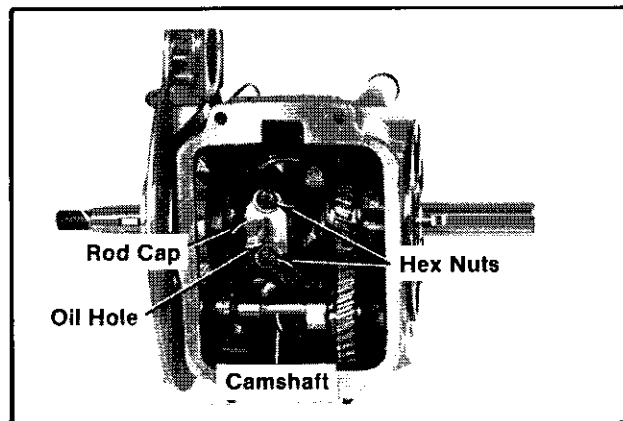

Figure 12A-16. Installing Connecting Rod Cap.

Install the hex nuts and torque in increments as follows:

New Service Rod	Used/Reinstalled Rod
140 in. lb.	100 in. lb.

CAUTION: To prevent damage to connecting rod and engine, do not overtorque—loosen—and retorque the hex nuts on Posi-Lock connecting rods. Torque nuts, in increments, directly to the specified values.

5. Rotate the crankshaft until piston is at top dead center in bore to protect dipper on connecting rod.

INSTALL OIL PAN

1. Install the gasket, oil pan, solenoid bracket, and hex cap sems screws to starter side of oil pan. Refer to Figure 12A-17.

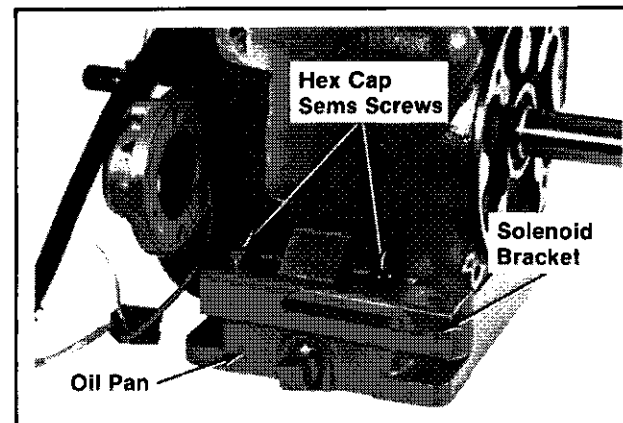

Figure 12A-17. Installing Solenoid Bracket And Oil Pan.

2. Install the handle bracket, plain washers, split lock washers and hex nuts to studs on carburetor side of oil pan. Refer to Figure 12A-18.

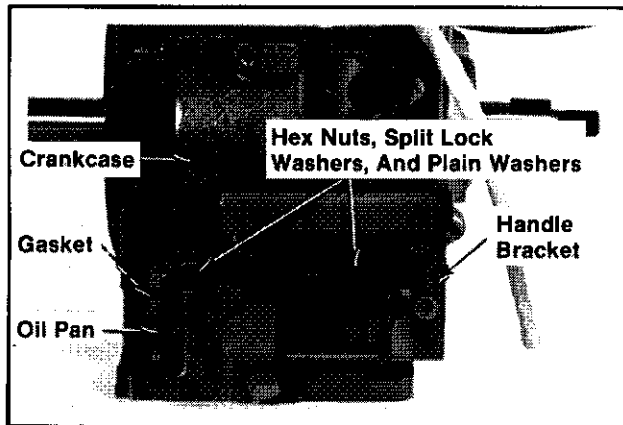

Figure 12A-18. Installing Handle Bracket And Oil Pan.

INSTALL VALVES

1. Rotate the crankshaft until piston is at top dead center of compression stroke.
2. Install the valves and measure valve-to-tappet clearance using a flat feeler gauge. Refer to Figure 12A-19.

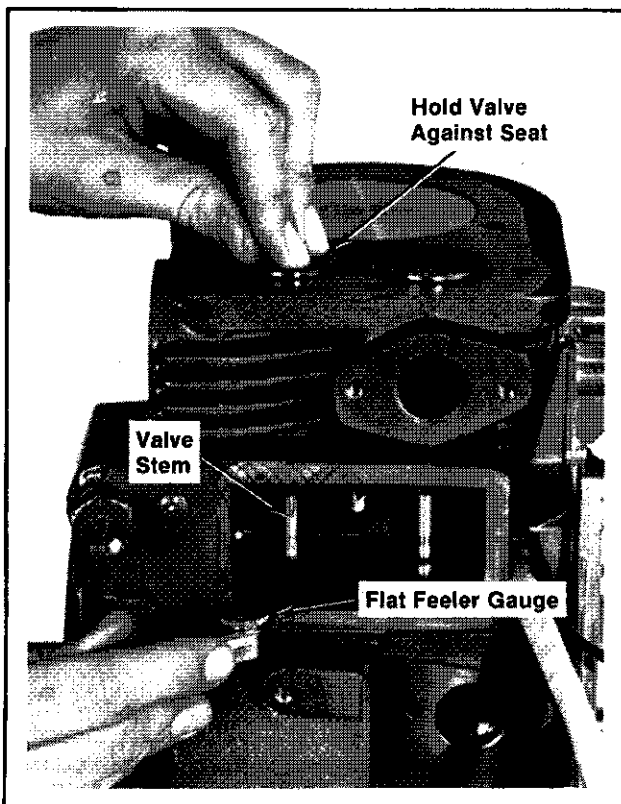

Figure 12A-19. Measuring Valve-To-Tappet Clearance.

NOTE: Valve faces and seats must be lapped-in before checking/adjusting valve clearance.

Valve-to-tappet cold clearance:

Intake Valve	Exhaust Valve
.006"/.008"	.017"/.019"

3. Adjust valve-to-tappet clearance, as necessary.

If clearance is too small, grind end of valve stems until correct clearance is obtained. Make sure stems are ground perfectly flat and smooth.

If clearance is too large, replace the valves and recheck clearance.

NOTE: Large clearances can also be reduced by grinding the valves and/or valve seats. Refer to the "Inspection And Repair/Reconditioning" section for valve specifications.

4. Install the valve springs (close coils to top), intake valve spring retainer, exhaust valve rotator, and valves. Refer to Figure 12A-20.

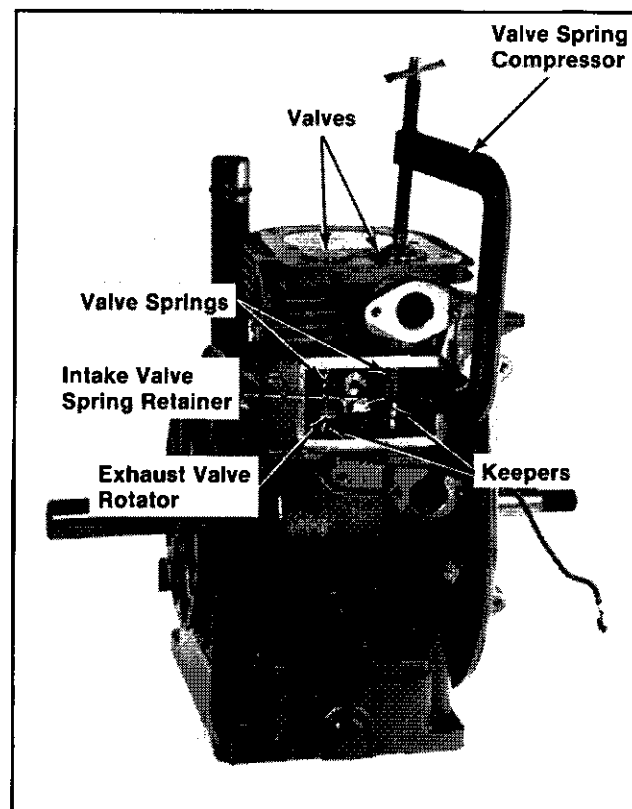

Figure 12A-20. Installing Valves.

NOTE: Some models use a valve rotator on both valves.

5. Compress the springs using a valve spring compressor and install keepers.

INSTALL STATOR

1. Route the leads through hole in bearing plate. Install the stator and pan head screws. Refer to Figure 12A-21.

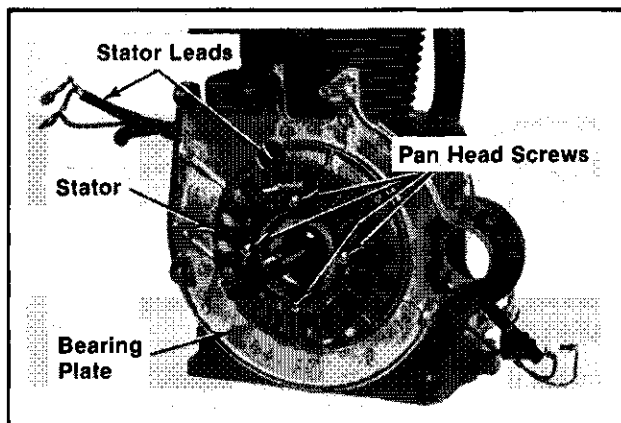

Figure 12A-21. Installing Stator.

2. Insert the stator leads into outer positions of connector body.

INSTALL FAN, FLYWHEEL, GRASS SCREEN, AND DRIVE CUP OR ROPE START PULLEY

WARNING: Damaging Crankshaft and Flywheel



Could Cause Personal Injury!

Using improper procedures to install the flywheel can crack or damage the crankshaft and/or flywheel. This not only causes extensive engine damage, but also is a serious threat to the safety of persons nearby, since broken fragments could be thrown from the engine. Always observe and use the following precautions and procedures when installing the flywheel:

- CAUTION: A. Before installing the flywheel, make sure the crankshaft taper and flywheel hub are clean, dry, and completely free of lubricants. The presence of lubricants can cause the flywheel to be overstressed and damaged when the cap screw is torqued to specification.

- B. Make sure square flywheel key is installed only in the flat area of keyway, not in the rounded area. The flywheel can become cracked or damaged if the key is installed in the rounded area of keyway.
- C. Always use the flywheel strap wrench to hold flywheel when tightening flywheel fastener. Do not use any type of bar or wedge between the cooling fins or flywheel ring gear, as these parts could become cracked or damaged.

1. Install the spacers, fan and hex flange screws. Torque screws to **115 in. lb.** Refer to Figure 12A-22.

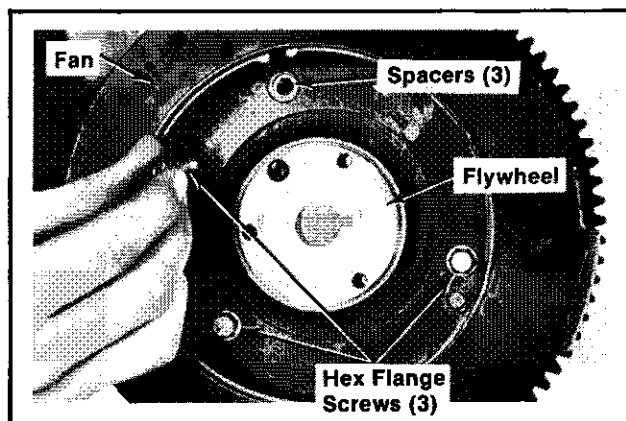

Figure 12A-22. Installing Fan To Flywheel.

2. Place the flywheel on crankshaft. Install the grass screen, and drive cup or rope start pulley as follows:

Rope Start Models

- A. Refer to Figure 12A-23. Install rope pulley, plain washer, and hex nut (lubricate threads with oil). Hold flywheel with strap wrench and torque hex nut to **85/90 ft. lb.**

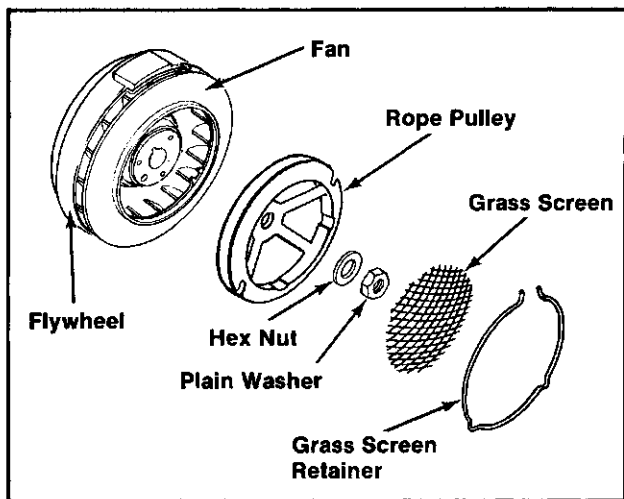

Figure 12A-23. Installing Flywheel, Rope Pulley, And Grass Screen — Rope Start Models.

B. Install grass screen and grass screen retainer.

Retractable Start Models

A. Install the grass screen to fan. Refer to Figure 12A-24.

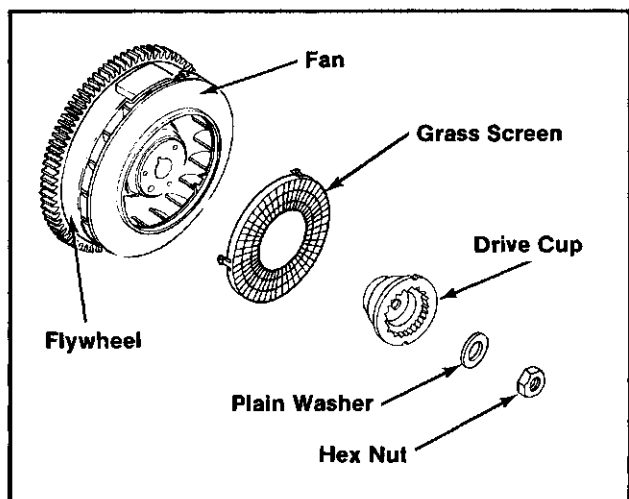

Figure 12A-24. Installing Flywheel, Grass Screen, And Drive Cup — Retractable Start Models.

B. Install the drive cup, plain washer, and hex nut (lubricate threads with oil). Hold the flywheel with strap wrench and torque hex nut to **85/90 ft. lb.**

Electric Start Models

A. Refer to Figure 12A-25. Install the plain washer and hex nut (lubricate threads with oil). Hold the flywheel with strap wrench and torque hex nut to **85/90 ft. lb.**

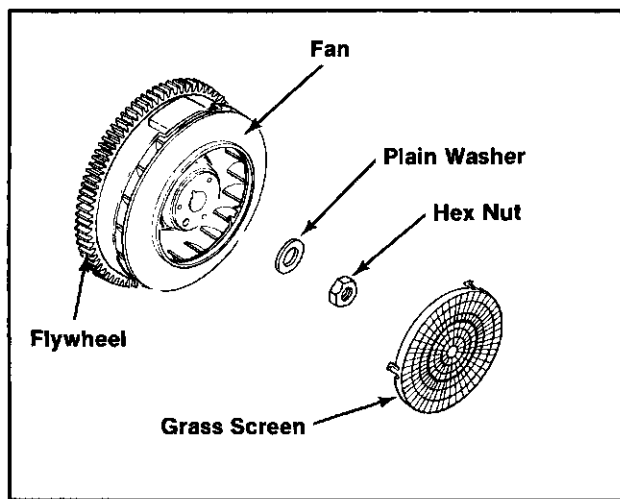

Figure 12A-25. Installing Flywheel And Grass Screen — Electric Start Models.

B. Install the grass screen to fan.

INSTALL IGNITION MODULE AND AIR BAFFLE

1. Install the module, plain washers, and hex cap screws. Move the module as far from flywheel/magnet as possible. Tighten the hex cap screws slightly. Refer to Figure 12A-26.

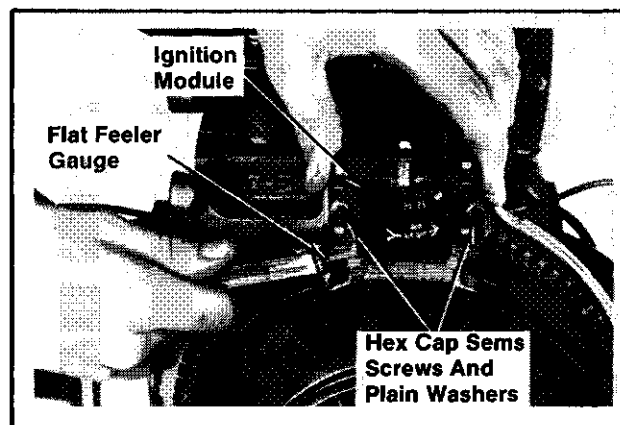

Figure 12A-26. Installing Ignition Module.

2. Insert a .018" flat feeler gauge or shim stock between magnet and module. Loosen hex cap screws so magnet pulls module down. Tighten hex cap screws to **32 in. lb.** Remove feeler gauge or shim stock. Due to the pull of the magnet the bearing plate will flex slightly. The magnet-to-module air gap should be within the range of **.012"/.016"**.

3. Rotate the flywheel back and forth; check to make sure magnet does not strike module. Check the gap with feeler gauge and readjust if necessary.

4. Install the air baffle over module. Install the kill lead and high-tension lead into slots in baffle. Refer to Figure 12A-27.

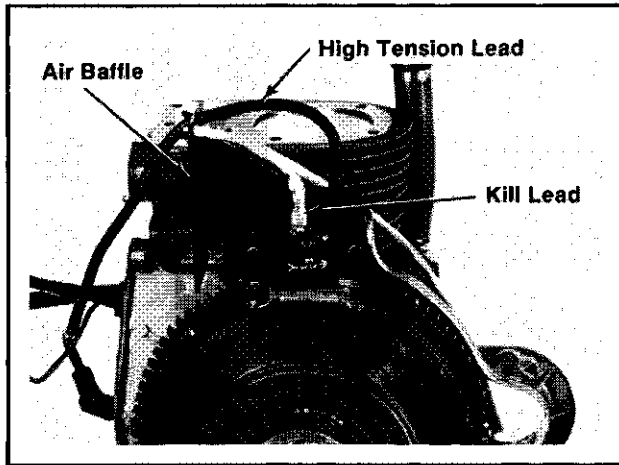

Figure 12A-27. Installing Air Baffle To Module.

INSTALL CYLINDER HEAD AND SPARK PLUG

1. Install the gasket, cylinder head, bracket, plain washers, and hex cap screws. Refer to Figure 12A-28.

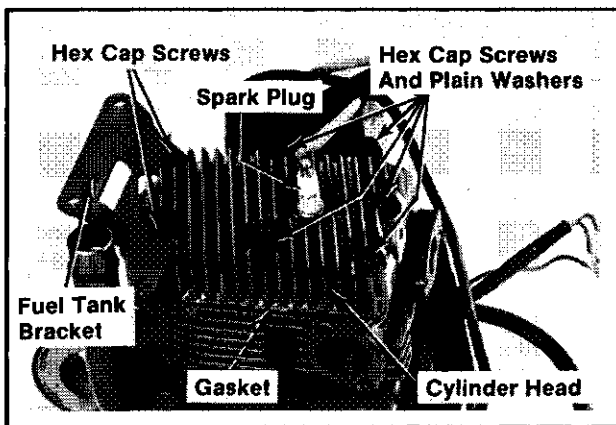

Figure 12A-28. Installing Cylinder Head And Spark Plug.

2. Torque the hex cap screws (in increments) in the sequence shown in Figure 12A-29 to 15/20 ft. lb.

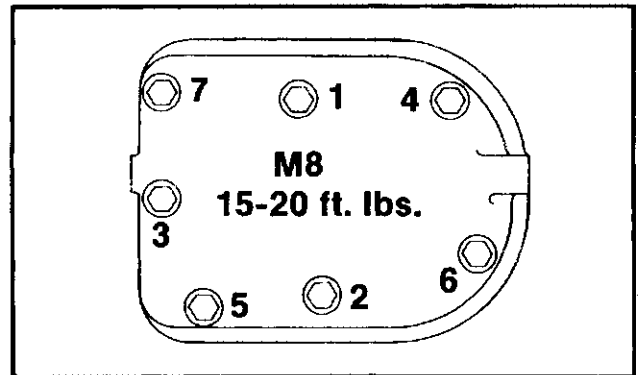

Figure 12A-29. Cylinder Head Fastener Torque Sequence.

3. Install the spark plug (.025" gap); torque to 18/22 ft. lb.

INSTALL BREATHER COMPONENTS

1. Install the stud, gasket, breather plate, gasket, and seal. Make sure the small hole in breather plate is at the bottom. Refer to Figure 12A-30.

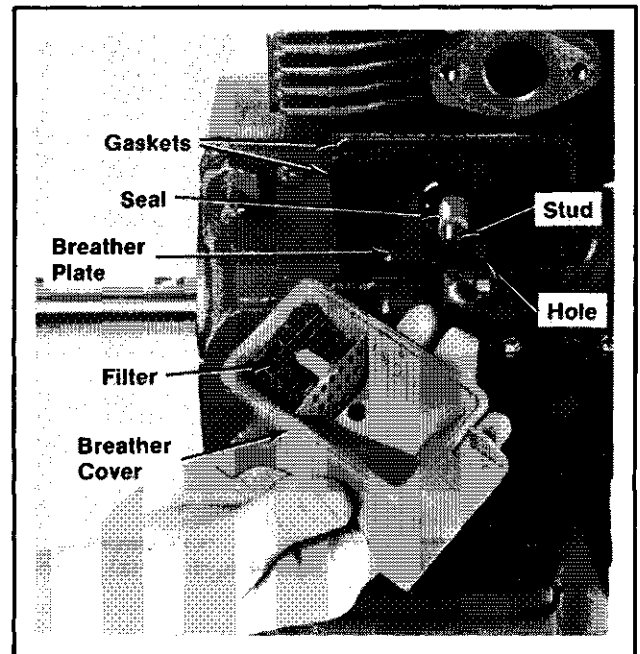

Figure 12A-30. Installing Breather Components.

2. Install the breather cover with filter, and palnut.

INSTALL SIDE AIR BAFFLES, BLOWER HOUSING, AND CYLINDER HEAD BAFFLE

1. Install the blower housing, keyswitch panel (if so equipped), and self-tapping screws. Refer to Figure 12A-31. Leave the screws slightly loose.

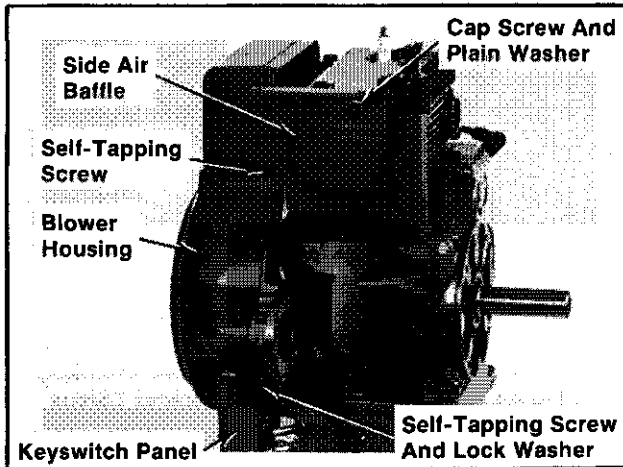

Figure 12A-31. Installing Blower Housing, Keyswitch Panel, And Side Air Baffle.

2. Install the side air baffle, self-tapping screw, plain washer, and hex cap screw. Leave the screws slightly loose.
3. Install the cylinder head baffle, plain washer, spark plug lead clip, hex cap sems screw, and self-tapping screw. Refer to Figure 12A-32. Leave the screws slightly loose.

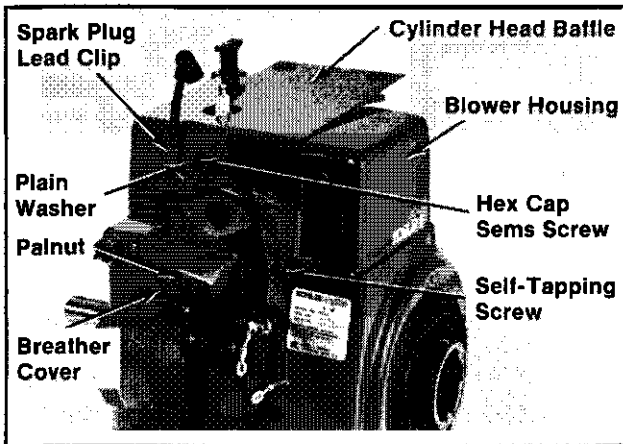

Figure 12A-32. Installing Blower Housing and Cylinder Head Baffle.

4. Tighten the screws securely when all pieces are in position.

INSTALL FUEL TANK AND BRACKETS

1. Install the bracket, split lock washers, and hex cap screws to crankcase. Refer to Figure 12A-33.

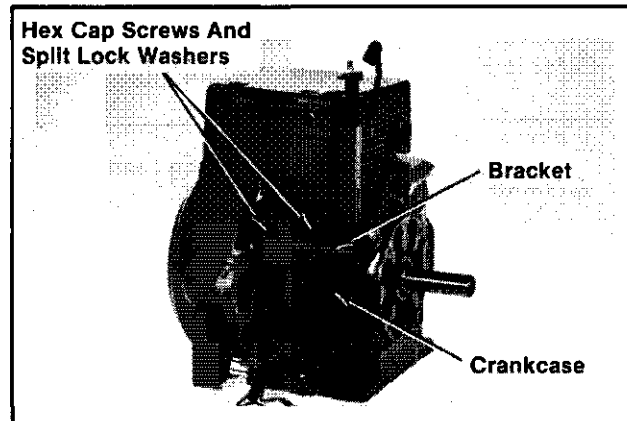

Figure 12A-33. Installing Fuel Tank Bracket To Crankcase.

2. Install the bracket, plain washers, and hex cap screws to fuel tank. Refer to Figure 12A-34. Torque the hex cap screws to **90 in. lb. maximum**.

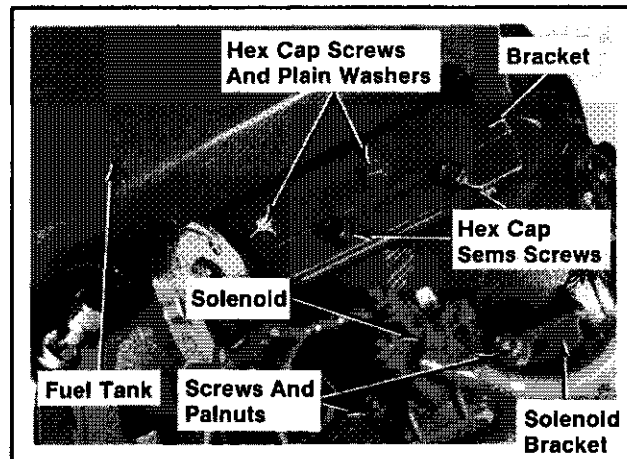

Figure 12A-34. Installing Fuel Tank And Solenoid.

3. Install the fuel tank with bracket, truss head screws, and hex cap sems screws. Refer to Figure 12A-35. Leave the screws loose until all pieces are in position.
 - a. Torque the truss head screws to **90 in.lb. maximum**.
 - b. Torque the hex cap sems screws to **70 in.lb. maximum**.

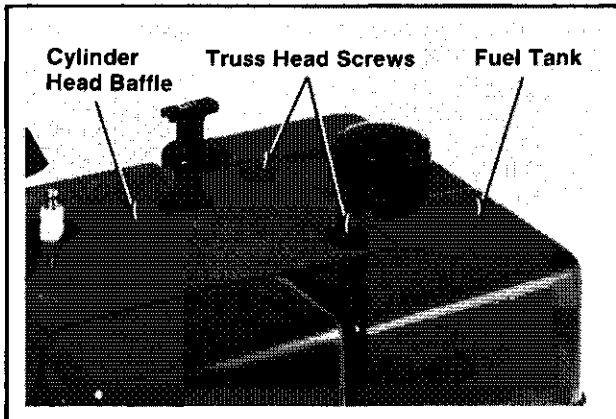

Figure 12A-35. Installing Fuel Tank.

4. Install the fuel filter and fuel line to tank outlet.

INSTALL SOLENOID AND ELECTRIC STARTER

1. Install the solenoid, screws, and palnuts to bracket. Install the leads to solenoid. Refer to Figure 12A-34.
2. Remove the 1/4-20 hex nuts and thru bolts from electric starter.

CAUTION: Be sure to hold the commutator end cap and drive end cap against the starter frame to prevent the starter from becoming disassembled. Refer to Figure 12A-36.

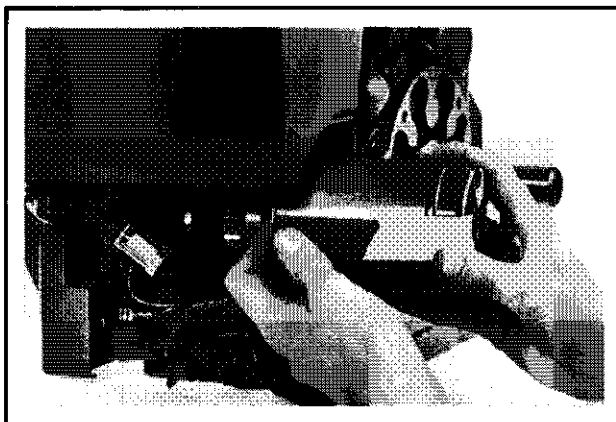

Figure 12A-36. Installing Starter.

3. Install the starter to bearing plate, and install the top thru bolt. Refer to Figure 12A-37. Leave the bolt slightly loose.

NOTE: Route fuel line and wiring harness behind starter.

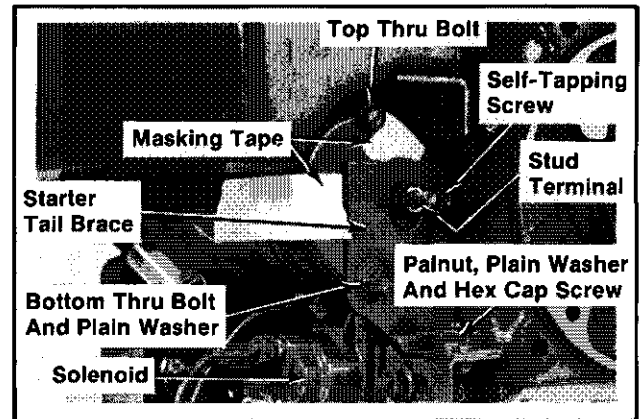

Figure 12A-37. Installing Starter And Starter Tail Brace.

4. Install the starter tail brace, self-tapping screws, plain washer, and bottom thru bolt. Install the hex cap screws, plain washer, and palnut. Leave the screws slightly loose.
5. Tighten the starter thru bolts and other hardware securely when all pieces are in position.

CAUTION: Make sure the electric starter stud terminal is centered in the slot in tail brace. Electric arcing may occur if terminal is not centered or it touches the tail brace.

INSTALL RETRACTABLE STARTER

1. Install the retractable starter and hex cap screws. Leave the screws slightly loose.
2. Pull the starter handle out 8-10" until pawls engage in the drive cup. Hold the handle in this position and tighten screws securely. Refer to Figure 12A-38.

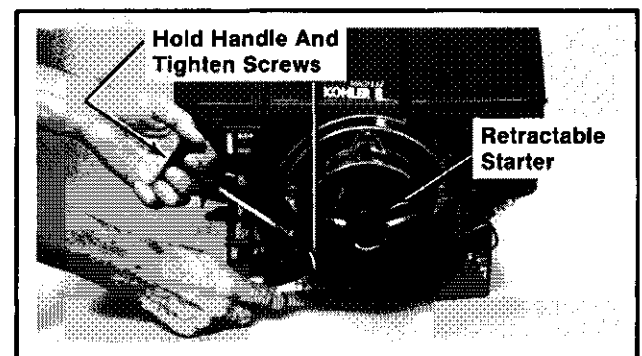

Figure 12A-38. Installing Retractable Starter.

INSTALL EXTERNAL GOVERNOR COMPONENTS, AND THROTTLE AND CHOKE CONTROLS

1. If the throttle and choke control lever assembly is equipped with a kill switch, install the kill lead from module to kill switch.
2. Install the throttle and choke control lever assembly to handle bracket and engine crankcase. Secure with the spacers, plain washers, hex cap screws, and hex cap sems screw. Refer to Figure 12A-39.

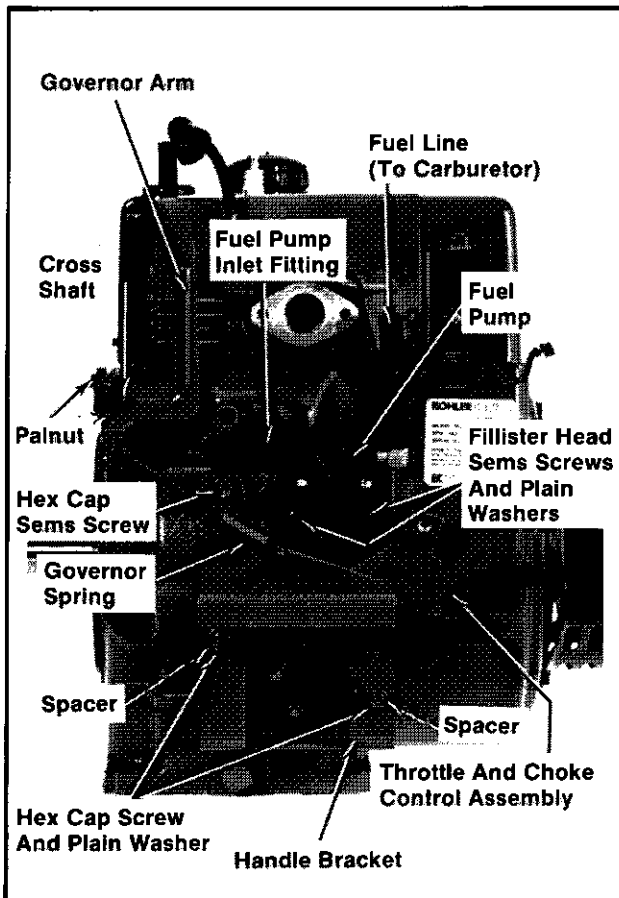

Figure 12A-39. Installing Throttle And Choke Controls, External Governor Components, And Fuel Pump.

3. Install the governor spring to throttle lever and governor arm. For proper engine operation, make sure the spring is installed in the correct position in governor arm.
4. Install the governor arm to cross shaft. Leave the palnut slightly loose as the governor arm and cross shaft will be adjusted after the carburetor and throttle linkage are installed.

INSTALL FUEL PUMP

1. Install the gasket, fuel pump, plain washers, and fillister head sems screws. Refer to Figures 12A-39 and 12A-40.

CAUTION: Make sure the fuel pump lever is positioned above the camshaft. Damage to the fuel pump, and subsequent severe engine damage could result if the lever is positioned below the camshaft.

Torque the screws to **40/45 in. lb.**

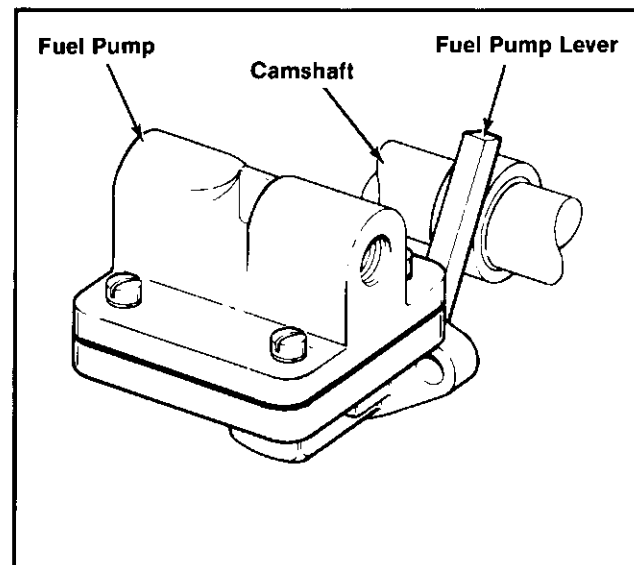

Figure 12A-40. Installing Fuel Pump.

2. Connect the fuel line (from tank) to fuel pump inlet fitting.

INSTALL CARBURETOR, THROTTLE LINKAGE, AND CHOKE LINKAGE

1. Install the fuel line and hose clamp. Refer to Figure 12A-41.

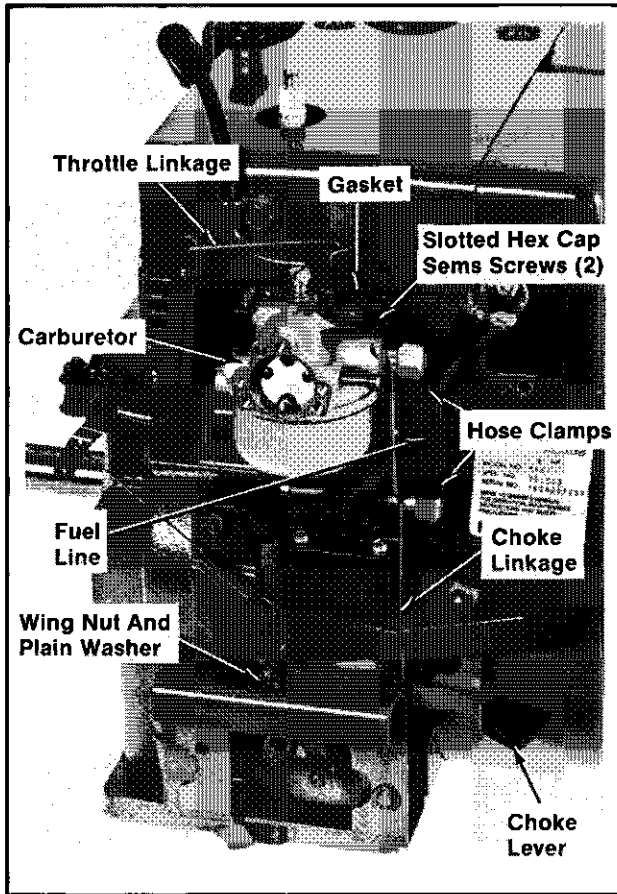

Figure 12A-41. Installing Carburetor, Throttle Linkage, And Choke Linkage.

2. Install the throttle linkage, gasket, carburetor, and slotted hex cap sems screws.
3. Remove the wing nut, plain washer, and choke control lever. Install choke linkage to choke control lever and carburetor choke lever. Reinstall choke control lever, plain washer, and wing nut."
4. Adjust the governor as instructed under "Governor Adjustment."

Governor Adjustment

The governor cross shaft/governor arm must be adjusted every time the governor arm is loosened or removed from cross shaft. Refer to Figure 12A-42.

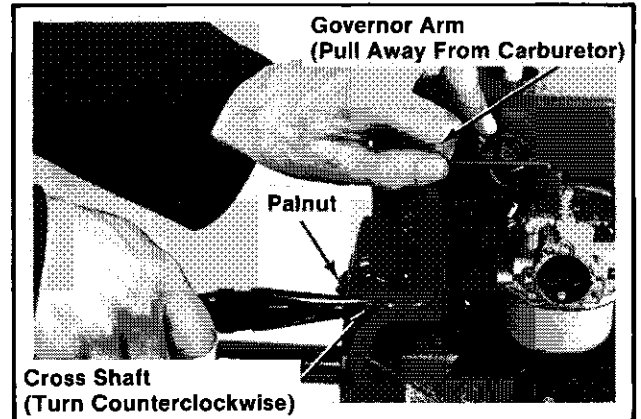

Figure 12A-42. Adjusting Governor Arm/Cross Shaft.

1. Pull the governor arm away from the carburetor as far as it will go.
2. Grasp end of cross shaft with pliers and turn counterclockwise as far as it will go.
3. Torque the palnut on governor arm to **15 in. lb.**

NOTE: Make sure there is at least $1/16$ " clearance between governor arm and bushing in crankcase to prevent interference. Refer to Figure 12A-43.

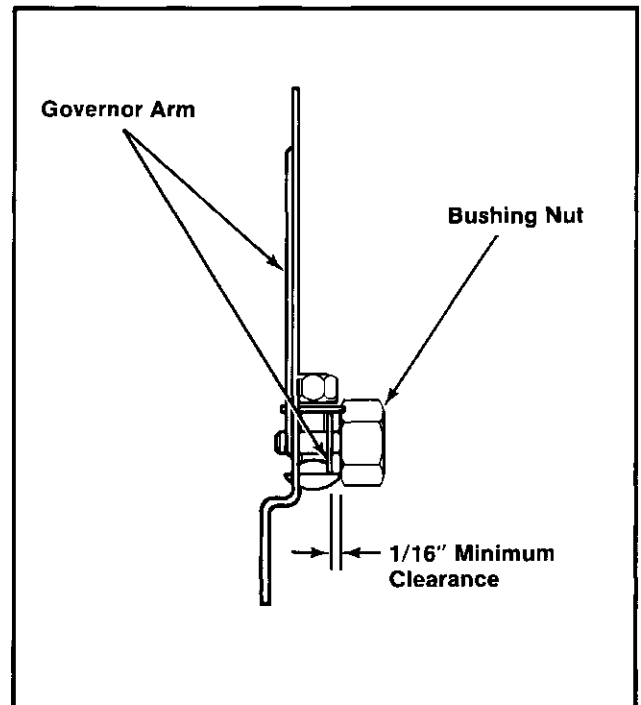

Figure 12A-43. Governor Arm/Bushing Clearance.

INSTALL RECTIFIER-REGULATOR

1. Insert B+ lead into center position of connector. Install the stator leads/connector to rectifier-regulator. Refer to Figure 12A-44.

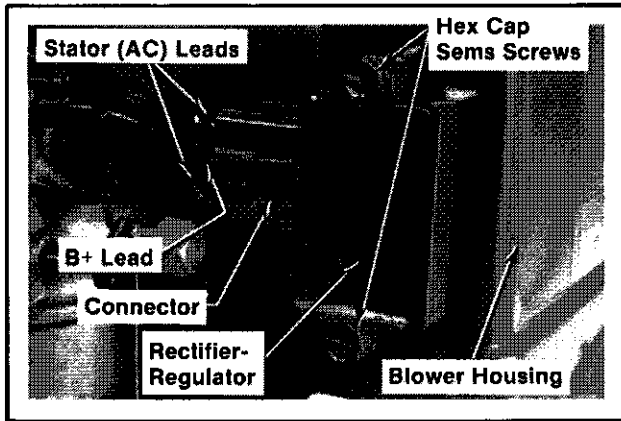

Figure 12A-44. Installing Rectifier-Regulator

2. Install the rectifier-regulator and hex cap sems screws.

INSTALL MUFFLER

1. Install the heat shield, gasket, muffler, and hex cap screws. Refer to Figure 12A-45.

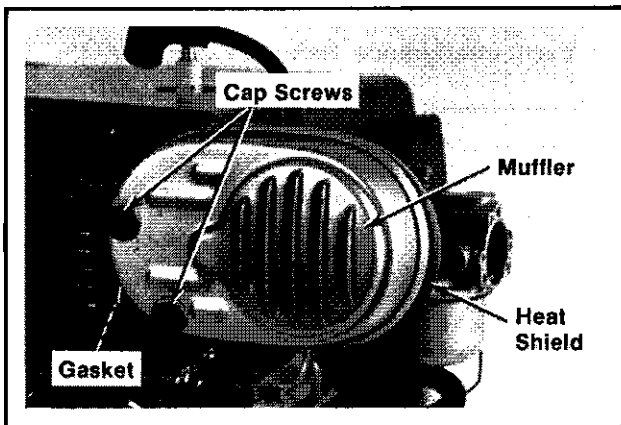

Figure 12A-45. Installing Muffler.

INSTALL AIR CLEANER

1. Install the breather hose, gasket, air cleaner base, and screws. Refer to Figure 12A-46.

CAUTION: Make sure the breather hose seals tightly in air cleaner base and breather cover to prevent unfiltered air from entering engine.

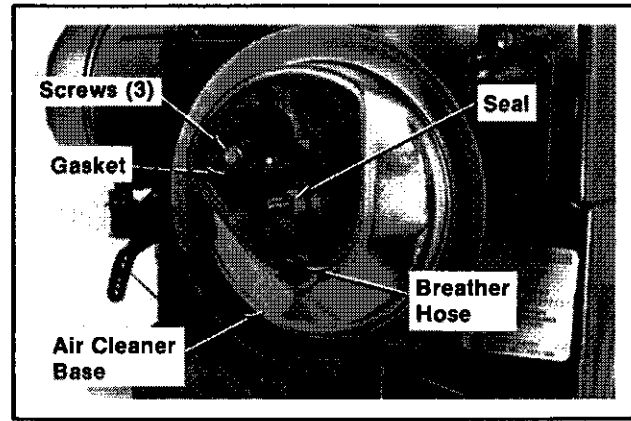

Figure 12A-46. Installing Air Cleaner Base.

2. Install the seal, paper element, element cover, and element cover nut. Tighten nut to **50 in. lbs.** torque. Refer to Figure 12A-47.

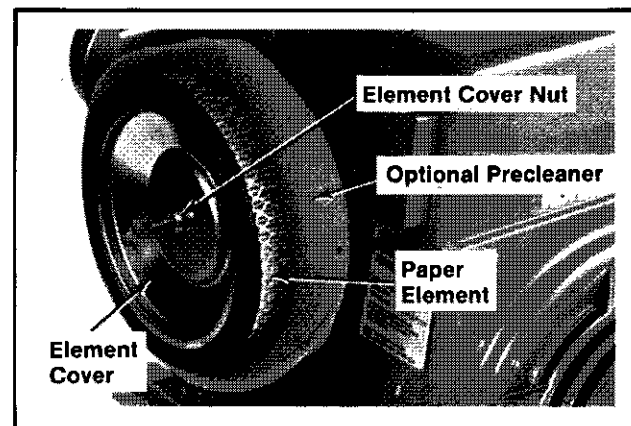

Figure 12A-47. Installing Air Cleaner Element.

3. If so equipped, install the foam precleaner (cleaned and oiled) over paper element.
4. Install air cleaner cover and wing nut. Tighten wing nut until it is snug. Do not overtighten. Refer to Figure 12A-48.

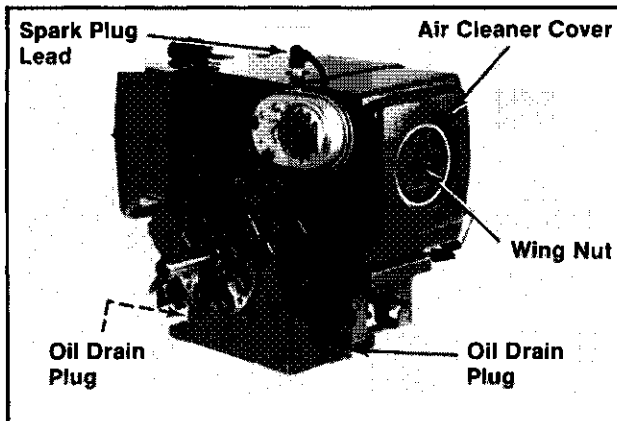

Figure 12A-48. Installing Air Cleaner Cover, Oil Drain, And Spark Plug Lead.

PREPARE THE ENGINE FOR OPERATION

The engine is now completely reassembled. Before operating the engine, be sure to do the following:

- Make sure all hardware is tightened securely and oil drain plugs are installed.
- Fill the crankcase with the correct amount, weight, and type of oil. Refer to the oil recommendations and procedures in the "General Information" and "Periodic Maintenance" sections.
- Fill the fuel tank with the proper type of gasoline and open fuel shut-off valve (if equipped). Refer to the fuel recommendations in the "General Information" section.
- Adjust the carburetor main fuel needle, idle fuel needle, or idle speed adjusting screw as necessary. Refer to the "Fuel System And Governor" section.
- Make sure the maximum engine speed does not exceed 3600 RPM. Adjust the high speed stop as necessary. Refer to the "Fuel System And Governor" section.

SECTION 12B

MAGNUM

Single Cylinder Engine
Service Manual

Models M8, M10, M12
M14, M16

TP-2203-A 3/86

KOHLER
engines

MODELS M10, M12, M14, M16 REASSEMBLY

The following sequence is suggested for complete engine reassembly. This procedure assumes that all components are new or have been reconditioned, and all component subassembly work has been completed. This procedure may have to be varied slightly to accommodate options or special equipment.

CAUTION: Make sure the engine is assembled using all specified torque values, tightening sequences, and clearances. Failure to observe specifications could cause severe engine wear or damage.

Always use new gaskets.

1. Install rear bearing.
2. Install governor gear and cross shaft.
3. Install tappets and camshaft.
4. Install balance gears.
5. Install crankshaft.
6. Install front bearing.
7. Install fuel line and wiring harness.
8. Install bearing plate.
9. Install oil seals.
10. Install piston rings.
11. Install piston to connecting rod.
12. Install piston/connecting rod.
13. Install oil pan.
14. Install valves.
15. Install stator.
16. Install fan, flywheel, grass screen, and drive cup or rope start pulley.
17. Install ignition module and air baffle.
18. Install cylinder head and spark plug.
19. Install side air baffles, blower housing, and cylinder head baffle.
20. Install electric starter.
21. Install fuel tank.
22. Install oil fill/dipstick tube.
23. Install retractable starter.

24. Install fuel pump.
25. Install breather.
26. Install external governor components, and throttle and choke controls.
27. Install carburetor, throttle linkage, and choke linkage.
28. Install rectifier-regulator.
29. Install muffler.
30. Install air cleaner.

INSTALL REAR BEARING

1. Install the rear bearing into crankcase using the #4747 handle and appropriate bearing installer. (Refer to the "Special Tools" section). Make sure the bearing is bottomed fully, and is straight and true in bore. Refer to Figure 12B-1.

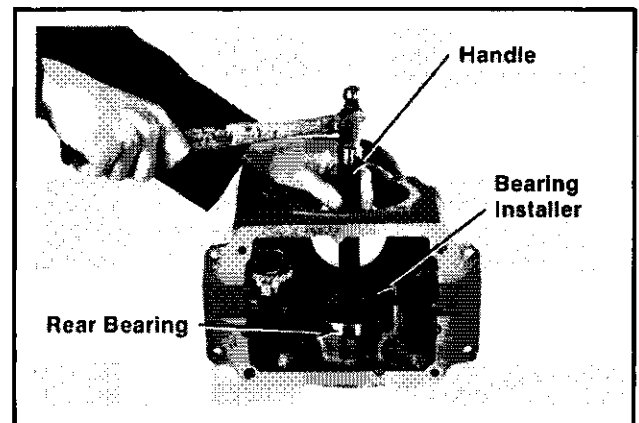

Figure 12B-1. Installing Rear Bearing.

INSTALL GOVERNOR GEAR AND CROSS SHAFT

1. Install the cross shaft, sleeve, and bushing nut. Torque bushing nut to **100/120 in. lb.** Refer to Figures 12B-2 and 12B-3.

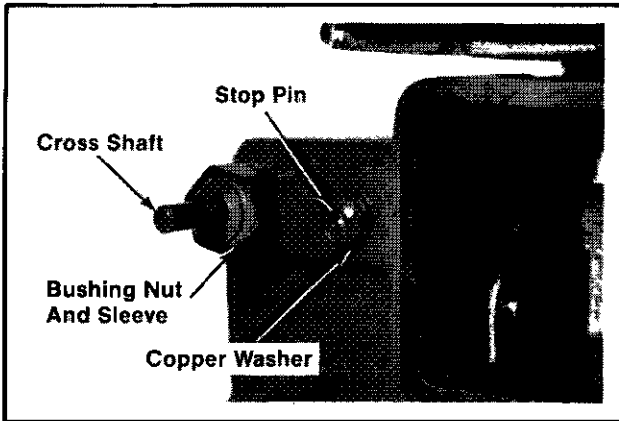

Figure 12B-2. Installing Governor Gear And Cross Shaft.

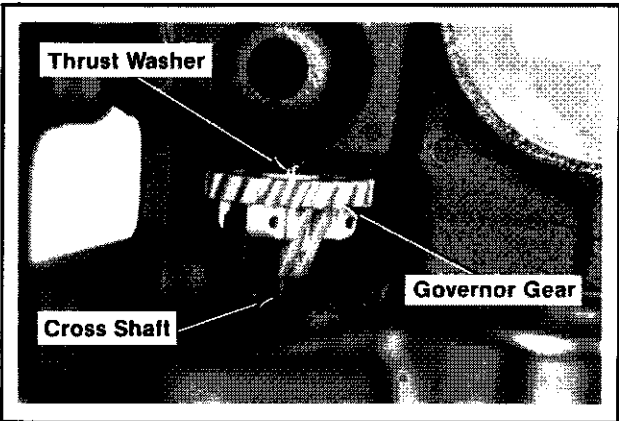

Figure 12B-3. Installing Governor Gear And Cross Shaft.

2. Install the thrust washer, governor gear, copper washer, and stop pin.

INSTALL TAPPETS AND CAMSHAFT

1. Install the intake valve tappet and exhaust valve tappet into crankcase. (Intake valve tappet towards bearing plate side; exhaust valve tappet towards PTO side of crankcase.) Refer to Figure 12B-4.

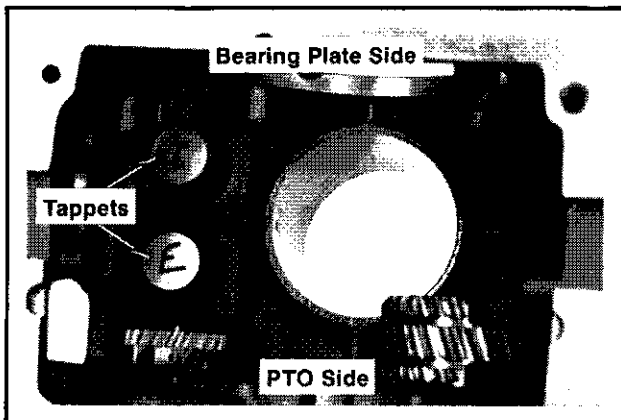

Figure 12B-4. Installing Tappets.

2. Install the camshaft, one .010" shim spacer, and the camshaft pin (from bearing plate side). Do not drive the camshaft pin into its final position at this time. Refer to Figure 12B-5.

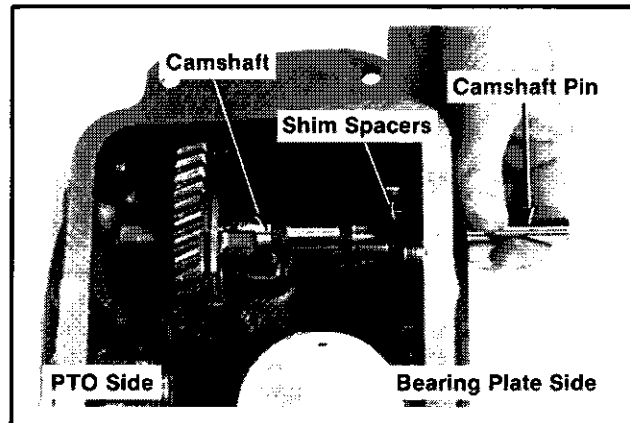

Figure 12B-5. Installing Camshaft.

3. Measure the camshaft end play between the spacer and crankcase boss using a flat feeler gauge. Refer to Figure 12B-6.

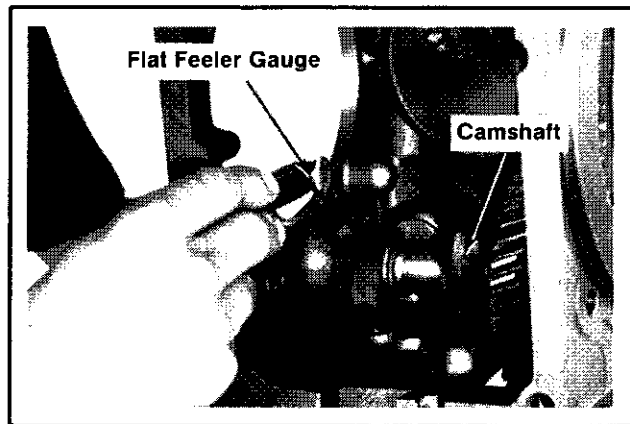

Figure 12B-6. Measuring Camshaft End Play.

Recommended camshaft end play is $.005"/.010"$. Add or subtract $.005"$ and/or $.010"$ shim spacers as necessary to obtain the proper end play.

4. Drive the camshaft pin into the PTO side of crankcase until it is $.300"/.330"$ from machined bearing plate gasket surface. Refer to Figure 12B-7.

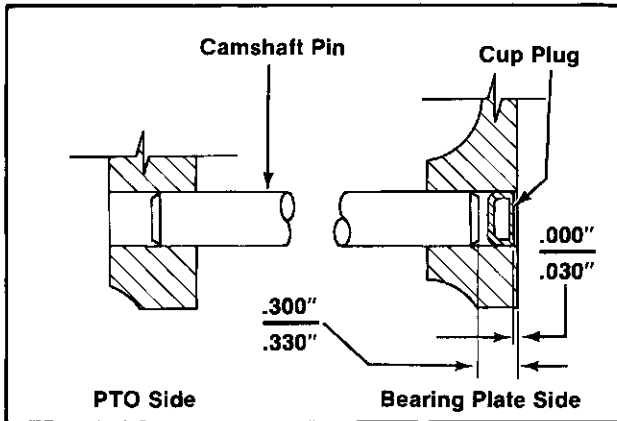

Figure 12B-7. Installing Camshaft Pin And Cup Plug.

5. Apply Loctite® #290 (or equivalent) to cup plug. Install the cup plug into bore in bearing plate mounting surface. Plug should be **FLUSH** to **.030"** below mounting surface. Refer to Figures 12B-7 and 12B-8.

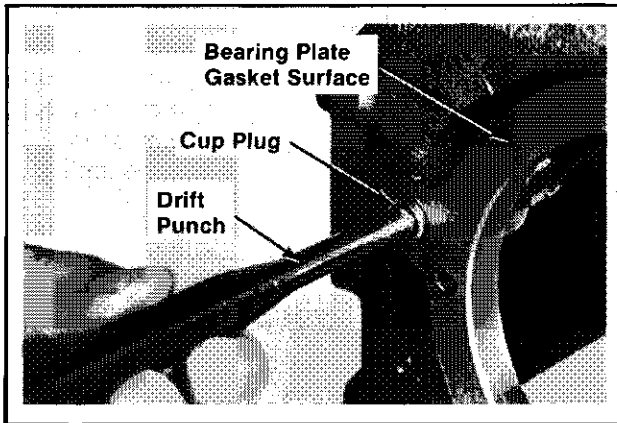

Figure 12B-8. Installing Cup Plug.

INSTALL BALANCE GEARS On Engines So Equipped

NOTE: The balance gears must be timed to the crankshaft whenever the crankshaft is installed. Use a balance gear timing tool to simplify this procedure (refer to the "Special Tools" section in this manual). If the balance gears must be timed without using the tool, do not install the lower balance gear (closest to oil pan) until **after** the crankshaft has been installed.

Refer to "INSTALL CRANKSHAFT" for specific timing procedures.

1. Install the 3/8" spacer, one .010" shim spacer, balance gear, one .020" shim spacer, and retaining ring (rounded edge towards balance gear). Refer to Figure 12B-9.

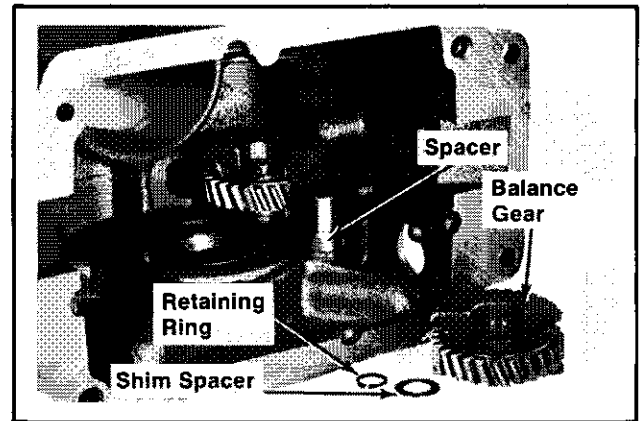

Figure 12B-9. Installing Balance Gears.

2. Check end play with a flat feeler gauge. Refer to Figure 12B-10.

Recommended end play is **.002"/.010"**. If end play is not within range, install or remove .005" and .010" spacers*, as necessary.

*Balance gear spacer kit, Kohler Part 47 755 01, contains enough 3/8", .005", .010", and .020" spacers to obtain correct end play for both balance gears.

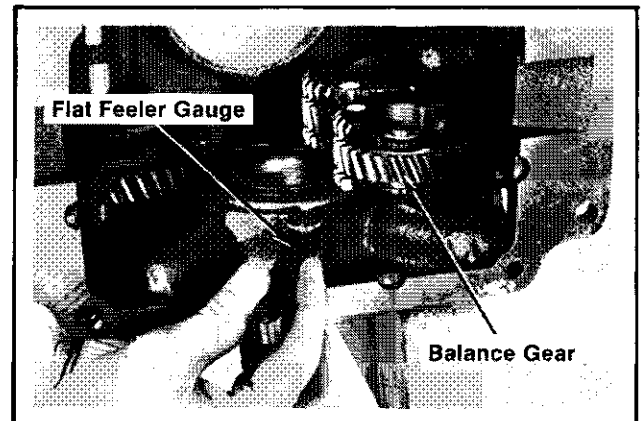

Figure 12B-10. Measuring Balance Gear End Play.

INSTALL CRANKSHAFT On Engines Without Balance Gears

1. Lubricate the crankshaft rear bearing surface. Insert the crankshaft through the rear bearing.

NOTE: If the crankshaft and bearing plate have not been separated, position the fuel line and wiring harness between the bearing plate and crankcase before pressing the crankshaft all the way in.

- Align the primary timing mark on crankshaft with the timing mark on camshaft. Refer to Figure 12B-11. Press the crankshaft into rear bearing. Make sure the camshaft and crankshaft gears mesh and that the timing marks remain aligned while pressing.

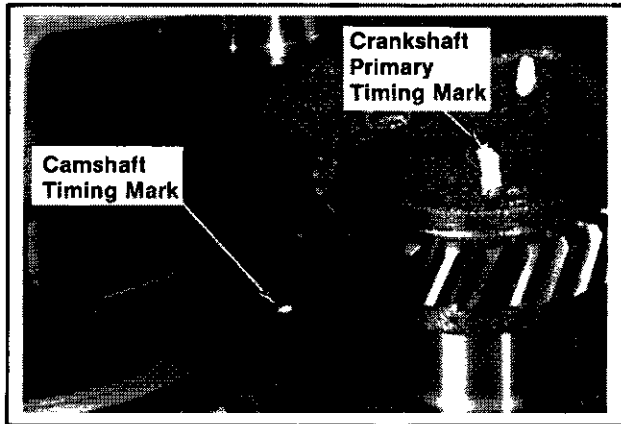

Figure 12B-11. Aligning Crankshaft And Camshaft Timing Marks.

On Engines With Balance Gears

METHOD 1—WITH BALANCE GEAR TIMING TOOL

- Align the primary timing marks of balance gears with the teeth on timing tool. Insert tool so it meshes with gears. Hold or clamp tool against oil pan gasket surface. Refer to Figure 12B-12.

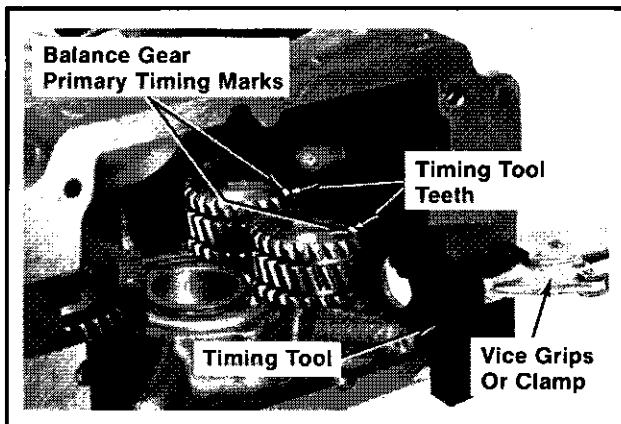

Figure 12B-12. Installing Balance Gear Timing Tool.

- Lubricate the crankshaft rear bearing surface. Insert the PTO end of crankshaft through rear bearing. "Straddle" the primary and secondary timing marks on crankshaft over the rear bearing oil drain (refer to Figure 12B-13). Press the crankshaft into rear bearing until the crankgear is just above the camshaft gear but not in mesh with it.

NOTE: If the crankshaft and bearing plate have not been separated, position the fuel line and wiring harness between the bearing plate and crankcase before pressing the crankshaft all the way in.

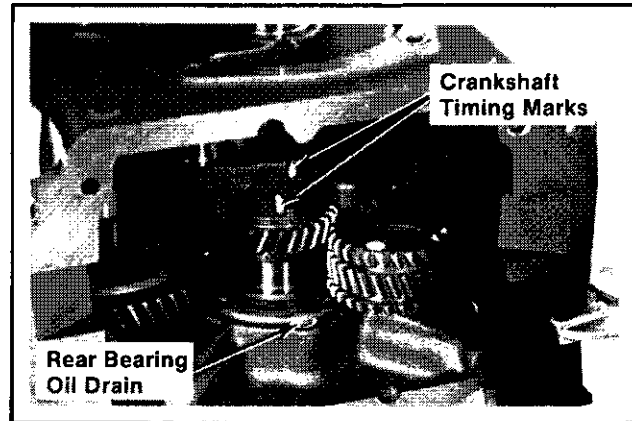

Figure 12B-13. Aligning Crankshaft And Balance Gears.

- Remove the balance gear timing tool and align the primary timing mark on the crankshaft with the timing mark on the camshaft gear. Refer to Figure 12B-14. Press the crankshaft all the way into the rear bearing. Make sure the camshaft and crankshaft gears mesh and that the timing marks align while pressing.

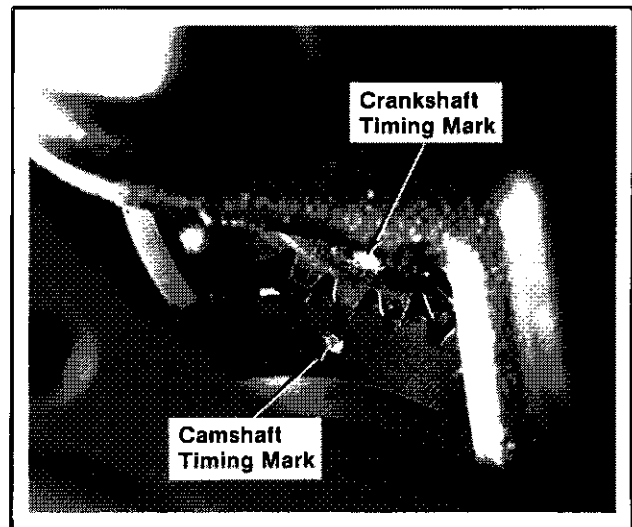

Figure 12B-14. Aligning Crankshaft And Camshaft Timing Marks.

- Check the timing of the crankshaft, camshaft, and balance gears:
 - The primary timing mark on crankshaft should align with the secondary timing mark on lower balance gear. Refer to Figure 12B-15.

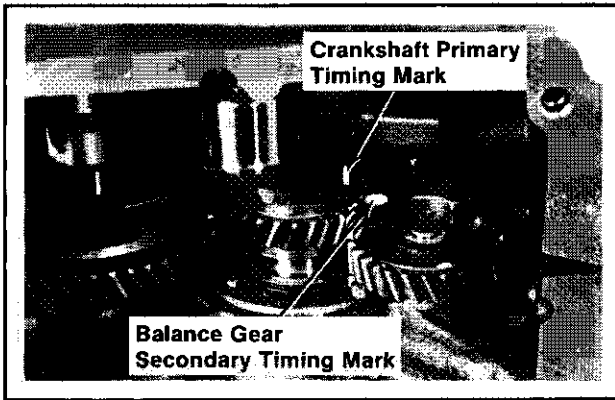

Figure 12B-15. Checking Crankshaft And Balance Gear Alignment.

- The primary timing mark on crankshaft should align with the timing mark on camshaft. Refer to Figure 12B-14.

If the marks do not align, the timing is incorrect and must be corrected.

METHOD 2—WITHOUT BALANCE GEAR TIMING TOOL

NOTE: The lower balance gear should be installed **after** the crankshaft has been installed.

1. Lubricate the crankshaft rear bearing surface. Insert the PTO end of crankshaft through rear bearing. Align the primary timing mark on crankshaft with the primary timing mark on upper balance gear. Refer to Figure 12B-16. Press the crankshaft into rear bearing until the crankgear just starts to mesh (about 1/16") with the center ring of balance gear teeth.

NOTE: If the crankshaft and bearing plate have not been separated, position the fuel line and wiring harness between the bearing plate and crankcase before pressing the crankshaft all the way in.

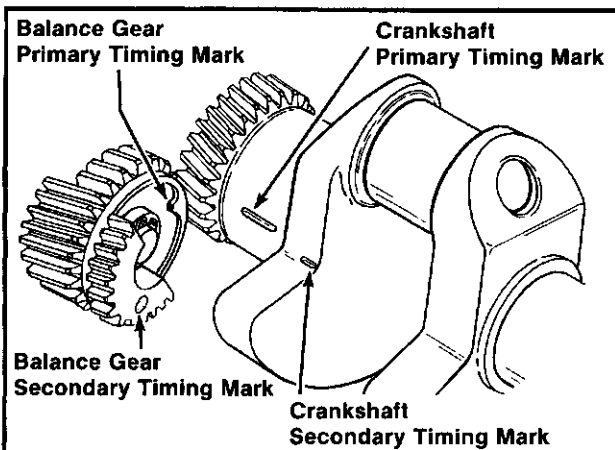

Figure 12B-16. Timing Marks On Balance Gear And Crankshaft.

2. Align the primary timing mark on the crankshaft with the timing mark on the camshaft gear. Refer to Figure 12B-14. Press the crankshaft all the way into the rear bearing. Make sure the camshaft and crankshaft gears mesh and that the timing marks align while pressing.
3. Position the crankshaft so it is about 15° past BDC. Install 3/8" spacer, and one .010" shim spacer. Align the secondary timing mark on the lower balance gear with the secondary timing mark on the crankshaft. Install the lower balance gear on the stub shaft. If properly timed, the primary timing mark on the crankshaft will now be aligned with the secondary timing mark on the lower balance gear. Refer to Figures 12B-9 and 12B-16.
4. Install one (1) .020" shim spacer and retaining ring (rounded edge towards gear). Check end play of lower balance gear as instructed under "INSTALL BALANCE GEARS." Refer to Figures 12B-9 and 12B-10.
5. Check the timing of the crankshaft, camshaft, and balance gears:
 - The primary mark on crankshaft should align with the primary timing mark on upper balance gear. Refer to Figure 12B-16.
 - The primary mark on crankshaft should align with the secondary timing mark on lower balance gear. Refer to Figure 12B-15.
 - The primary mark on crankshaft should align with the timing mark on camshaft. Refer to Figure 12B-14.

If the marks do not align, the timing is incorrect and must be corrected.

INSTALL FRONT BEARING

1. Install the front bearing into the bearing plate using the #4747 handle and appropriate bearing installer. (Refer to the "Special Tools" Section). Make sure the bearing is bottomed fully, and straight and true in the bore.

INSTALL FUEL LINE AND WIRING HARNESS

1. Position the fuel line and wiring harness (if so equipped) to crankcase.
2. Adjust the fuel line and wiring harness to their final positions just before securing the bearing plate to the crankcase.

INSTALL BEARING PLATE

1. Install 3/18-16 studs into two of the bearing plate mounting holes. The studs ease locating and assembly of shims, gasket, and bearing plate. Refer to Figure 12B-17.

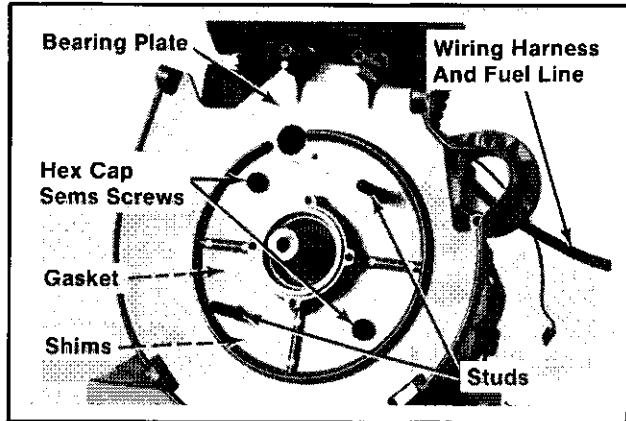

Figure 12B-17. Installing Wiring Harness And Bearing Plate.

2. Lubricate the bearing surface of crankshaft and bearing. Install the gasket, two or three .005" shims (as required)*, and bearing plate over studs.

*NOTE: Crankshaft end play is determined by the thickness of the gasket and shims between crankcase and bearing plate. Check the end play after the bearing plate is installed.

3. Install two hex cap sems screws and hand tighten. Remove the locating studs, and install the remaining two hex cap sems screws and hand tighten.
4. Position the wiring harness and fuel line in their final positions as marked during disassembly.
5. Tighten the screws evenly, drawing bearing plate to crankcase. Torque screws to **35 ft. lb.**
6. Check crankshaft end play between the inner bearing race and shoulder of crankshaft using a flat feeler gauge. Recommended total end play is **.003"/.020"**. Refer to Figure 12B-18.

If measured end play is not within limits, remove the bearing plate and, remove or install shims as necessary.

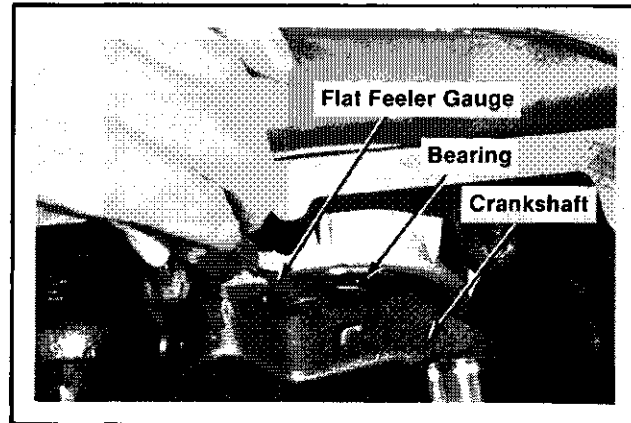

Figure 12B-18. Measuring Crankshaft End Play.

INSTALL OIL SEALS

1. Slide the appropriate seal sleeves over the crankshaft (refer to the "Special Tools" Section). Generously lubricate the lips of the oil seals with light grease. Slide the oil seals over the sleeves. Refer to Figure 12B-19.

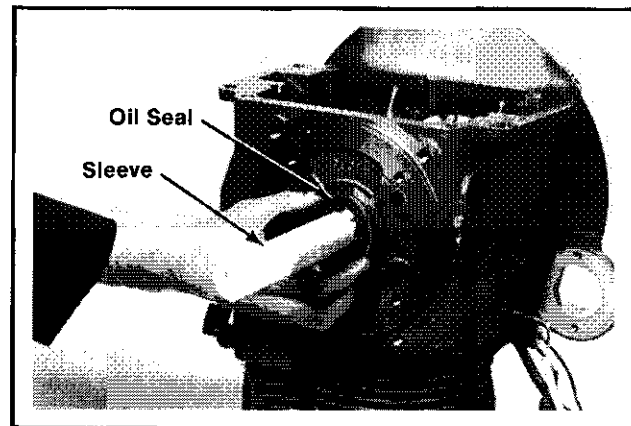

Figure 12B-19. Installing Oil Seals Using Sleeve.

2. Use the #11795 handle and appropriate seal drivers (refer to Figure 12B-20) to install the oil seals to the following depths:

Front Oil Seal (Bearing Plate)—1/32"
Rear Oil Seal (Crankcase PTO End)—1/8"
Tolerance on seal position—+3/64"; -1/64"

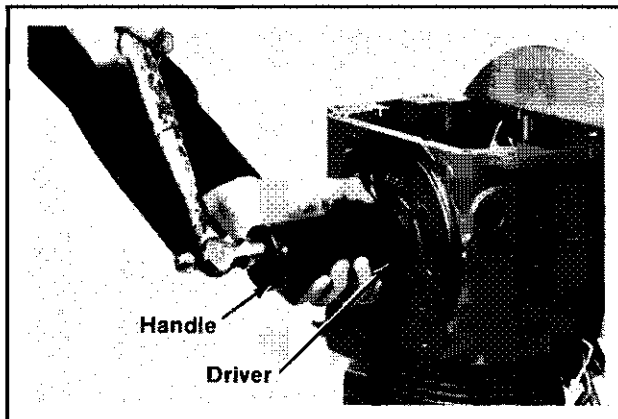

Figure 12B-20. Installing Oil Seals Using Driver.

INSTALL PISTON RINGS

NOTE: For detailed piston inspection and piston ring installation procedures, refer to the "Inspection And Repair/Reconditioning" section.

INSTALL PISTON TO CONNECTING ROD

"Style A" Piston

1. Install wrist pin and retainers.

"Style C" Piston

CAUTION: Proper orientation of the piston to the connecting rod is extremely important. Improper orientation may cause extensive wear or damage.

1. Orient piston and connecting rod so that the notch on piston and the match mark on connecting rod are facing the same direction.
2. Install wrist pin and retainers.

INSTALL PISTON/CONNECTING ROD

CAUTION: Proper orientation of the piston/ connecting rod inside engine is extremely important. Improper orientation may cause extensive wear or damage.

1. Stagger the piston rings in their grooves until end gaps are 120° apart.
2. Lubricate the piston and rings with engine oil. Install the piston ring compressor around piston. Refer to Figure 12B-21.

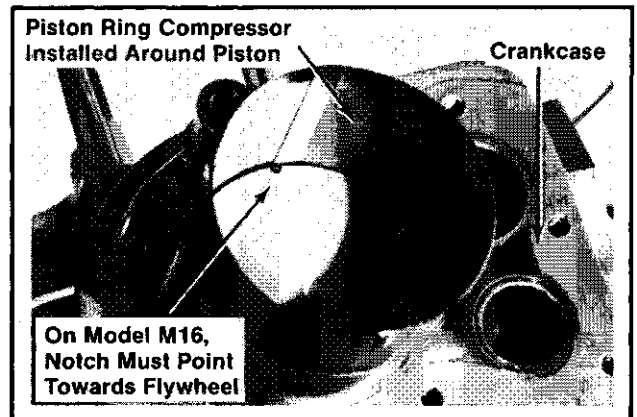

Figure 12B-21. Installing Piston.

3. Orient the notch (on "Style C" piston) and match marks on connecting rod towards the flywheel end of crankshaft. Gently push the piston/connecting rod into bore—do not pound on piston.
4. Lubricate the crankshaft and connecting rod journal surfaces with engine oil. Install the connecting rod cap—make sure the match marks are aligned and the oil hole is towards the camshaft. Refer to Figure 12B-22.

Install hex nuts and torque in increments as follows:

New Service Rod	Used/Reinstalled Rod
260 in. lb.	200 in. lb.

CAUTION: To prevent damage to connecting rod and engine, do not overtorque—loosen—and retorque the hex nuts on Posi-Lock connecting rods. Torque nuts, in increments, directly to the specified value.

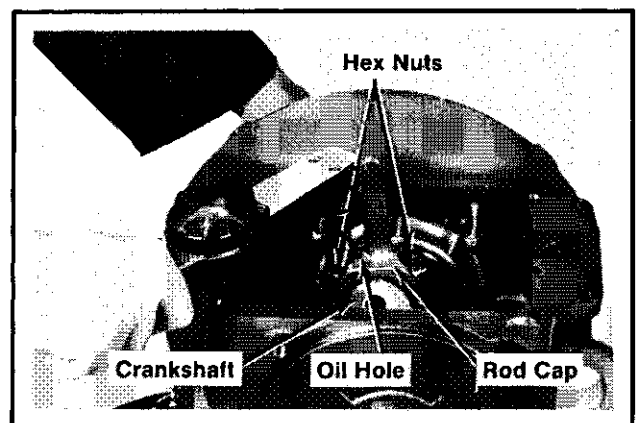

Figure 12B-22. Installing Connecting Rod Cap.

5. Rotate the crankshaft until the piston is at top dead center in bore to protect the dipper on the connecting rod.

INSTALL OIL PAN

1. Install the gasket, oil pan, and hex cap screws. Tighten screws securely.

INSTALL VALVES

1. Rotate the crankshaft until piston is at top dead center of compression stroke.
2. Install the valves and measure the valve-to-tappet clearance using a flat feeler gauge. Refer to Figure 12B-23.

NOTE: Valve faces and seats must be lapped-in before checking/adjusting valve clearance. Refer to the "Inspection And Repair/Reconditioning" section.

Valve-to-tappet cold clearance:

Intake Valve	Exhaust Valve
.008"/.010"	.017"/.019"

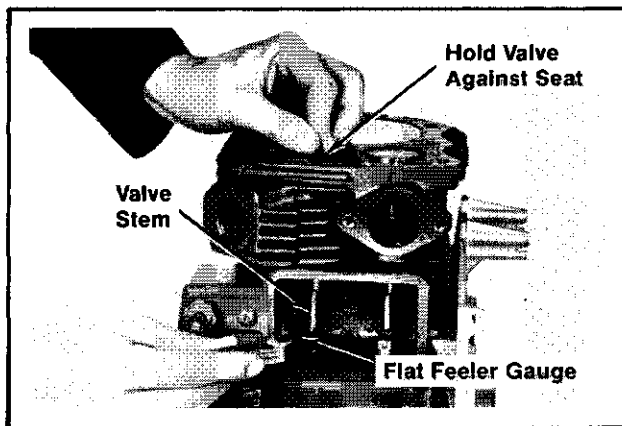

Figure 12B-23. Measuring Valve-To-Tappet Clearance.

3. Adjust valve-to-tappet clearance, as necessary.
Adjust valve-to-tappet clearance by turning the adjusting screw on tappets. Refer to Figure 12B-24.

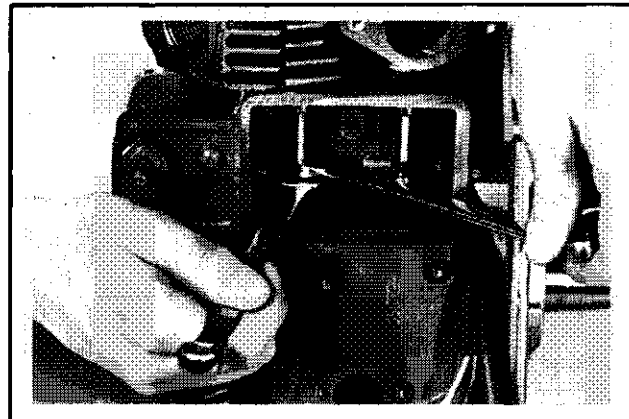

Figure 12B-24. Adjusting Valve-To-Tappet Clearance.

4. Install the valve spring upper retainers, valve springs (close coils to top), intake valve spring lower retainer, exhaust valve rotator, and valves. Refer to Figure 12B-25.

NOTE: Some models use a valve rotator on both valves.

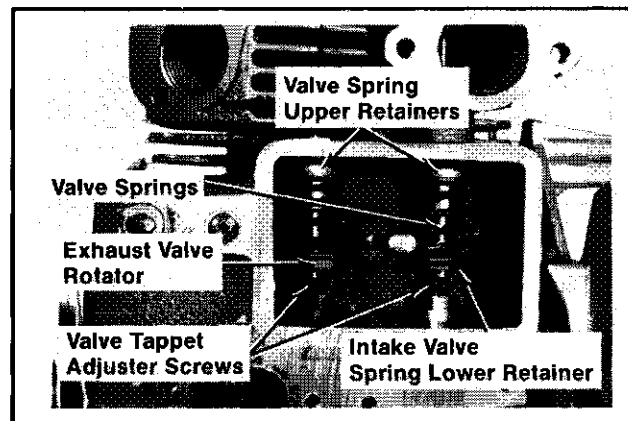

Figure 12B-25. Installing Valves.

5. Compress springs using a valve spring compressor and install keepers. Refer to Figure 12B-26.

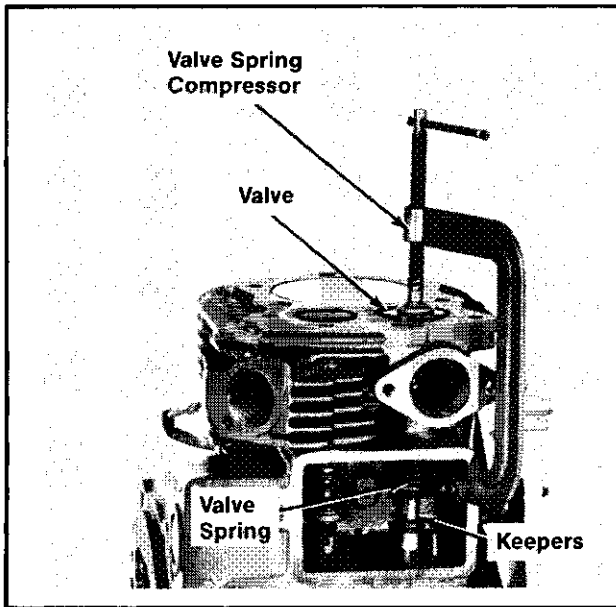

Figure 12B-26. Installing Valve Keepers.

INSTALL STATOR

1. Route the leads through the hole in bearing plate. Install stator and pan head screws. Install stator lead clip and self-tapping screw. Refer to Figure 12B-27.

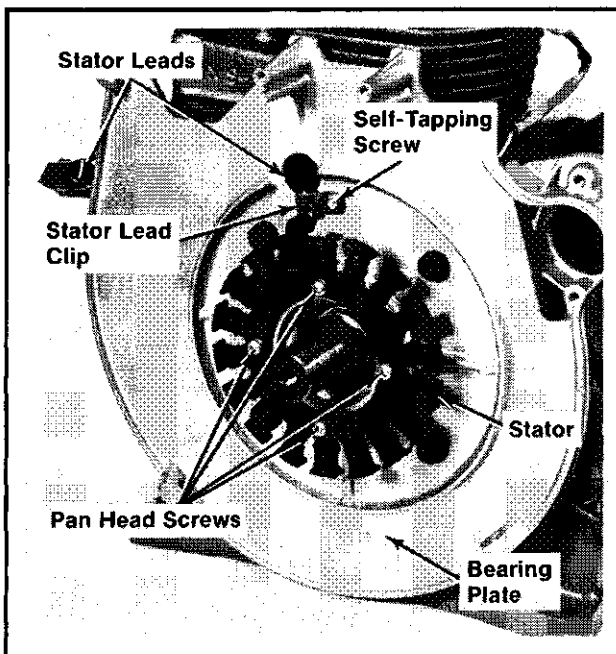

Figure 12B-27. Installing Stator.

2. Insert stator leads into outer positions of connector body.

INSTALL FAN, FLYWHEEL, GRASS SCREEN, AND DRIVE CUP OR ROPE START PULLEY

WARNING: *Damaging Crankshaft and Flywheel Could Cause Personal Injury!*



Using improper procedures to install the flywheel can crack or damage the crankshaft and/or flywheel. This not only causes extensive engine damage, but also is a serious threat to the safety of persons nearby, since broken fragments could be thrown from the engine. Always observe and use the following precautions and procedures when installing the flywheel:

- CAUTION:**
- A. Before installing the flywheel, make sure the crankshaft taper and flywheel hub are clean, dry, and completely free of lubricants. The presence of lubricants can cause the flywheel to be overstressed and damaged when the cap screw is torqued to specification.
 - B. Always use a flywheel strap wrench to hold flywheel when tightening flywheel fastener. Do not use any type of bar or wedge between the cooling fins or flywheel ring gear, as these parts could become cracked or damaged.

1. Install the spacers, fan and hex flange screws. Torque screws to **115 in. lb.** Refer to Figure 12B-28.

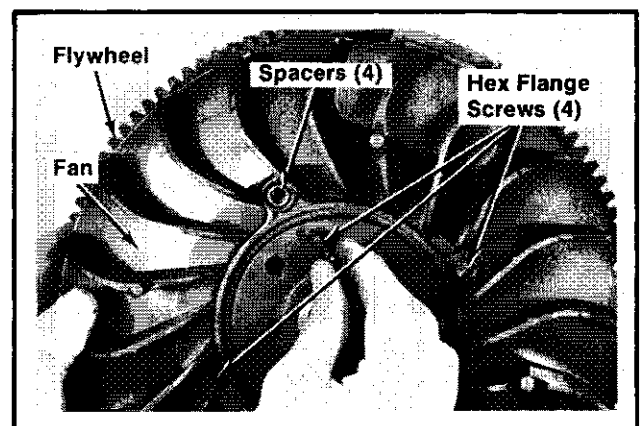

Figure 12B-28. Installing Fan To Flywheel.

- Place the flywheel on the crankshaft. Install the grass screen, and drive cup or rope start pulley as follows:

Rope Start

- Install the nylon grass screen to the fan. Refer to Figure 12B-29.

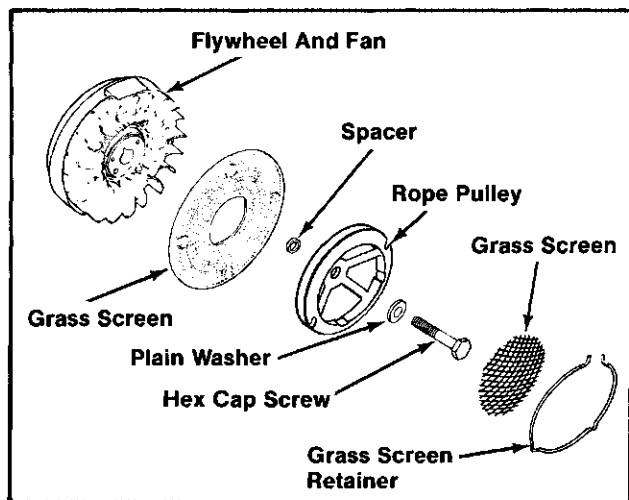

Figure 12B-29. Installing Flywheel, Rope Pulley, And Grass Screen—Rope Start Models.

- Install the spacer, rope pulley, plain washer, and hex cap screw (lubricate threads with oil). Hold the flywheel with a strap wrench and torque hex cap screw to **40/45 ft. lb.**
- Install the wire mesh grass screen and grass screen retainer to rope pulley.

Retractable Start

- Install the grass screen to the fan. Refer to Figure 12B-30.

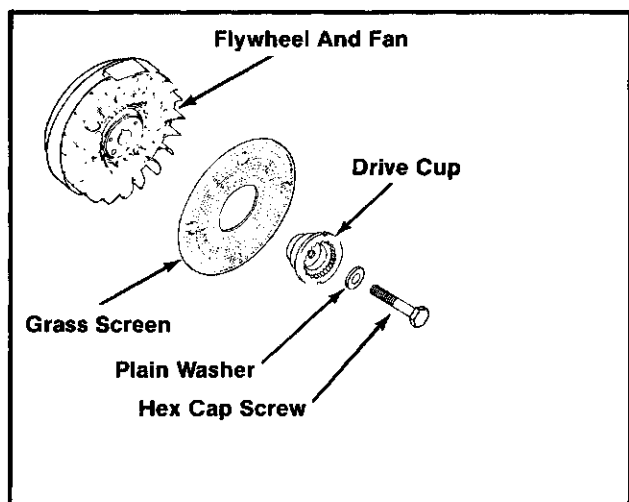

Figure 12B-30. Installing Flywheel, Grass Screen, And Drive Cup—Retractable Start Models.

- Install the drive cup, plain washer, and hex cap screw (lubricate threads with oil). Hold the flywheel with a strap wrench and torque hex cap screw to **40/45 ft. lb.**

Electric Start

- Refer to Figure 12B-31. Install the plain washer and hex cap screw (lubricate threads with oil). Hold the flywheel with a strap wrench and torque hex cap screw to **40/45 ft. lb.**

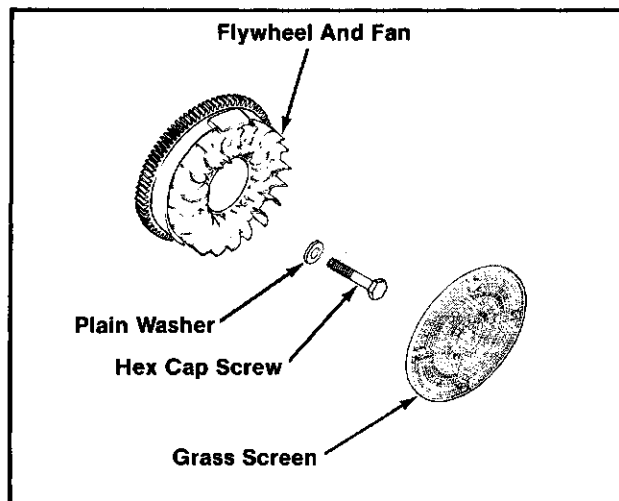

Figure 12B-31. Installing Flywheel And Grass Screen—Electric Start Models.

- Install the grass screen to the fan.

INSTALL IGNITION MODULE AND AIR BAFFLE

- Install the module, plain washers, and hex cap sems screws. Move the module as far from the flywheel/magnet as possible—tighten the hex cap screws slightly. Refer to Figure 12B-32.

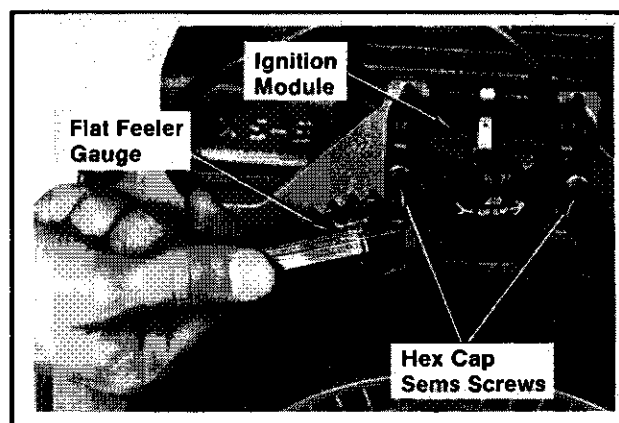

Figure 12B-32. Installing Ignition Module.

2. Insert a .018" flat feeler gauge or shim stock between magnet and module. Loosen hex cap screws so magnet pulls module down. Tighten hex cap screws to **32 in. lb.** Remove feeler gauge or shim stock. Due to the pull of the magnet the bearing plate will flex slightly. The magnet to module air gap should be within the final range of **.012"/.016"**.
3. Rotate the flywheel back and forth; check to make sure the magnet does not strike module. Check gap with a feeler gauge and readjust, if necessary. Refer to Figure 12B-33.

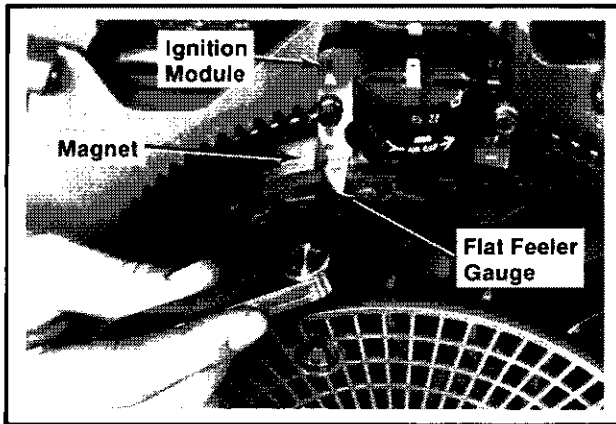

Figure 12B-33. Measuring Air Gap.

4. Install the air baffle over the module. Install the kill lead and spark plug lead into the slots in the baffle. Refer to Figure 12B-34.

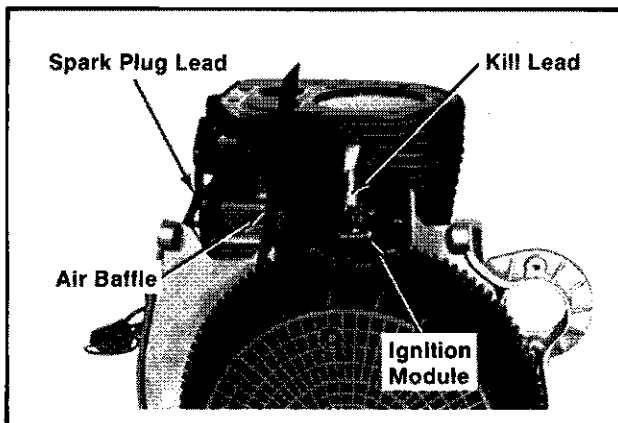

Figure 12B-34. Installing Air Baffle To Module.

INSTALL CYLINDER HEAD AND SPARK PLUG

1. Install the gasket, cylinder head, plain washers, hex spacer screw, lifting strap, and hex cap screws. Refer to Figure 12B-35.

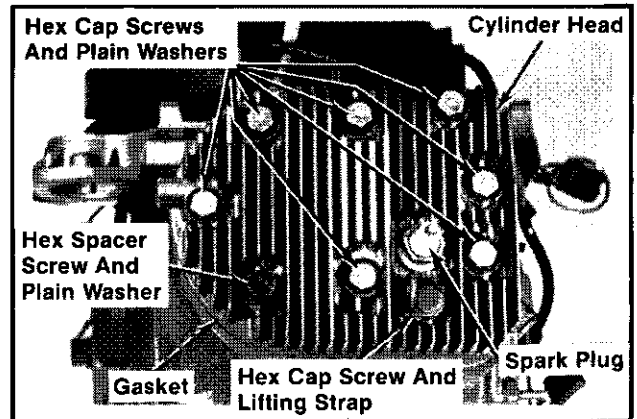

Figure 12B-35. Installing Cylinder Head And Spark Plug.

2. Torque the hex cap screws and hex spacer screw (in increments) in the sequence shown in Figure 12B-36, to **25/30 ft. lb.**

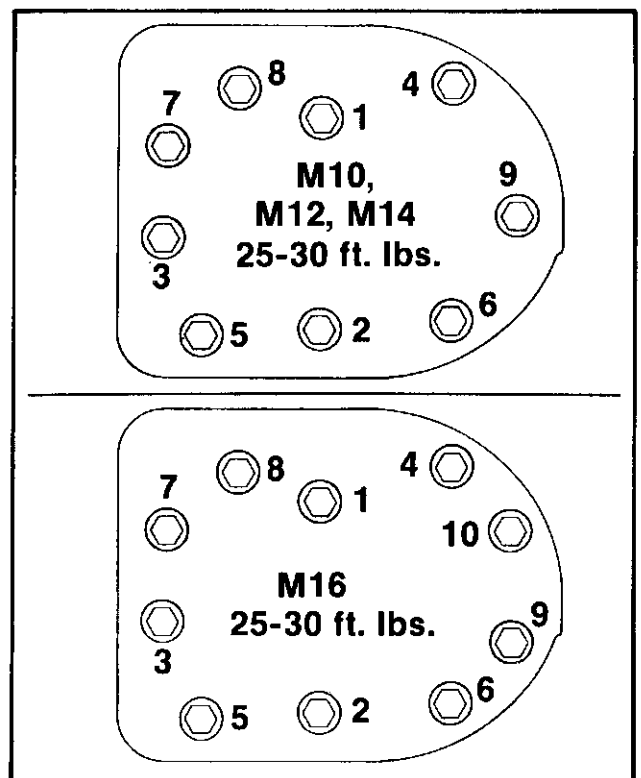

Figure 12B-36. Cylinder Head Fastener Torque Sequence.

3. Install the spark plug (.025" gap); torque it to **18/22 ft. lb.**

INSTALL SIDE AIR BAFFLES, BLOWER HOUSING, AND CYLINDER HEAD BAFFLE

1. Install the blower housing and two lower self-tapping screws. Refer to Figure 12B-37. Leave the screws loose.

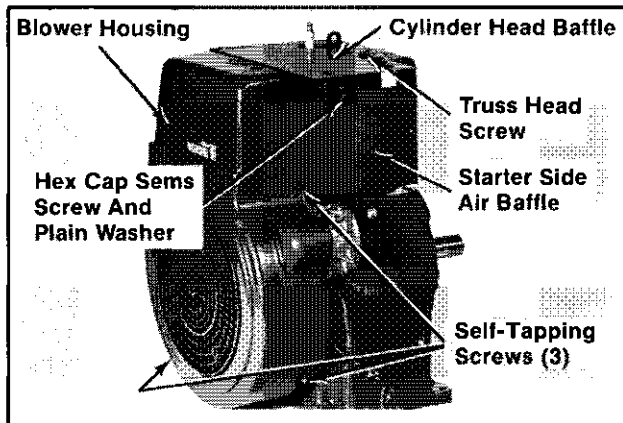

Figure 12B-37. Installing Blower Housing, Cylinder Head Baffle And Starter Side Air Baffle.

2. Install the cylinder head baffle and truss head screw. Leave the screw loose.
3. Install the starter side air baffle, plain washer, hex cap sems screw, and self-tapping screw. Leave the screws loose.
4. Install the carburetor side air baffle, spark plug lead clip, plain washer, and hex cap sems screw. Refer to Figure 12B-38. Leave the screw loose.

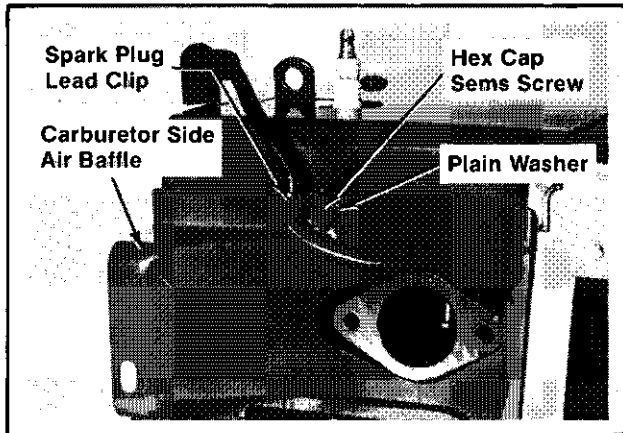

Figure 12B-38. Installing Carburetor Side Air Baffle.

5. Tighten the screws securely when all pieces are in position.

INSTALL ELECTRIC STARTER

1. Remove the 1/4-20 hex nuts and thru bolts from electric starter.

CAUTION: Be sure to hold the commutator end cap and drive end cap against the starter frame to prevent the starter from becoming disassembled. Refer to Figure 12B-39.

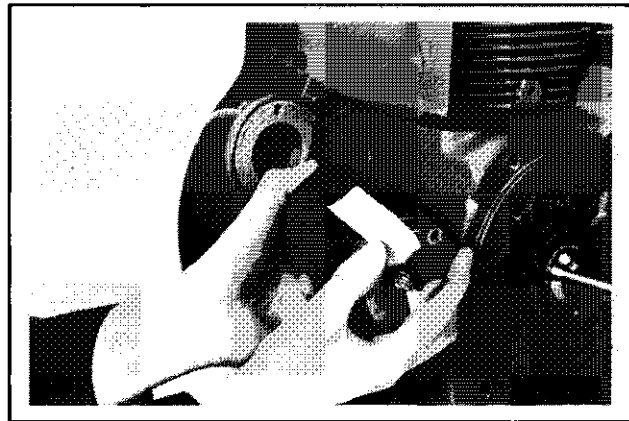

Figure 12B-39. Installing Starter.

2. Install the starter to bearing plate and install the thru bolts. Tighten bottom thru bolt hand tight, then tighten top thru bolt securely.

NOTE: Route fuel line and wiring harness behind starter.

3. Remove the bottom thru bolt after the top bolt has been tightened.

NOTE: Install the starter tail brace, bottom thru bolt, and starter solenoid after installing the fuel tank.

INSTALL FUEL TANK

1. If removed, install the isolation mounts to the fuel tank as follows:

Top of Tank: Install the threaded portion, 1/2" long, into the brass inserts in top of tank. Tighten isolation mounts **hand tight**.

Bottom of Tank: Install the threaded portion, 3/8" long, into the brass inserts in bottom of tank. Tighten isolation mounts **hand tight**.

2. Install bracket and palnuts to bottom isolation mounts. Tighten palnuts securely.
3. Insert the threaded portion of top isolation mounts through holes in cylinder head baffle. Install the plain washers and acorn nuts. Tighten the acorn nuts securely. Refer to Figure 12B-40.

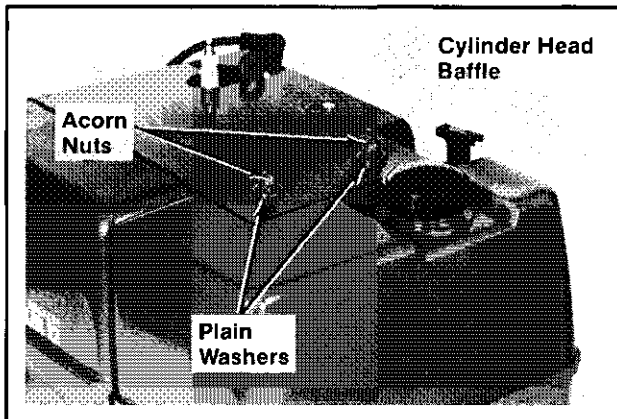

Figure 12B-40. Installing Fuel Tank.

4. Install the plain washers and hex cap sems screws through bracket and into crankcase. Leave the screws slightly loose. Refer to Figure 12B-41.

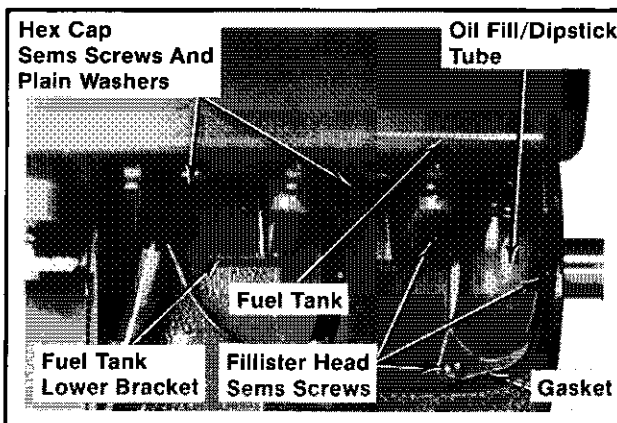

Figure 12B-41. Installing Tank And Oil Fill/Dipstick Tube.

5. Adjust the position of the fuel tank until the top of tank is even with top of blower housing. Tighten hex cap sems screws securely.
6. Install the fuel filter and fuel line to tank outlet. Refer to Figure 12B-42.

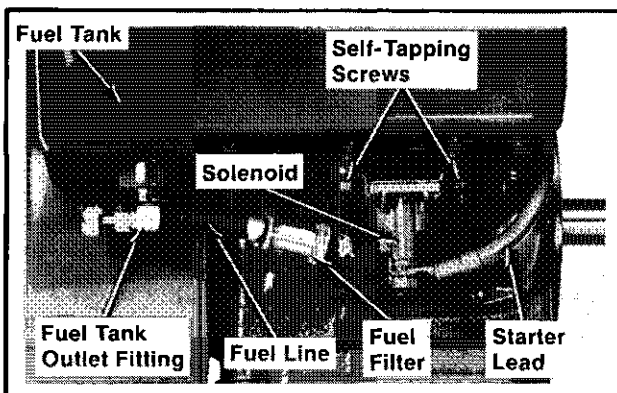

Figure 12B-42. Installing Fuel Tank And Solenoid.

7. Install the starter tail brace, bottom thru bolt, plain washer, and self-tapping screws. Tighten all screws securely when all pieces are in position.
8. Install the solenoid and self-tapping screws to fuel tank bracket. Install leads to solenoid and starter. Refer to Figure 12B-42.

INSTALL OIL FILL/DIPSTICK TUBE

1. Install the gasket, oil fill/dipstick tube, fillister head sems screws, and dipstick. Refer to Figure 12B-40.

INSTALL RETRACTABLE STARTER

1. Install the retractable starter and hex cap screws. Leave the screws slightly loose.
2. Pull the starter handle out 8-10" until the pawls engage in the drive cup. Hold the handle in this position and tighten screws securely.

INSTALL FUEL PUMP

1. Install the gasket, fuel pump, plain washers, and fillister head screws. Refer to Figure 12B-43.

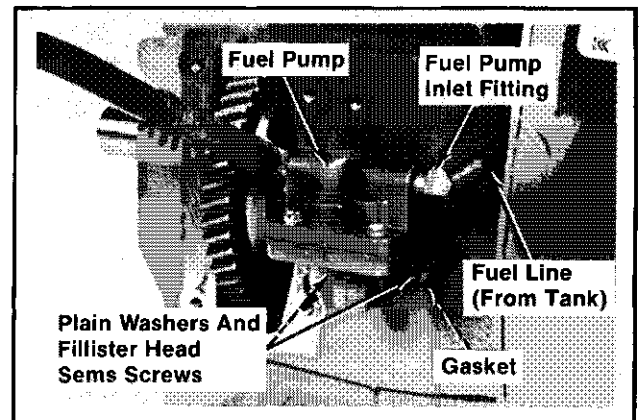

Figure 12B-43. Installing Fuel Pump.

CAUTION: Make sure the fuel pump lever is positioned above the camshaft. Damage to the fuel pump, and subsequent severe engine damage could result if the lever is positioned below the camshaft. Refer to Figure 12B-44.

Torque the screws to **40/45 in lb.**

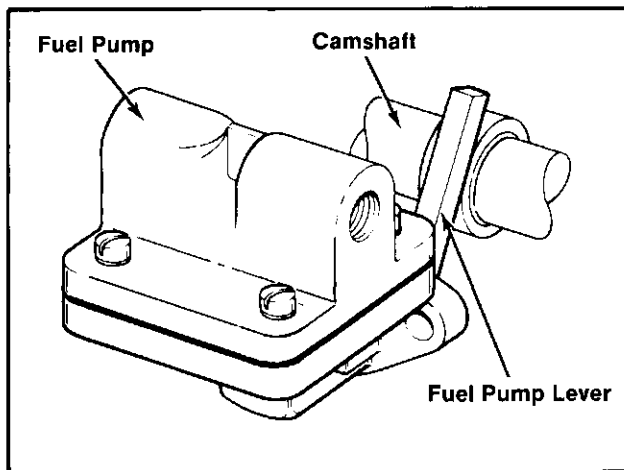

Figure 12B-44. Installing Fuel Pump.

2. Connect the fuel line to fuel pump inlet fitting.

INSTALL BREATHER ASSEMBLY

1. Install the stud, gasket, breather plate, reed, reed stop, seal, and filter. Refer to Figure 12B-45.

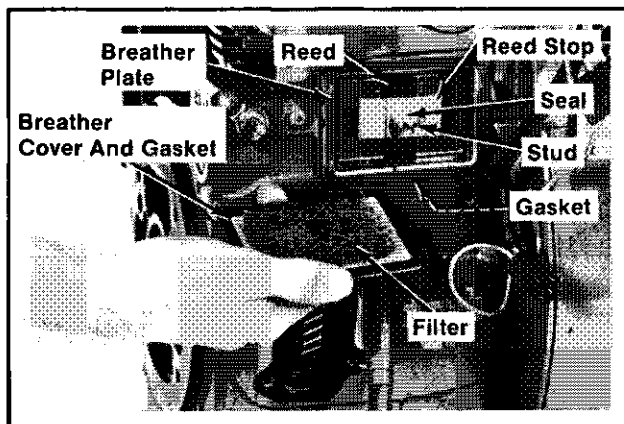

Figure 12B-45. Installing Breather Components.

2. Install the gasket, breather cover, and palnut.

INSTALL EXTERNAL GOVERNOR COMPONENTS, AND THROTTLE AND CHOKE CONTROLS

1. Install the long leg of governor spring to throttle control lever. Refer to Figure 12B-46.

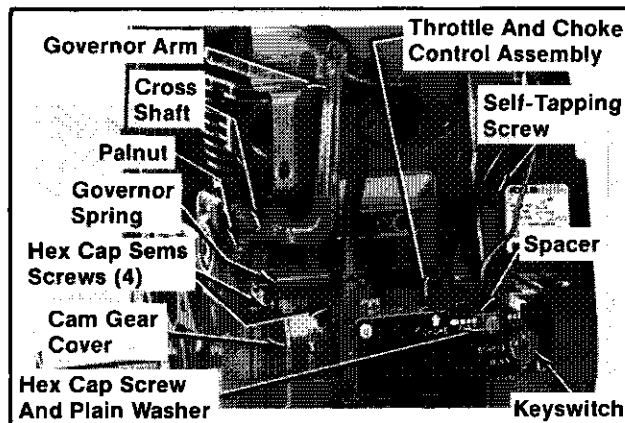

Figure 12B-46. Installing External Governor Components, And Throttle And Choke Controls.

2. Install the gasket, throttle and choke control assembly, gasket, cam gear cover, plain washer, hex cap sems screws, and self-tapping screw. Torque cam gear cover screws to **115 in. lb.** Install the spacer, plain washer, and hex cap screw.
3. Install the connector/wiring harness to back of keyswitch.
4. Install the governor spring to the governor arm. Install the governor arm to the cross shaft. Leave the palnut slightly loose as the governor arm and cross shaft will be adjusted after the carburetor and throttle linkage are installed.

INSTALL CARBURETOR, THROTTLE LINKAGE, AND CHOKE LINKAGE

1. Install the fuel line and hose clamps. Refer to Figure 12B-47.

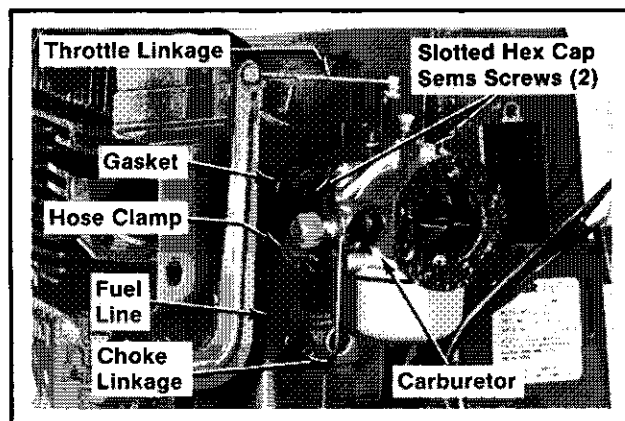

Figure 12B-47. Installing Carburetor, Throttle Linkage, And Choke Linkage.

2. Install the gasket, carburetor, and slotted hex cap sems screws.
3. Install the throttle linkage into the nylon inserts in the governor arm and carburetor throttle lever.
4. Adjust the governor as instructed below.
5. Install the choke linkage to the carburetor choke lever, and then into the nylon insert in the choke control lever.

Governor Adjustment

The governor cross shaft/governor arm must be adjusted every time the governor arm is loosened or removed from cross shaft.

1. Pull the governor arm away from the carburetor as far as it will go. Refer to Figure 12B-48.

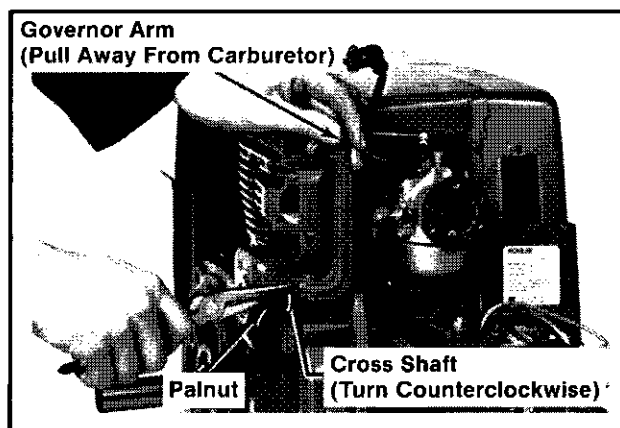

Figure 12B-48. Adjusting Governor Arm/Cross Shaft.

2. Grasp end of cross shaft with pliers and turn counterclockwise as far as it will go.
3. Torque the palnut on governor arm to **15 in. lb.**

NOTE: Make sure there is at least $1/16''$ clearance between the governor arm and the upper-left cam gear cover fastener to prevent interference. Refer to Figure 12B-49.

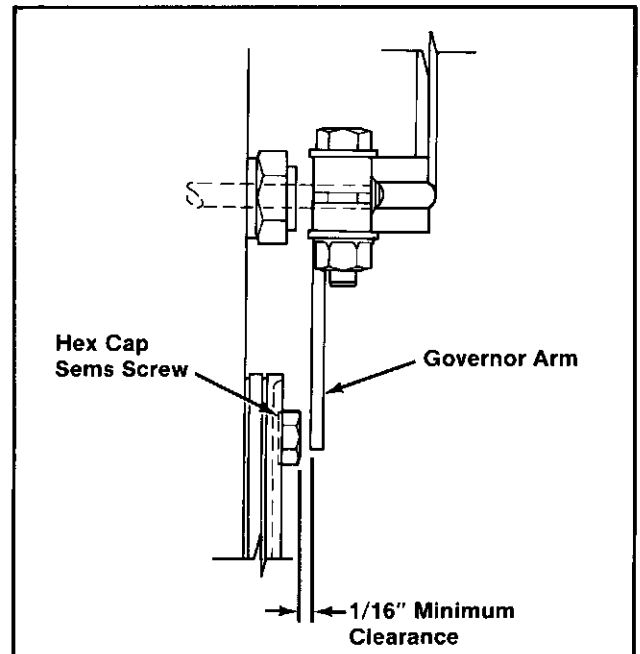

Figure 12B-49. Governor Arm Clearance.

INSTALL RECTIFIER-REGULATOR

1. Insert the B+ lead into the center position of connector. Install the stator leads/connector to the rectifier-regulator. Refer to Figure 12B-50.

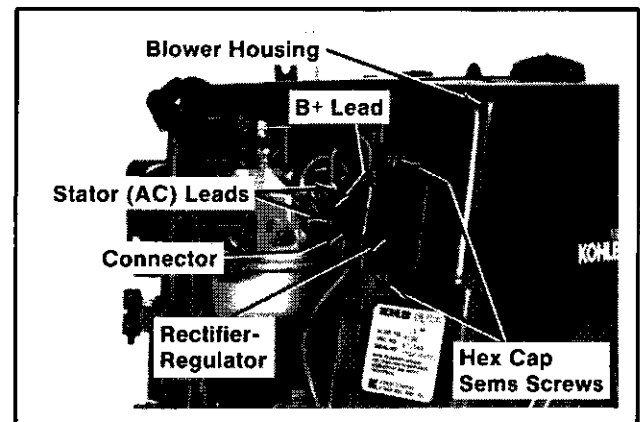

Figure 12B-50. Installing Rectifier-Regulator.

2. Install the rectifier-regulator and hex cap sems screws.

INSTALL MUFFLER

1. Install the threaded exhaust pipe and muffler.

INSTALL AIR CLEANER

1. Install the breather hose, gasket, air cleaner base, and screws. Refer to Figure 12B-51.

CAUTION: Make sure that the breather hose seals tightly in the air cleaner base and the breather cover to prevent unfiltered air from entering the engine.

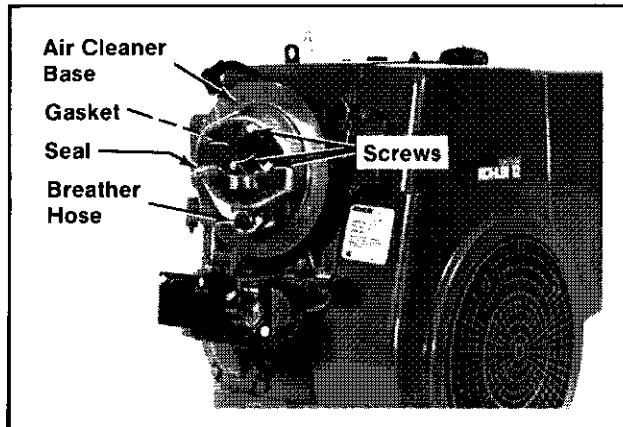

Figure 12B-51. Installing Air Cleaner Base.

2. Install the seal, paper element, element cover, and element cover nut. Torque the nut to **50 in. lb.** Refer to Figures 12B-51 and 12B-52.

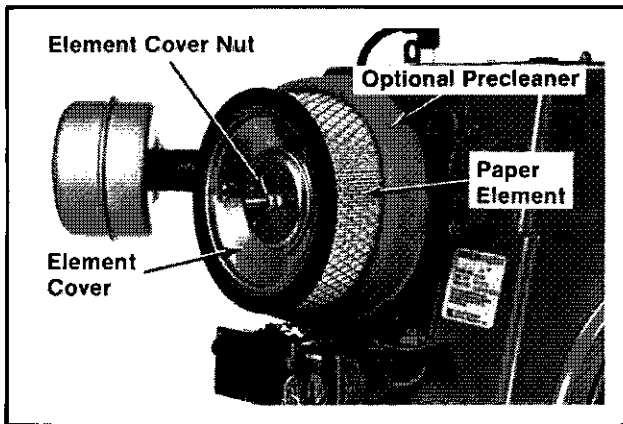

Figure 12B-52. Installing Air Cleaner Element.

3. If equipped, install the optional foam precleaner (cleaned and oiled) over the paper element.
4. Install the air cleaner cover and wing nut. Tighten the wing nut until it is snug. Do not overtighten. Refer to Figure 12B-53.

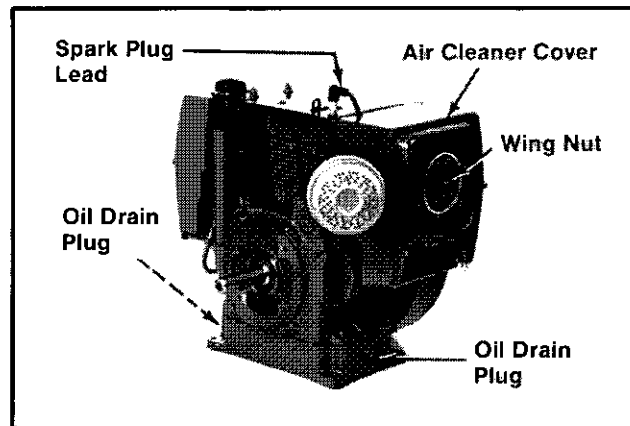

Figure 12B-53. Installing Air Cleaner Cover, Oil Drain Plug, And Spark Plug Lead.

PREPARE THE ENGINE FOR OPERATION

The engine is now completely reassembled. Before operating the engine, be sure to do the following:

- Make sure all hardware is tightened securely and oil drain plugs are installed.
- Fill the crankcase with the correct amount, weight, and type of oil. Refer to the oil recommendations and procedures in the "General Information" and "Periodic Maintenance" sections.
- Fill the fuel tank with the proper type of gasoline and open fuel shut-off valve (if equipped). Refer to the fuel recommendations in the "General Information" section.
- Adjust the carburetor main fuel needle, idle fuel needle, or idle speed adjusting screw as necessary. Refer to the "Fuel System And Governor" section.
- Make sure the maximum engine speed does not exceed 3600 RPM. Adjust the high speed stop as necessary. Refer to the "Fuel System And Governor" section.